

 MITSUBISHI MATERIALS

SOLID MILLING TOOLS



DIA  **EDGE**

NEW

MITSUBISHI MATERIALS

INTRODUCING THE NEW GENERAL CATALOGUE C009 – 2022/2023

TARGETED, COMPACT, HANDY.

Mitsubishi Materials' wide product portfolio is now shown in catalogues that represent individual application areas, offering users fast and easy access to targeted product information.

There is now a set of catalogues in small, practical sizes comprised of the following five volumes:

- **TURNING TOOLS**
- **DRILLING TOOLS**
- **SOLID MILLING TOOLS**
- **INDEXABLE MILLING TOOLS**
- **MPLUS**

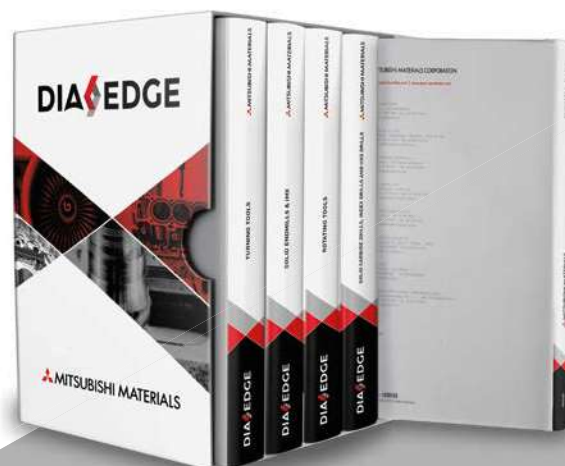

NEW DESIGN

EASY HANDLING

HIGHER FLEXIBILITY

INDIVIDUAL APPLICATION AREAS

The slipcase provided enables easy storage and offers the required space for all future catalogues, including the product news brochures that will be published within the 2-year life cycle of the catalogue. Each new product news brochure published within the 2-year cycle will completely replace the previous version. Therefore, please dispose of old versions when new ones are supplied to ensure that the collection is up to date.

NOTES:

- With this publication, all previous general catalogues and product news brochures lose their validity.
- The product news catalogues are released twice a year, in April and October.
- The new general catalogue can be ordered only as a set of five. **Order number: C009E**



DIGITAL VERSION

For the digital version of the catalogue, please scan the QR code or visit us at www.mhg-mediastore.net

SOLID MILLING TOOLS



INNOVATION – THE KEY TO CONTINUOUS GROWTH

Mitsubishi's wide range of milling products provides off the shelf or tailor-made solutions, whether for the automotive, aerospace and medical or general machining industries.

From the smallest cutter in the mini end mill series to the ceramic CE-series, Mitsubishi Materials provides targeted, innovative, high quality products.

DIA EDGE

CREATE A BETTER FUTURE TOGETHER WITH OUR CUSTOMERS

Announcing DIAEDGE, our new brand of tools that brings together cutting-edge technologies, exciting all who use them.

The aim is not only to offer value with our tools, but to think together with customers, share inspiration and continue to take on new challenges.



 **MITSUBISHI MATERIALS**

INDEX

SOLID MILLING TOOLS

SOLID END MILLS	I001
EXCHANGEABLE HEAD END MILLS	J001
TECHNICAL DATA	P001
INDEX	1
GENERAL INFORMATION	



HOW TO READ THE STANDARD OF SOLID END MILLS

●How this section page is organised

① Organised according to cutting mode for milling. (Refer to END MILL LIST.)

CUTTING EDGE GEOMETRY

PHOTO OF PRODUCT

ITEM NUMBER

PRODUCT TITLE

PRODUCT BLOCK

PRODUCT INFORMATION ICONS

GEOMETRY

PRODUCT FEATURES

ROUGHING **BARREL** **TAPER** **RADIUS** **BALL** **SQUARE**

MSTAR END MILLS
MS2SS
 End mill, Short cut length, 2 flute

Material: Carbide (G20902) | Hardened Steel (G20902) | Hardened Steel (P20902) | Austenitic Stainless Steel (G20902) | Titanium Alloy (Metal Package) (G20902) | Copper Alloy (G20902) | Aluminum Alloy (G20902)

DCON: 1, 2, 3, 4, 5, 6, 7, 8, 9, 10, 11, 12
 APMX: 0.1, 0.2, 0.3, 0.4, 0.5, 0.6, 0.7, 0.8, 0.9, 1.0, 1.5, 2.0, 2.5, 3.0, 4.0, 5.0, 6.0, 7.0, 8.0, 9.0, 10.0, 11.0, 12.0
 LF: 40, 45, 50, 55, 60, 65, 70, 75, 80, 85, 90, 95, 100, 105, 110, 115, 120

2 flute end mill for general use.

Order Number	DC	APMX	LF	DCON	Flutes	Stock	Type
MS2SSD0010	0.1	0.15	40	4	2	●	1
MS2SSD0020	0.2	0.3	40	4	2	●	2
MS2SSD0030	0.3	0.45	40	4	2	●	2
MS2SSD0040	0.4	0.6	40	4	2	●	2
MS2SSD0050	0.5	0.75	40	4	2	●	2
MS2SSD0060	0.6	0.9	40	4	2	●	2
MS2SSD0070	0.7	1.1	40	4	2	●	2
MS2SSD0080	0.8	1.2	40	4	2	●	2
MS2SSD0090	0.9	1.4	40	4	2	●	2
MS2SSD0100	1	1.5	40	4	2	●	2
MS2SSD0120	1.2	1.8	40	4	2	●	2
MS2SSD0150	1.5	2.3	40	4	2	●	2
MS2SSD0180	1.8	2.7	40	4	2	●	2
MS2SSD0200	2	3	40	4	2	●	2
MS2SSD0250	2.5	3.8	40	4	2	●	2
MS2SSD0300	3	4.5	45	6	2	●	2
MS2SSD0400	4	6	50	6	2	●	2
MS2SSD0500	5	7.5	50	6	2	●	2
MS2SSD0600	6	9	50	6	2	●	3
MS2SSD0700	7	10.5	60	8	2	●	2
MS2SSD0800	8	12	60	8	2	●	3
MS2SSD0900	9	13.5	70	10	2	●	2
MS2SSD1000	10	15	70	10	2	●	3
MS2SSD1100	11	16.5	75	12	2	●	2
MS2SSD1200	12	18	75	12	2	●	3

1036 ● - Inventory maintained, * - Inventory maintained in Japan.

LEGEND FOR STOCK STATUS MARK
 is shown on the left hand page of each double-page spread.

PRODUCT STANDARDS
 indicates order numbers, dimensions, and stock status.

ROTATING TOOLS

SOLID END MILLS

PRODUCT CODE DESCRIPTIONS	I002
SYMBOL DESCRIPTIONS	I003
COATING TECHNOLOGY.....	I004
TOOL NAVI	I006
END MILL SELECTION CHART	I026

SOLID END MILLS STANDARD

MSTAR END MILLS.....	I036
MS PLUS END MILLS.....	I079
IMPACT MIRACLE END MILLS	I125
IMPACT MIRACLE REVOLUTION END MILLS	I163
VQ END MILLS	I191
CERAMIC END MILLS.....	I242
CRN COATED END MILLS.....	I244
ALIMASTER END MILLS.....	I258
DLC COATED END MILLS.....	I278
DIAMOND COATED END MILLS	I280
VIOLET END MILLS.....	I292

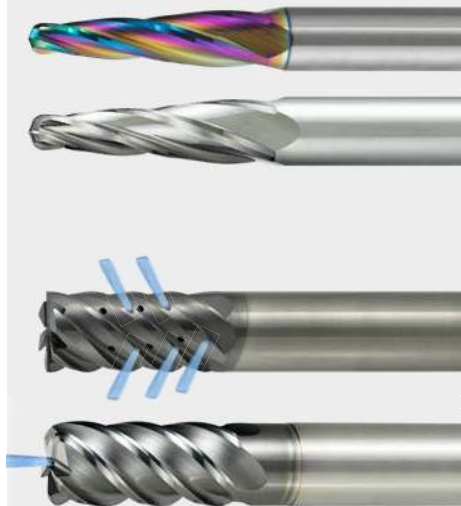

*Alphabetical order index

NEW I275 A3SA	I085 MP2XLB	I135 VF3XB	NEW I193 VQN4MBF
NEW I276 A3SARB	I093 MP3XB	I125 VF4MB	I239 VQSVR
I258 AM2MB	I106 MPJHV	I142 VF4MV	I232 VQT5MVRB
I260 AM2MR	I103 MPMHV	I177 VF6MHV	I236 VQT6UR
I259 AM2SC	I101 MPMHV/W	I180 VF6MHVRB	I216 VQXL
I264 AM2SCRB	I117 MPMHVRB	I190 VF6SVRCH	
I262 AM3MF	I099 MPSHV/W	I179 VF8MHVCH	
I261 AM3SS	I120 MPXLRB	I184 VF8MHVRBCH	
I267 AM3SSRB	I055 MS2ES	I148 VFFDRB	
I263 AM4MF	I040 MS2JS	I153 VFHV RB	
I271 AMMR	I042 MS2LS	I146 VFMD	
I269 AMSR	I071 MS2MRB	I151 VFMDRB	
I273 C4LATB	I037 MS2MS	I188 VFMFPR	
I242 CE4SRB	I036 MS2SS	I178 VFMHVCH	
I242 CE6SRB	I060 MS2XL	I182 VFMHVRBCH	
I244 CRN2MB	I064 MS2XL6	I164 VFR2SB	
I254 CRN2MRB	I056 MS3ES	I166 VFR2SBF	
I249 CRN2MS	I058 MS4EC	I163 VFR2SSB	
I252 CRN2XL	I049 MS4JC	NEW I168 VFR2XLB	
I246 CRN2XLB	I047 MS4MC	NEW I171 VFRPSRB	
I256 CRN2XLRB	I074 MS4MRB	I145 VFSD	
I251 CRN4JC	I046 MS4SC	I150 VFSDRB	
I291 DC2SB	I067 MS4XL	I186 VFSFPR	
I293 DC2XLB	I077 MS6MH-E	I189 VFSFPRCH	
I285 DF2XLB	I077 MS8MH-E	NEW I199 VQ2XLB	
I288 DF2XLBFB	I052 MSMHD	NEW I194 VQ4SVB	
I290 DF4JC	I044 MSMHZD	NEW I196 VQ4WB	
I283 DFC4JC	I051 MSSHD	I219 VQ6MHVCH	
I284 DFCJRT	I296 VA2MS	I230 VQ6MHVRBCH	
NEW I280 DLC3SA	I295 VA2SS	NEW I234 VQFDRB	
NEW I281 DLC3SARB	I298 VA4MC	NEW I228 VQHVRB	
NEW I278 DLC4LATB	I302 VAMFPR	NEW I214 VQJHV	
NEW I108 MP2ES	I304 VAMR	I210 VQMHV	
NEW I111 MP3ES	I300 VASFPR	I221 VQMHV RB	
NEW I114 MP4EC	I140 VF2MV	I226 VQMHV RBFB	
NEW I081 MP2MB	I176 VF2WB	I201 VQMHZV	
NEW I080 MP2SB	I143 VF2XL	I207 VQMHZVOH	
NEW I083 MP2SDB	I129 VF2XLB	NEW I191 VQN2MB	
NEW I079 MP2SSB	I127 VF2XLB S	NEW I192 VQN4MB	

PRODUCT CODE DESCRIPTIONS

PRODUCT CODE OF END MILLS



SOLID END MILLS

End mill names	Number of flutes	Flute length	Features	Dimensions	Others
VQ : SMART MIRACLE end mills	1 : 1flute	ES : Extra short	S : General-use	D**** : Diameter	S** : Shank diameter
VQN : focussed on machining Ni-based alloys	2 : 2flute	S : Short	A : For light alloy	ex.	ex.
VQT : focussed on machining Ti-alloys	3 : 3flute	M : Medium	C : Centre cut	D0050 → φ0.5	S03 → φ3
VFR : IMPACT MIRACLE REVOLUTION end mills	4 : 4flute	J : Semi long	D : Strong Edge	D0500 → φ5	S04 → φ4
VF : Impact Miracle end mills	5 : 5flute	L : Long	B : Ball nose	R**** : Radius of ball nose	S05 → φ5
MP : MS Plus end mills	6 : 6flute	XL : Long neck	R : Roughing	ex.	S06 → φ6
MS : Mstar end mills	8 : 8flute	X : Taper neck	F : Finishing	R0050 → R0.5	S10 → φ10
CRN : CRN coated end mills	...		H : High helix	R0500 → R5	S12 → φ12
DLC : DLC coated end mills			TB : Taper ball nose		N*** : Neck length
DFC : CVD diamond coated end mills			RB : Corner radius		T**** : Taper angle one side
DF : Diamond coated end mills			FPR : Fine pitch roughing		L** : Flute length
CE : Ceramic end mills			V : Irregular spiral helix angle		A*** : Overall length
AM : ALIMASTER end mills			CH : Coolant holes (Side)		***W : Weldon
C : uncoated carbide			WB : Wide ball nose		**C : Coolant holes (Centre)
VA : Violet end mills			UR : Multi step radius		
			Z : Drilling		
			OH : Coolant holes (End)		

*Other types are available by special order.

SYMBOL DESCRIPTIONS

Tool material



Ultra micro grain carbide

Ultra micro grain carbide is used as the substrate material.



Cubic boron nitride

Mitsubishi's original CBN is used.



Ceramic

Ceramic is used as the substrate material.



High hardness powder metallurgy HSS

High hardness powder metallurgy HSS is used as the substrate material.

Tolerances



Outside diameter tolerance

Indicates the diameter tolerance of the end mill.



R tolerance

Indicates the radial tolerance of a ball nose end mill.



R tolerance

Indicates the radial tolerance of an end mill with a corner radius.



Tolerance of Taper angle

Indicates the tolerance of the taper angle.



Tolerance of Point diameter

Indicates the tolerance of the point diameter.



Shank diameter tolerance

Indicates the shank diameter tolerance.

Angle, coolant hole, sharp corner edge and gash land



Helix angle

Indicates the helix angle of the end mill.



End cutting edge with coolant hole



Peripheral cutting edge with coolant hole



Sharp corner edge

Indicates the end mill has a sharp corner edge.



Gash land

Indicates the end mill cutting edge with protection chamfer.

Coating



SMART MIRACLE Coating

(Al, Cr)N coating optimum for stainless and difficult-to-cut materials.



VQT Coating

(Al, Cr)N coating optimum for Ti-alloys



VQN Coating

(Al, Ti, Si)N coating optimum for Ni-based alloys



VFR Coating

The (Al, Cr, Si)N / (Al, Ti, Si)n PVD multilayer Coating is ideal for machining extremely hard steels up to 70HRC.



IMPACT MIRACLE Coating

Single phase nano crystal coating technology for higher film hardness and heat resistance.



(Al, Ti, Cr)N multilayer coating

Higher versatility, for drilling carbon steel, alloy steel and hardened steel.



(Al, Ti)N Coating

(Al, Ti)N offers higher versatility.



CRN Coating

Newly developed CrN coating for Copper Electrodes machining.



DLC Coating

Hardness similar to that of CVD diamond coating achieved with high adhesion strength.



CVD Diamond Coating

Suitable for CFRP and CFRP-Aluminium materials.



CVD Diamond Coating

High performance coating for hard brittle materials excelling in film adhesion to the substrate.



Diamond Coating

Suitable for graphite machining.



Violet Coating

The original Miracle (Al, Ti)N coating achieves longer tool life.

Work application range

The recommendations for work materials in the TOOL NAVI section are demonstrated as follows:

The upper line shows the first recommendations.

The lower line shows the second recommendations.

1st Recommendation



2nd Recommendation



COATING TECHNOLOGY

VFR **IMPACT MIRACLE REVOLUTION Coating**

The combination of the (Al, Cr, Si) N coating (newly-developed), which has a high oxidation temperature and high lubricity, together with the (Al, Ti, Si) N coating, which has better wear resistance and high adhesion, allows reliable hardened steel machining.

SOLID END MILLS



VF **IMPACT MIRACLE Coating**

Faster cutting speeds and longer tool life for high hardness materials and heat resistant alloys.

In comparison with conventional coatings, single-phase nano crystal coating technology offers higher coating hardness and heat resistance. When machining hardened steels IMPACT MIRACLE coating offers a lower coefficient of friction and helps prevent abnormal damage such as chipping.



FEATURES OF IMPACT MIRACLE COATING

	IMPACT MIRACLE Single phase nano coating (Al,Ti,Si)N	(Al,Ti,Si)N	(Al,Ti)N
Hardness (HV)	3700	3200	2800
Oxidation Temperature (°C)	1300	1100	840
Adhesion (N) ¹⁾	100	80	80
Wear Coefficient ²⁾ (800°C)	0.48	0.53	0.58

1) Adhesion : Measured by critical load scratch test.
2) Coefficient of friction : Measured by ball-on-disk method.
(Counter gear : VW-nr. 1.2379(D2) 60HRC)

MS+ **(Al,Ti,Cr)N multilayer coating (MS Plus)**

MS plus provides long tool life on materials up to 52 HRC.

Greatly improved wear resistance even when machining hardened materials.

Properties of (Al,Ti,Cr)N multilayer coating (MS Plus)

	(Al,Ti,Cr)N multilayer	(Al,Ti)N	(Al,Cr)N
Hardness (HV)	3200	2800	3100
Oxidation Temperature (°C)	1100	800	1100
Adhesion (N)	100	80	80

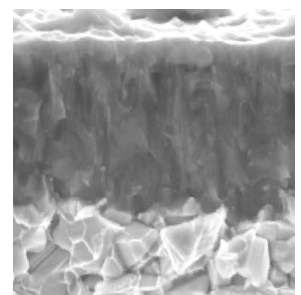

VQ Coating

These end mills have been treated with a newly developed (Al, Cr)N group coating which delivers substantially better wear resistance. The surface of the coating has been given a smoothening treatment resulting in better machined surfaces, reduced cutting resistance and improved chip discharge. This is the next generation of coated end mills that delivers long tool life when machining stainless steel and other difficult-to-cut materials.

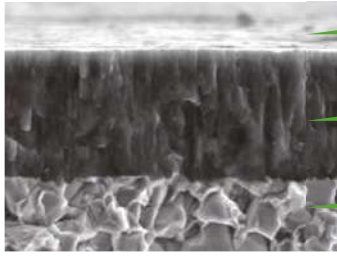

Smoothed surface "ZERO- μ Surface"

Newly developed (Al, Cr)N group coating

Super-fine-particle, super-hard base material



SMART MIRACLE coating

ZERO- μ Surface

With the unique ZERO- μ Surface, the cutting edge retains its sharpness. While previous technologies often resulted in diminished sharpness, the ZERO- μ Surface achieves both smoothness and sharpness, as well as longer tool life.



SOLID END MILLS

CRN Coating

Specially designed for milling copper electrodes and copper alloys.

CRN coating has been developed for copper alloy milling. It has superior wear resistance and excellent adhesion strength by using Miracle coating technology. The excellent anti adhesion properties needed for copper machining has been achieved due to its low coefficient of friction at high temperatures.

DLC Coating

For milling of aluminium alloys at high speed.

Hardness similar to that of CVD diamond coating achieved but with high adhesion strength.

Mitsubishi Materials and NAGATA SEIKI have jointly developed a unique DLC coating that has substantially increased "adhesion strength" compared to previous DLC coatings.

Diamond Coating

Proprietary CVD diamond coating produces excellent wear resistance and smooth hole surface.

The newly developed CVD diamond coated carbide material achieves outstanding abrasion resistance and smoothness due to a proprietary fine multilayer diamond crystal control technology.

Diamond Coating

Diamond coating for graphite and non-ferrous materials.

Owing to Mitsubishi's unique plasma chemical vapor deposition (CVD) coating technology, the diamond coating is affixed firmly to the substrate to ensure long tool life and prevent peeling. DF end mill series suitable for graphite machining.

VIOLET Coating

(Al,Ti)N coating, excellent adhesion strength for HSS tools.

Violet coating is the name of the technology of successfully that can apply a Miracle type coating to HSS substrate tools. Mitsubishi's unique technology of applying (Al,Ti)N coating at the low temperatures required for HSS substrates, means that Violet coating has the same level of adhesion strength as Miracle coating. Additionally, high film hardness and excellent oxidation resistance properties have also been realised.

TOOL NAVI

HOW TO USE TOOL NAVI

3 steps to find the correct tool and cutting data.

STEP1 Chose work material, end mill type and cutting length

SOLID END MILLS

INDEX

Work material	Carbon steel Alloy steel Cast iron	P	Square end mills	
			Short flute	1008
			Medium flute	1009
			Semi long	1010
			Long neck	1010
	Corner radius end mills			
	Short / Medium flute	1011		
	Long neck / Taper neck	1012		
	Ball nose end mills			
	Short / Medium flute	1012		
Long neck	1013			
Taper neck	1013			
Hardened steel	H	Square end mills		
		Medium flute	1014	
		Long neck	1014	

End mill type
Page

STEP2 Chose end mill

SOLID END MILLS TOOL NAVI

Product Name	Coating or Substrate	End Mills	Size Range	APMX	LU LxDC	Flutes	Finish / Rough	Work Materials Upper : 1st Recommendation Lower : 2nd Recommendation	Page
P									
Square end mills									
Short flute (APMX-1.5xDC)									
MPSHV/W			DC Ø=20	1.5xDC	2.5xDC	4	F R	P M H S N	1099
MS2ES			DC 3-12	0.5 -1xDC	-	2	F R	P H M S N	1055
MP2ES			DC 3-10	1.5xDC	-	2	F R	P H M S N	1108
MS2SS			DC 0.1-12	1.5xDC	-	2	F R	P H M S N	1036

Recommend

*1 **F**
R

*1 Finish
*2 Rough

1st Recommendation
2nd Recommendation
Page

STEP3 Chose size and cutting condition

End mill size

MPSHV/W

End mill, Short cut length, 2.5 x DC neck recess

Order Number	DC	APMX	LU	DN	LF	DCDN	Flute	Type
MPSHV02000010	6	9	15	5.85	50	6	4	1
MPSHV02000015	8	12	20	7.85	60	8	4	1
MPSHV02000020	10	15	25	9.7	70	10	4	1
MPSHV02000025	12	18	30	11.7	80	12	4	1
MPSHV02000030	15	24	40	15.0	90	15	4	1
MPSHV02000040	20	30	50	19.5	110	20	4	1
MPSHV02000050	25	36	60	23.5	130	25	4	1

1099

Cutting conditions

MS PLUS END MILLS MPSHV/W

End mill, Short cut length, 2.5 x DC neck recess

RECOMMENDED CUTTING CONDITIONS

Side milling — High speed cutting conditions (HSC)

Work Material	DC	APMX	LU	DN	LF	DCDN	Flute	Type
1000	6	9	15	5.85	50	6	4	1
1000	8	12	20	7.85	60	8	4	1
1000	10	15	25	9.7	70	10	4	1
1000	12	18	30	11.7	80	12	4	1
1000	15	24	40	15.0	90	15	4	1
1000	20	30	50	19.5	110	20	4	1
1000	25	36	60	23.5	130	25	4	1

Side milling — High depth of cut conditions (HPC)

Work Material	DC	APMX	LU	DN	LF	DCDN	Flute	Type
1000	6	9	15	5.85	50	6	4	1
1000	8	12	20	7.85	60	8	4	1
1000	10	15	25	9.7	70	10	4	1
1000	12	18	30	11.7	80	12	4	1
1000	15	24	40	15.0	90	15	4	1
1000	20	30	50	19.5	110	20	4	1
1000	25	36	60	23.5	130	25	4	1

Slotted

Work Material	DC	APMX	LU	DN	LF	DCDN	Flute	Type
1000	6	9	15	5.85	50	6	4	1
1000	8	12	20	7.85	60	8	4	1
1000	10	15	25	9.7	70	10	4	1
1000	12	18	30	11.7	80	12	4	1
1000	15	24	40	15.0	90	15	4	1
1000	20	30	50	19.5	110	20	4	1
1000	25	36	60	23.5	130	25	4	1



















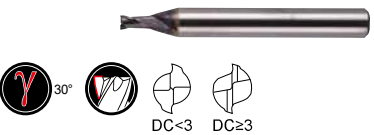







1100

INDEX

Carbon steel Alloy steel Cast iron	P	Square end mills Short flute I008 Medium flute I009 Semi long I010 Long neck I010 Corner radius end mills Short / Medium flute I011 Long neck / Taper neck I012 Ball nose end mills Short / Medium flute I012 Long neck I013 Taper neck I013
Hardened steel	H	Square end mills Medium flute I014 Long neck I014 Corner radius end mills Short / Medium flute I014 Long neck / Taper neck I015 Ball nose end mills Short / Medium flute I015 Long neck / Taper neck I016
Austenitic stainless steel	M	Square end mills Medium flute I017 Semi long I018 Long neck I018
Ti alloy Heat resistant alloys	S	Corner radius end mills Short / Medium flute I019 Ball nose end mills Short / Medium flute I020 Long neck I020 Barrel end mills Medium flute I020
Ni alloy Heat resistant alloys	S	Ceramic radius end mills Short flute I021
Copper alloy Aluminium alloy	N	Square end mills Short flute I022 Medium flute I022 Semi long I023 Long neck I023 Corner radius end mills Short / Medium flute I023 Long neck I023 Ball nose end mills Short / Medium flute I024 Long neck I024 Tapered flute I024
Graphite FRP	X	Square end mills Semi long I025 Ball nose end mills Long neck I025













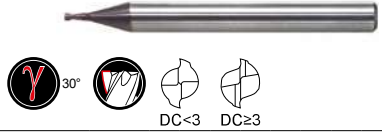















TOOL NAVI

SOLID END MILLS

Product Name	Coating or Substrate	End Mills	Size Range	APMX	LU LxDC	Flutes	Finish / Rough	Work Materials Upper : 1st Recommendation Lower : 2nd Recommendation	Page
P									
Square end mills									
Short flute (APMX=1.5xDC)									
MPSHV/W	MS ^s		DC 6-20	1.5xDC	2.5xDC	4	F  R 	P M H S N	I099
MS2ES	MS		DC 3-12	0.5 -1xDC	-	2	F  R 	P H M S N	I055
NEW MP2ES	MS ^s		DC 3-10	1.5xDC	-	2	F  R 	P H M S N	I108
MS2SS	MS		DC 0.1-12	1.5xDC	-	2	F  R 	P H M S N	I036
MS3ES	MS		DC 3-12	0.5 -1xDC	-	3	F  R 	P H M S N	I056
NEW MP3ES	MS ^s		DC3-12	1.3 -1.5xDC	-	3	F  R 	P H M S N	I111
MS4EC	MS		DC 3-14	0.5 -1xDC	-	4	F  R 	P H M S N	I058
NEW MP4EC	MS ^s		DC3-14	1 -1.5xDC	-	4	F  R 	P H M S N	I114
MS4SC	MS		DC 1-12	1.5xDC	-	4	F  R 	P H M S N	I046



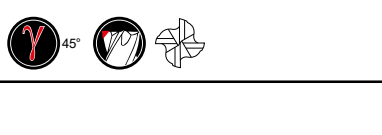



















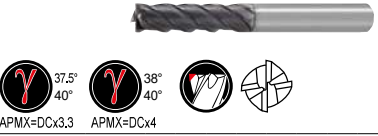

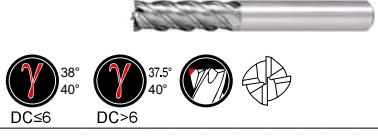
* APMX : Depth of Cut
* DC : Cutting Diameter

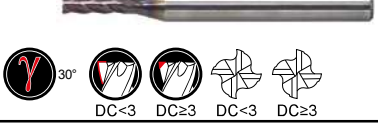

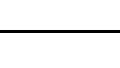
Product Name	Coating or Substrate	End Mills	Size Range	APMX	LU LxDC	Flutes	Finish / Rough	Work Materials Upper : 1st Recommendation Lower : 2nd Recommendation	Page
MSSHD	MS		DC 3-20	1.5xDC	-	4	F  R 	P H M S N	I051
Medium flute (APMX-3xDC)									
MS2MS	MS		DC 0.2-20	2xDC	-	2	F  R 	P H M S N	I037
MS2JS	MS		DC 0.1-12	3xDC	-	2	F  R 	P H M S N	I040
MPMHV/W	MS+		DC 6-20	2xDC	2.5xDC	4	F  R 	P M H S N	I101
MPMHV	MS+		DC 1-22	2.5xDC	-	4	F  R 	P M H S N	I103
VQMHZV	VQ		DC 1-20	1.6 -2.5xDC	-	3	F  R 	P M S N	I201
VQMHZVOH	VQ		DC 6-16	1.9 -2.4xDC	-	3	F  R 	P M S N	I207
MSMHZD	MS		DC 1-20	1.6 -2.5xDC	-	3	F  R 	P H M S N	I044
VQMHV	VQ		DC 1-25	2 -2.8xDC	-	4	F  R 	P M S N	I210
MSMHD	MS		DC 2-25	2 -3.1xDC	-	4	F  R 	P H M S N	I052



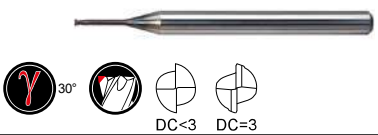



TOOL NAVI

SOLID END MILLS

Product Name	Coating or Substrate	End Mills	Size Range	APMX	LU LxDC	Flutes	Finish / Rough	Work Materials Upper : 1st Recommendation Lower :	Page
P									
Square end mills									
Medium flute (APMX-3xDC)									
MS6MH-E	MS		DC 6-16	2 -2.4xDC	-	6	F  R 	P H M S N	I077
MS8MH-E	MS		DC20	1.8xDC	-	8	F  R 	P H M S N	I077
VQSVR	VQ		DC 3-20	1.8 -2.4xDC	-	3 4	F  R 	P M S N	I239
Semi long (APMX-4xDC)									
MS2LS	MS		DC 0.2-12	4xDC	-	2	F  R 	P H M S N	I042
MPJHV	MS		DC 1-20	3.3 -4xDC	-	4	F  R 	P M H S N	I106
VQJHV	VQ		DC 1-20	3.3 -4xDC	-	4	F  R 	P M S N	I214
MS4JC	MS		DC 1-12	4xDC	-	4	F  R 	P H M S N	I049
Long neck (LU-30xDC)									
VQXL	VQ		DC 0.2-1.0	1.4 -1.67xDC	2.5 -6xDC	3 4	F  R 	P M S N	I216
VF2XL	VF		DC 0.2-3	1.5 -1.7xDC	2.5 -12xDC	2	F  R 	P H	I143

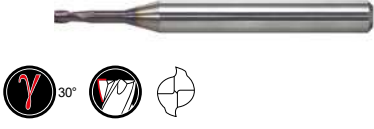

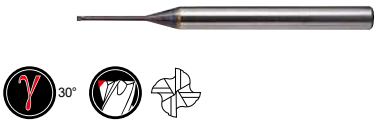







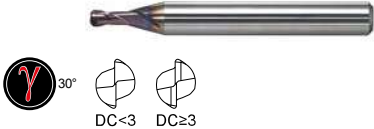







* APMX : Depth of Cut
* DC : Cutting Diameter



Product Name	Coating or Substrate	End Mills	Size Range	APMX	LU LxDC	Flutes	Finish / Rough	Work Materials Upper : 1st Recommendation Lower : 2nd Recommendation	Page
MS2XL	MS	 DC < 0.4 DC ≥ 0.4	DC 0.2–6	1.3 –1.6xDC	2.5 –30xDC	2	F  R 	P H M S N	I060
MS2XL6	MS	 DC < 0.4 DC ≥ 0.4	DC 0.3–2.5	1.5 –2.7xDC	2.5 –5xDC	2	F  R 	P H M S N	I064
MS4XL	MS	 DC < 0.4 DC ≥ 0.4	DC 1–10	1xDC	2.7 –16xDC	4	F  R 	P H M S N	I067

Corner radius end mills

Short / Medium flute (APMX–2.8xDC)

MS2MRB	MS	 DC < 3 DC ≥ 3	DC 1–12	2xDC	–	2	F  R 	P H M S N	I071
MPMHVRB	MS	 DC < 3 DC ≥ 3	DC 1–20	2.5xDC	–	4	F  R 	P M H S N	I117
VQMHVRB	VQ	 DC < 3 DC ≥ 3	DC 2–20	2 –2.8xDC	–	4	F  R 	P M S N	I221
VQMHVRBF	VQ	 DC < 3 DC ≥ 3	DC 6–16	2.2 –2.4xDC	–	4	F  R 	P M S N	I226
MS4MRB	MS	 DC < 3 DC ≥ 3	DC 3–20	1.9 –2.8xDC	–	4	F  R 	P H M S N	I074
VFHVRB	VF	 DC < 3 DC ≥ 3	DC 1–16	1 –1.6xDC	–	4	F  R 	P H M S	I153

TOOL NAVI











SOLID END MILLS

Product Name	Coating or Substrate	End Mills	Size Range	APMX	LU LxDC	Flutes	Finish / Rough	Work Materials Upper : 1st Recommendation Lower : 2nd Recommendation	Page
--------------	----------------------	-----------	------------	------	---------	--------	----------------	--	------

P

























Corner radius end mills

Long neck (LU-12xDC) / Taper neck (LB2-50xDC)















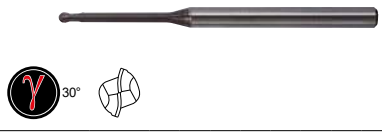







MPXLRB		  DC≤0.3 DC≥0.4	DC 0.2-6	1xDC	2.5 -12xDC	2 4			I120
VFHVRB		 	DC 1-12	1 -1.5xDC	6 -50xDC	4			I153

Ball nose end mills

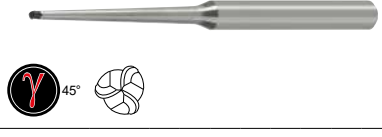
Short / Medium flute (APMX-3xDC)

MP2SSB		 	RE 0.1-6	1xDC	-	2			I079
MP2SB		 	RE 0.1-6	1.5 -1.7xDC	-	2			I080
MP2MB		 	RE 0.25-6	1.8 -3xDC	-	2			I081
MP2SDB		 	RE 0.5-6	1 -2xDC	-	2			I083
VQ4SVB		 	RE 1-6	1.5xDC	-	4			I194

- * APMX : Depth of Cut
- * DC : Cutting Diameter
- * RE : Ball Nose End Mill Radius

Product Name	Coating or Substrate	End Mills	Size Range	APMX	LU LxDC	Flutes	Finish / Rough	Work Materials Upper : 1st Recommendation Lower : 2nd Recommendation	Page
Long neck (LU-20xDC)									
MP2XLB			RE 0.05-3	0.7 -1xDC	1.2 -20xDC	2			I085
VF2XLB			RE 0.1-3	0.8xDC	2.5 -20xDC	2			I129
VF2XLBS			RE 0.2-1	0.8xDC	2.5 -12xDC	2			I127
 VQ4WB			RE 0.5-3	280°	2 -6.2xDC	4			I196
Taper neck (LB2-70xDC)									
MP3XB			RE 0.5-6	0.8 -1.5xDC	3.3 -50xDC	3			I093
VF3XB			RE 0.4-2.5	0.6 -0.9xDC	6.7 -70xDC	3			I135

TOOL NAVI

SOLID END MILLS

Product Name	Coating or Substrate	End Mills	Size Range	APMX	LU LxDC	Flutes	Finish / Rough	Work Materials Upper : 1st Recommendation Lower : 2nd Recommendation	Page
--------------	----------------------	-----------	------------	------	---------	--------	----------------	--	------

H

Square end mills

Medium flute (APMX-3.5xDC)

VFSD		 DC<3 DC≥3 DC<3 DC≥3	DC 1-12	2xDC	-	4 6			I145
VFMD		 DC<3 DC≥3 DC<3 DC≥3	DC 1-25	2 -3.5xDC	-	4 6			I146
VF2MV		 37.5° 	DC 0.5-6	2.5xDC	-	2			I140
VF4MV		 38° 	DC 6-20	2.5xDC	-	4			I142

Long neck (LU-12xDC)

VF2XL		 DC<3 DC=3	DC 0.2-3	1.5 -1.7xDC	2.5 -12xDC	2			I143
-------	--	-----------------------	-------------	----------------	---------------	---	--	--	------





Corner radius end mills

Short / Medium flute (APMX-3.3xDC)









VFHVRB		 45° 	DC 1-16	1 -1.6xDC	-	4			I153
VFSDRB		 	DC 3-12	1xDC	-	6			I150
VFMDRB		 	DC 3-20	2.2 -3.3xDC	-	6			I151
VFFDRB		 DC≤6 DC≥8	DC 3-12	0.06DC	-	4 6			I148

* APMX : Depth of Cut * DC : Cutting Diameter
* RE : Ball Nose End Mill Radius























Product Name	Coating or Substrate	End Mills	Size Range	APMX	LU LxDC	Flutes	Finish / Rough	Work Materials Upper : 1st Recommendation Lower : 2nd Recommendation	Page
NEW VFRPSRB	VFR	  DC≤1.0 DC≥1.5	DC 0.5-12	1 -1.5xDC	2.7 -10xDC	4			I171

Long neck (LU-6xDC) / Taper neck (LB2-50xDC)

MPXLRB	MS	  DC≤0.3 DC≥0.4	DC 0.2-6	1xDC	2.5 -12xDC	2 4			I120
VFHVRB	VF	 	DC 1-12	1 -1.5xDC	6 -50xDC	4			I159











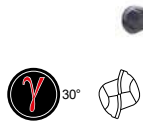



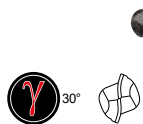



















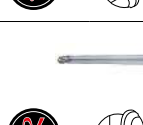

Ball nose end mills

Short / Medium flute (APMX-3xDC)











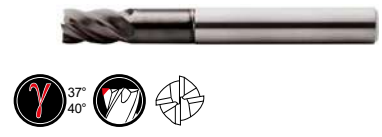

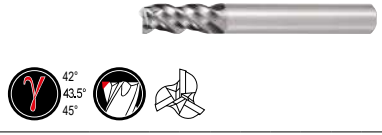









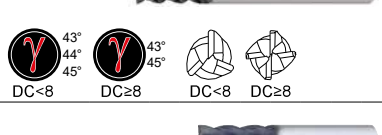

VFR2SB	VFR	  RE<0.3 RE≥0.3	RE 0.1-10	1 -2xDC	-	2			I164
VFR2SBF	VFR	 	RE 0.5-3	1 -2xDC	-	2			I166
VFR2SSB	VFR	 	RE 0.5-6	1xDC	-	2			I163
MP2SSB	MS	 	RE 0.1-6	1xDC	-	2			I079
MP2SB	MS	 	RE 0.1-6	1.5 -1.7xDC	-	2			I080

TOOL NAVI

SOLID END MILLS

Product Name	Coating or Substrate	End Mills	Size Range	APMX	LU LxDC	Flutes	Finish / Rough	Work Materials Upper : 1st Recommendation Lower : 2nd Recommendation	Page
H									
Ball nose end mills									
Short / Medium flute (APMX-3xDC)									
MP2MB	MS		RE 0.25-6	1.8 -3xDC	-	2	F  R 		I081
MP2SDB	MS		RE 0.5-6	1 -2xDC	-	2	F  R 		I083
VF4MB	VF		RE 0.5-6	1.8 -3xDC	-	4	F  R 		I125
Long neck (LU-20xDC) / Taper neck (LB2-70xDC)									
MP2XLB	MS		RE 0.05-3	0.7 -1xDC	1.2 -20xDC	2	F  R 		I085
VF2XLB	VF		RE 0.1-3	0.8xDC	2.5 -20xDC	2	F  R 		I129
VF2XLBS	VF		RE 0.2-1	0.8xDC	2.5 -12xDC	2	F  R 		I127
MP3XB	MS		RE 0.5-6	0.8 -1.5xDC	3.3 -50xDC	3	F  R 		I093
VF3XB	VF		RE 0.4-2.5	0.6 -0.9xDC	6.6 -70xDC	3	F  R 		I135
NEW VFR2XLB	VFR		RE 0.3-3	0.7 -1xDC	2.5 -12xDC	2	F  R 		I168

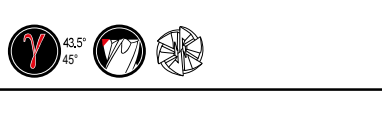
* APMX : Depth of Cut
 * DC : Cutting Diameter
 * RE : Ball Nose End Mill Radius

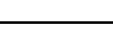
Product Name	Coating or Substrate	End Mills	Size Range	APMX	LU LxDC	Flutes	Finish / Rough	Work Materials Upper : 1st Recommendation Lower : 2nd Recommendation	Page
M									
S									
Square end mills									
Medium flute (APMX-3.5xDC)									
MPSHV/W	MS		DC 6-20	1.5xDC	2.5xDC	4	F  R 	P M H S N	I099
VQMHZV	VQ		DC 1-20	1.6 -2.5xDC	-	3	F  R 	P M S N	I201
VQMHZVOH	VQ		DC 6-16	1.9 -2.4xDC	-	3	F  R 	P M S N	I207
MPMHV/W	MS		DC 6-20	2xDC	2.5xDC	4	F  R 	P M H S N	I101
MPMHV	MS		DC 1-22	2.5xDC	-	4	F  R 	P M H S N	I103
VQMHV	VQ		DC 1-25	2 -2.8xDC	-	4	F  R 	P M S N	I210
VQSVR	VQ		DC 3-20	1.8 -2.4xDC	-	3 4	F  R 	P M S N	I239
VFMHVCH	VF		DC 16,20	2.2xDC	-	4	F  R 	M S P	I178
VF6MHV	VF		DC 6-20	1.9 -2.4xDC	-	6	F  R 	M S P	I177



TOOL NAVI

SOLID END MILLS

Product Name	Coating or Substrate	End Mills	Size Range	APMX	LU LxDC	Flutes	Finish / Rough	Work Materials Upper : 1st Recommendation Lower : 2nd Recommendation	Page
--------------	----------------------	-----------	------------	------	---------	--------	----------------	--	------

M

S

Square end mills

Medium flute (APMX-3.5xDC)

VQ6MHVCH		 43.5° 45°	DC 10-20	1.9 -2.2xDC	-	6	F R	M S P N	I219
VF8MHVCH		 44° 45°	DC 16,20	1.9 -2xDC	-	8	F R	M S P	I179
VFSFPRCH		 30°	DC 16,20	1.9 -2.1xDC	-	4	F R	M S P	I189
VF6SVRCH		 28.5° 30°	DC 16,20	1.9 -2.1xDC	-	6	F R	M S P	I190
VFMFPR		 30°	DC 5-20	2.8 -3.5xDC	-	4	F R	M S P	I188

Semi long (APMX-4xDC)

MPJHV		 37.5° 40° APMX=DCx3.3 38° 40° APMX=DCx4	DC 1-20	3.3 -4xDC	-	4	F R	P M H S N	I106
VQJHV		 36° 40° DC≤6 37.5° 40° DC>6	DC 1-20	3.3 -4xDC	-	4	F R	P M S N	I214

Long neck (LU-6xDC)

VQXL		 35° DC≤0.3 DC≥0.4	DC 0.2-1.0	1.4 -1.67xDC	2.5 -6xDC	3 4	F R	P M S N	I216
VQ4WB			RE 0.5-3	280°	2 -6.2xDC	4	F R	P M S N	I196

* APMX : Depth of Cut * DC : Cutting Diameter
* RE : Ball Nose End Mill Radius



Product Name	Coating or Substrate	End Mills	Size Range	APMX	LU LxDC	Flutes	Finish / Rough	Work Materials Upper : 1st Recommendation Lower : 2nd Recommendation	Page
NEW VQ2XLB		 	RE 0.5-1.5	0.8xDC	4 -12xDC	2	F R	S	I199

Corner radius end mills

Short / Medium flute (APMX-2.8xDC)

MPMHVRB		 	DC 1-20	2.5xDC	-	4	F R	P M H S N	I117
VQMHRB		 	DC 2-20	2 -2.8xDC	-	4	F R	P M S N	I221
VQMHRBF		 	DC 6-16	2.2 -2.4xDC	-	4	F R	P M S N	I226
VFMHRBCH		 	DC 16,20	2.2 -2.3xDC	-	4	F R	M S P	I182
VQT5MVRB		 	DC 16-25	2.2 -2.3xDC	-	5	F R	S	I232
VF6MHRB		 	DC 6-20	1.9 -2.4xDC	-	6	F R	M S P	I180
VQ6MHRBCH		 	DC 10-20	1.9 -2.2xDC	-	6	F R	M S P N	I230
NEW VQFDRB		 	DC3-6	0.06xDC	-	4	F R	S	I234
NEW VQHVRB		 	DC1-4	1xDC	-	4	F R	S	I228

TOOL NAVI

Product Name	Coating or Substrate	End Mills	Size Range	APMX	LU LxDC	Flutes	Finish / Rough	Work Materials Upper : 1st Recommendation Lower : 2nd Recommendation	Page
--------------	----------------------	-----------	------------	------	---------	--------	----------------	--	------

M

S

Corner radius end mills

Short / Medium flute (APMX-3xDC)

VF8MHVRBCH			DC 16,20	1.9 -2xDC	-	8			I184
------------	--	--	-------------	--------------	---	---	--	--	------

Ball nose end mills

Short / Medium flute (APMX-1.5xDC)

NEW VQN2MB			RE 0.5-6	1 -2.4xDC	-	2			I191
NEW VQN4MB			RE 1-6	1 -2.4xDC	-	4			I192
NEW VQN4MBF			RE 1-6	1 -2.4xDC	-	4			I193
VQ4SVB			RE 1-6	1.5xDC	-	4			I194

Long neck (LU-3xDC)

VF2WB			RE 1-3	220° 2 -3xDC	-	2			I176
-------	--	--	-----------	--------------------	---	---	--	--	------

Barrel end mills

Medium flute (APMX-2.6xDC)

VQT6UR			DC 8-12	2 -2.6xDC	-	6			I236
--------	--	--	------------	--------------	---	---	--	--	------













- * APMX : Depth of Cut
- * DC : Cutting Diameter
- * RE : Ball Nose End Mill Radius

Product Name	Coating or Substrate	End Mills	Size Range	APMX	LU LxDC	Flutes	Finish / Rough	Work Materials Upper : 1st Recommendation Lower : 2nd Recommendation	Page
--------------	----------------------	-----------	------------	------	------------	--------	----------------	--	------

S

Ceramic radius end mills

Short flute (APMX=0.75xDC)

CE4SRB		 	DC 6-12	0.75xDC	-	4	F  R 		I242
CE6SRB		 	DC 6-12	0.75xDC	-	6	F  R 		I242

TOOL NAVI

SOLID END MILLS

Product Name	Coating or Substrate	End Mills	Size Range	APMX	LU LxDC	Flutes	Finish / Rough	Work Materials Upper : 1st Recommendation Lower : 2nd Recommendation	Page
--------------	----------------------	-----------	------------	------	---------	--------	----------------	--	------

N

Square end mills

Short flute (APMX=1.5xDC)

AM3SS		 37.5°	DC 10-25	0.8 -1.3xDC	-	3	F R	N	I261
AM2SC		 37.5°	DC 3-20	0.9 -2xDC	-	2	F R	N	I259
AMSR		 37.5°	DC 10-25	1.1 -1.3xDC	-	3	F R	N	I269
NEW A3SA		 37.5°	DC 12-25	1.5xDC	-	3	F R	N	I275
NEW DLC3SA		 37.5°	DC 12-25	1.5xDC	-	3	F R	N	I280

Medium flute (APMX=3.2xDC)























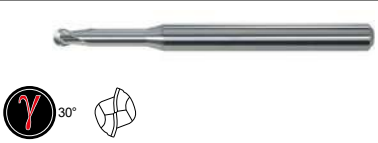



CRN2MS		 30° DC<3 DC≥3	DC 0.2-12	2 -3.2xDC	-	2	F R	N	I249
AM2MR		 55°	DC 3-25	1.5 -3xDC	-	2	F R	N	I260
AM3MF		 50°	DC 6-16	2 -2.4xDC	-	3	F R	N	I262
AM4MF		 50°	DC 20,25	1.8 -1.9xDC	-	4	F R	N	I263

* APMX : Depth of Cut
* DC : Cutting Diameter

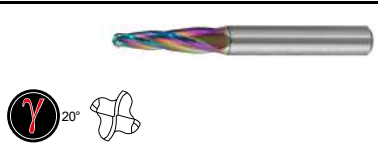
Product Name	Coating or Substrate	End Mills	Size Range	APMX	LU LxDC	Flutes	Finish / Rough	Work Materials Upper : 1st Recommendation Lower : 2nd Recommendation	Page
Medium flute (APMX-3.2xDC)									
AMMR		 37.5°	DC 3-25	1.8 -2.8xDC	-	3	F R		I271
Semi long (APMX-4xDC)									
CRN4JC		 30°	DC 3-12	2.5 -4xDC	-	4	F R		I251
Long neck (LU-16xDC)									
CRN2XL		 30° DC<3 DC≥3	DC 0.3-6	1.5 -1.7xDC	3 -12xDC	2	F R		I252
Corner radius end mills									
Short / Medium flute (APMX-2.4xDC)									
CRN2MRB		 30°	DC 6-12	2.2 -2.4xDC	-	2	F R		I254
AM3SSRB		 37.5°	DC 12-25	0.8 -1.3xDC	-	3	F R		I267
AM2SCRB		 37.5°	DC 3-20	0.9 -2xDC	-	2	F R		I264
NEW A3SARB		 37.5°	DC 12-25	1.5xDC	-	3	F R		I276
NEW DLC3SARB		 37.5°	DC 12-25	1.5xDC	-	3	F R		I281
Long neck (LU-13xDC)									
CRN2XLRB		 30° DC<3 DC≥3	DC 0.5-6	1xDC	5 -12xDC	2	F R		I256

TOOL NAVI

SOLID END MILLS

Product Name	Coating or Substrate	End Mills	Size Range	APMX	LU LxDC	Flutes	Finish / Rough	Work Materials Upper : 1st Recommendation Lower : 2nd Recommendation	Page
N									
Ball nose end mills									
Short / Medium flute (APMX-3xDC)									
CRN2MB			RE 0.2-5	1.8 -3xDC	-	2			I244
AM2MB			RE 0.5-10	1.5 -3xDC	-	2			I258
DC2SB			RE 0.1-3	0.6 -0.7xDC	-	2		 * For hard brittle materials	I291
Long neck (LU-20xDC)									
CRN2XLB			RE 0.15-3	1xDC	2.5 -20xDC	2			I246
DC2XLB			RE 0.1-3	0.6xDC	1.7 -5xDC	2		 * For hard brittle materials	I293
Tapered flute (APMX-20xDC)									
NEW DLC4LATB			RE 0.5-2	6.7 -20xDC	-	4			I278
C4LATB			RE 0.5-2	6.7 -20xDC	-	4			I273

* APMX : Depth of Cut
 * DC : Cutting Diameter
 * RE : Ball Nose End Mill Radius

Product Name	Coating or Substrate	End Mills	Size Range	APMX	LU LxDC	Flutes	Finish / Rough	Work Materials Upper : 1st Recommendation Lower : 2nd Recommendation	Page
--------------	----------------------	-----------	------------	------	---------	--------	----------------	--	------

X















Square end mills

Semi long (APMX-4xDC)

DF4JC		  	DC 3-12	3 -4xDC	-	4	F  R 	X 	I290
DFC4JC		  	DC 6-12	2.5 -3.8xDC	-	4	F  R 	X	I283
DFCJRT		 	DC 6-12	2.5 -3.8xDC	-	10 12	F  R 	X	I284













































Ball nose end mills

Long neck (LU-40xDC)





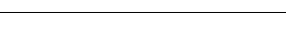





































DF2XLB		  	RE 0.15-2	1 -1.5xDC	4 -40xDC	2	F  R 	X 	I285
DF2XLBF		  	RE 0.3-1.5	0.8 -1.5xDC	5 -20xDC	2	F  R 	X 	I288

END MILLS SELECTION CHART

SOLID END MILLS

Group	Type	Feature	Flutes	Code	Shape	Coating	Substrate	Size range	Work material								Page number		
									P	H	M	S	N	X	Dimensions	Cutting conditions			
									Carbon steel, Alloy steel, Cast iron Tool steel, Pre-Hardened steel, Hardened steel	Hardened steel(—55HRC)	Hardened steel(55HRC—)	Austenitic stainless steel	Titanium alloy, Heat resistant alloy	Copper alloy			Aluminium alloy	Graphite/Cemented Carbide/Quartz Glass	
MSTAR / For general material																			
Square	General		2	MS2SS				DC0.1 —12	<input checked="" type="checkbox"/>	<input checked="" type="checkbox"/>	<input type="checkbox"/>	<input type="checkbox"/>	<input type="checkbox"/>	<input type="checkbox"/>			I036	I039	
				MS2MS				DC0.2 —20	<input checked="" type="checkbox"/>	<input checked="" type="checkbox"/>	<input type="checkbox"/>	<input type="checkbox"/>	<input type="checkbox"/>	<input type="checkbox"/>			I037	I039	
				MS2JS				DC0.1 —12	<input checked="" type="checkbox"/>	<input checked="" type="checkbox"/>	<input type="checkbox"/>	<input type="checkbox"/>	<input type="checkbox"/>	<input type="checkbox"/>			I040	I041	
				MS2LS				DC0.2 —12	<input checked="" type="checkbox"/>	<input checked="" type="checkbox"/>	<input type="checkbox"/>	<input type="checkbox"/>	<input type="checkbox"/>	<input type="checkbox"/>			I042	I043	
				MS4SC				DC1 —12	<input checked="" type="checkbox"/>	<input checked="" type="checkbox"/>	<input type="checkbox"/>	<input type="checkbox"/>	<input type="checkbox"/>	<input type="checkbox"/>			I046	I048	
				MS4MC				DC1 —20	<input checked="" type="checkbox"/>	<input checked="" type="checkbox"/>	<input type="checkbox"/>	<input type="checkbox"/>	<input type="checkbox"/>	<input type="checkbox"/>			I047	I048	
				MS4JC				DC1 —12	<input checked="" type="checkbox"/>	<input checked="" type="checkbox"/>	<input type="checkbox"/>	<input type="checkbox"/>	<input type="checkbox"/>	<input type="checkbox"/>			I049	I050	
	Long neck	2	MS2XL				DC0.2 —6	<input checked="" type="checkbox"/>	<input checked="" type="checkbox"/>	<input type="checkbox"/>	<input type="checkbox"/>	<input type="checkbox"/>			I060	I063			
			MS2XL6				DC0.3 —2.5	<input checked="" type="checkbox"/>	<input checked="" type="checkbox"/>	<input type="checkbox"/>	<input type="checkbox"/>	<input type="checkbox"/>			I064	I066			
			MS4XL				DC1 —10	<input checked="" type="checkbox"/>	<input checked="" type="checkbox"/>	<input type="checkbox"/>	<input type="checkbox"/>	<input type="checkbox"/>	<input type="checkbox"/>			I067	I070		
	High helix	3	MSMHZD				DC1 —20	<input checked="" type="checkbox"/>	<input checked="" type="checkbox"/>	<input type="checkbox"/>	<input type="checkbox"/>	<input type="checkbox"/>			I044	I045			
			MSSH D				DC3 —20	<input checked="" type="checkbox"/>	<input checked="" type="checkbox"/>	<input type="checkbox"/>	<input type="checkbox"/>	<input type="checkbox"/>			I051	I054			
			MSMHD				DC2 —25	<input checked="" type="checkbox"/>	<input checked="" type="checkbox"/>	<input type="checkbox"/>	<input type="checkbox"/>	<input type="checkbox"/>			I052	I054			
	Small lathe	2	MS2ES				DC3 —12	<input checked="" type="checkbox"/>	<input checked="" type="checkbox"/>	<input type="checkbox"/>	<input type="checkbox"/>	<input type="checkbox"/>			I055	I057			
			MS3ES				DC3 —12	<input checked="" type="checkbox"/>	<input checked="" type="checkbox"/>	<input type="checkbox"/>	<input type="checkbox"/>	<input type="checkbox"/>			I056	I057			

* DC : Cutting Diameter
* RE : Ball nose end mill radius

Group	Type	Feature	Flutes	Code	Shape	Coating	Substrate	Size range	Work material										Page number							
									P		H		M	S	N	X	Dimensions	Cutting conditions								
									Carbon steel, Alloy steel, Cast iron	Tool steel, Pre-Hardened steel, Hardened steel	Hardened steel(-55HRC)	Hardened steel(55HRC-)	Austenitic stainless steel	Titanium alloy, Heat resistant alloy	Copper alloy	Aluminium alloy			Graphite/Cemented Carbide/Quartz Glass							
	Square	Small lathe	4	MS4EC				DC3-14	◎	◎	○	○	○	○	○	○	○	○	○	○	○	I058	I059			
	Radius	General	2	MS2MRB				DC1-12	◎	◎	○	○	○	○	○	○	○	○	○	○	○	I071	I073			
			4	MS4MRB				DC3-20	◎	◎	○	○	○	○	○	○	○	○	○	○	○	I074	I076			
	Square	High helix	6	MS6MH-E				DC6-16	◎	◎	○	○	○	○	○	○	○	○	○	○	○	I077	I078			
			8	MS8MH-E				DC20	◎	◎	○	○	○	○	○	○	○	○	○	○	○	○	I077	I078		
MS Plus / For general material																										
	Ball	General	2	MP2SSB				RE 0.1-6	◎	◎	◎	○	○	○	○	○	○	○	○	○	○	I079	I082			
				MP2SB				RE 0.1-6	◎	◎	◎	○	○	○	○	○	○	○	○	○	○	○	○	I080	I082	
				MP2MB				RE 0.25-6	◎	◎	◎	○	○	○	○	○	○	○	○	○	○	○	○	○	I081	I082
				MP2SDB				RE 0.5-6	○	◎	◎	○	○	○	○	○	○	○	○	○	○	○	○	○	I083	I084
				MP2XLB				RE 0.05-3	◎	◎	◎	○	○	○	○	○	○	○	○	○	○	○	○	○	I085	I090
	Square	Long neck	3	MP3XB				RE 0.5-6	◎	◎	◎	○	○	○	○	○	○	○	○	○	○	○	I093	I096		
				MPSHV/W				DC6-20	◎	◎	○	◎	○	○	○	○	○	○	○	○	○	○	I099	I100		
		Short neck	4	MPMHV/W				DC6-20	◎	◎	○	◎	○	○	○	○	○	○	○	○	○	○	I101	I102		
				General	MPMHV				DC1-22	◎	◎	○	◎	○	○	○	○	○	○	○	○	○	○	I103	I104	













































◎ : 1st recommendation / ○ : 2nd recommendation

END MILLS SELECTION CHART

SOLID END MILLS

Group	Type	Feature	Flutes	Code	Shape	Coating	Substrate	Size range	Work material								Page number				
									P	H	M	S	N	X	Dimensions	Cutting conditions					
									Carbon steel, Alloy steel, Cast iron Tool steel, Pre-Hardened steel, Hardened steel	Hardened steel(-55HRC)	Hardened steel(55HRC-)	Austenitic stainless steel	Titanium alloy, Heat resistant alloy	Copper alloy			Aluminium alloy	Graphite/Cemented Carbide/Quartz Glass			
MS Plus / For general material																					
Square	General	Small lathe	4	MPJHV		MS ⁺	UWC	DC1-20	○	○	○		○	○				I106	I107		
			2	MP2ES		MS ⁺	UWC	DC3-10	○	○	○		○	○				I108	I109		
			3	MP3ES		MS ⁺	UWC	DC3-12	○	○	○		○	○				I111	I112		
			4	MP4EC		MS ⁺	UWC	DC3-14	○	○	○		○	○				I114	I115		
	Radius	General	4	MPMHVRB		MS ⁺	UWC	DC1-20	○	○	○		○	○				I117	I119		
		Long neck	2	MPXLRB		MS ⁺	UWC	DC0.2-6	○	○	○		○	○				I120	I123		
IMPACT MIRACLE / For high hardened materials																					
Ball	High speed	Long neck	4	VF4MB		VF	UWC	RE 0.5-6		○	○	○						I125	I126		
			2	VF2XLBS		VF	UWC	RE 0.2-1		○	○	○						I127	I128		
			3	VF2XLB		VF	UWC	RE 0.1-3		○	○	○						I129	I134		
	Square	Taper neck	3	VF3XB		VF	UWC	RE 0.4-2.5		○	○	○						I135	I138		
			Variable helix	2	VF2MV		VF	UWC	DC0.5-6		○	○	○						I140	I141	
				4	VF4MV		VF	UWC	DC6-20		○	○	○						I142	I142	
		2		VF2XL		VF	UWC	DC0.2-3		○	○	○						I143	I144		
		High speed		4	VFSD		VF	UWC	DC1-12		○	○	○						I145	I147	
			6	VFMD		VF	UWC	DC1-25		○	○	○						I146	I147		













































* DC : Cutting Diameter
* RE : Ball nose end mill radius

Group	Type	Feature	Flutes	Code	Shape	Coating	Substrate	Size range	Work material								Page number																												
									P	H	M	S	N	X	Dimensions	Cutting conditions																													
									Carbon steel, Alloy steel, Cast iron Tool steel, Pre-Hardened steel, Hardened steel	Hardened steel(-55HRC)	Hardened steel(55HRC-)	Austenitic stainless steel	Titanium alloy, Heat resistant alloy	Copper alloy			Aluminium alloy	Graphite/Cemented Carbide/Quartz Glass																											
Radius	Variable helix	4 6	VFFDRB				DC3 -12	<input type="checkbox"/>	<input type="checkbox"/>	<input type="checkbox"/>	<input type="checkbox"/>	<input type="checkbox"/>	<input type="checkbox"/>	<input type="checkbox"/>	<input type="checkbox"/>	<input type="checkbox"/>	<input type="checkbox"/>	<input type="checkbox"/>	I148	I149																									
			VFSDRB				DC3 -12	<input type="checkbox"/>	<input type="checkbox"/>	<input type="checkbox"/>	<input type="checkbox"/>	<input type="checkbox"/>	<input type="checkbox"/>	<input type="checkbox"/>	<input type="checkbox"/>	<input type="checkbox"/>	<input type="checkbox"/>	<input type="checkbox"/>	<input type="checkbox"/>	<input type="checkbox"/>	<input type="checkbox"/>	I150	I152																						
	High speed	6	VFMDBR				DC3 -20	<input type="checkbox"/>	<input type="checkbox"/>	<input type="checkbox"/>	<input type="checkbox"/>	<input type="checkbox"/>	<input type="checkbox"/>	<input type="checkbox"/>	<input type="checkbox"/>	<input type="checkbox"/>	<input type="checkbox"/>	<input type="checkbox"/>	<input type="checkbox"/>	<input type="checkbox"/>	<input type="checkbox"/>	I151	I152																						
			Tough milling	4	VFHVRB				DC1 -16	<input checked="" type="checkbox"/>	<input checked="" type="checkbox"/>	<input checked="" type="checkbox"/>	<input type="checkbox"/>	<input type="checkbox"/>	<input type="checkbox"/>	<input type="checkbox"/>	<input type="checkbox"/>	<input type="checkbox"/>	<input type="checkbox"/>	<input type="checkbox"/>	<input type="checkbox"/>	<input type="checkbox"/>	<input type="checkbox"/>	I153	I155																				
IMPACT MIRACLE / For stainless steel, Titanium alloy																																													
Roughing	Ball	Wide ball	2	VF2WB				RE 1-3	<input type="checkbox"/>	<input type="checkbox"/>	<input type="checkbox"/>	<input checked="" type="checkbox"/>	<input checked="" type="checkbox"/>	<input type="checkbox"/>	<input type="checkbox"/>	<input type="checkbox"/>	<input type="checkbox"/>	<input type="checkbox"/>	<input type="checkbox"/>	<input type="checkbox"/>	<input type="checkbox"/>	<input type="checkbox"/>	<input type="checkbox"/>	I176	I176																				
			Square	Variable helix	6	VF6MHV				DC6 -20	<input type="checkbox"/>	<input type="checkbox"/>	<input type="checkbox"/>	<input type="checkbox"/>	<input checked="" type="checkbox"/>	<input checked="" type="checkbox"/>	<input type="checkbox"/>	<input type="checkbox"/>	<input type="checkbox"/>	<input type="checkbox"/>	<input type="checkbox"/>	<input type="checkbox"/>	<input type="checkbox"/>	<input type="checkbox"/>	<input type="checkbox"/>	<input type="checkbox"/>	<input type="checkbox"/>	I177	I177																
	Through coolant	4			VFMHVCH				DC16, 20	<input type="checkbox"/>	<input type="checkbox"/>	<input type="checkbox"/>	<input type="checkbox"/>	<input checked="" type="checkbox"/>	<input checked="" type="checkbox"/>	<input type="checkbox"/>	<input type="checkbox"/>	<input type="checkbox"/>	<input type="checkbox"/>	<input type="checkbox"/>	<input type="checkbox"/>	<input type="checkbox"/>	<input type="checkbox"/>	<input type="checkbox"/>	<input type="checkbox"/>	<input type="checkbox"/>	<input type="checkbox"/>	I178	I178																
		8		VF8MHVCH				DC16, 20	<input type="checkbox"/>	<input type="checkbox"/>	<input type="checkbox"/>	<input type="checkbox"/>	<input checked="" type="checkbox"/>	<input checked="" type="checkbox"/>	<input type="checkbox"/>	<input type="checkbox"/>	<input type="checkbox"/>	<input type="checkbox"/>	<input type="checkbox"/>	<input type="checkbox"/>	<input type="checkbox"/>	<input type="checkbox"/>	<input type="checkbox"/>	<input type="checkbox"/>	<input type="checkbox"/>	<input type="checkbox"/>	<input type="checkbox"/>	I179	I179																
	Radius	Variable helix		6	VF6MHRB				DC6 -20	<input type="checkbox"/>	<input type="checkbox"/>	<input type="checkbox"/>	<input type="checkbox"/>	<input checked="" type="checkbox"/>	<input checked="" type="checkbox"/>	<input type="checkbox"/>	<input type="checkbox"/>	<input type="checkbox"/>	<input type="checkbox"/>	<input type="checkbox"/>	<input type="checkbox"/>	<input type="checkbox"/>	<input type="checkbox"/>	<input type="checkbox"/>	<input type="checkbox"/>	<input type="checkbox"/>	<input type="checkbox"/>	<input type="checkbox"/>	I180	I181															
			Through coolant		4	VFMHRBCH				DC16, 20	<input type="checkbox"/>	<input type="checkbox"/>	<input type="checkbox"/>	<input type="checkbox"/>	<input checked="" type="checkbox"/>	<input checked="" type="checkbox"/>	<input type="checkbox"/>	<input type="checkbox"/>	<input type="checkbox"/>	<input type="checkbox"/>	<input type="checkbox"/>	<input type="checkbox"/>	<input type="checkbox"/>	<input type="checkbox"/>	<input type="checkbox"/>	<input type="checkbox"/>	<input type="checkbox"/>	<input type="checkbox"/>	<input type="checkbox"/>	<input type="checkbox"/>	I182	I183													
		8		VF8MHRBCH				DC16, 20	<input type="checkbox"/>	<input type="checkbox"/>	<input type="checkbox"/>	<input type="checkbox"/>	<input type="checkbox"/>	<input checked="" type="checkbox"/>	<input checked="" type="checkbox"/>	<input type="checkbox"/>	<input type="checkbox"/>	<input type="checkbox"/>	<input type="checkbox"/>	<input type="checkbox"/>	<input type="checkbox"/>	<input type="checkbox"/>	<input type="checkbox"/>	<input type="checkbox"/>	<input type="checkbox"/>	<input type="checkbox"/>	<input type="checkbox"/>	<input type="checkbox"/>	<input type="checkbox"/>	<input type="checkbox"/>	I184	I185													
			General	3 4	VFSFPR				DC3 -20	<input type="checkbox"/>	<input type="checkbox"/>	<input type="checkbox"/>	<input type="checkbox"/>	<input checked="" type="checkbox"/>	<input checked="" type="checkbox"/>	<input type="checkbox"/>	<input type="checkbox"/>	<input type="checkbox"/>	<input type="checkbox"/>	<input type="checkbox"/>	<input type="checkbox"/>	<input type="checkbox"/>	<input type="checkbox"/>	<input type="checkbox"/>	<input type="checkbox"/>	<input type="checkbox"/>	<input type="checkbox"/>	<input type="checkbox"/>	<input type="checkbox"/>	<input type="checkbox"/>	<input type="checkbox"/>	<input type="checkbox"/>	<input type="checkbox"/>	<input type="checkbox"/>	<input type="checkbox"/>	<input type="checkbox"/>	<input type="checkbox"/>	<input type="checkbox"/>	<input type="checkbox"/>	<input type="checkbox"/>	<input type="checkbox"/>	I186	I187		
	Through coolant	4			VFMFPR				DC5 -20	<input type="checkbox"/>	<input type="checkbox"/>	<input type="checkbox"/>	<input type="checkbox"/>	<input checked="" type="checkbox"/>	<input checked="" type="checkbox"/>	<input type="checkbox"/>	<input type="checkbox"/>	<input type="checkbox"/>	<input type="checkbox"/>	<input type="checkbox"/>	<input type="checkbox"/>	<input type="checkbox"/>	<input type="checkbox"/>	<input type="checkbox"/>	<input type="checkbox"/>	<input type="checkbox"/>	<input type="checkbox"/>	<input type="checkbox"/>	<input type="checkbox"/>	<input type="checkbox"/>	<input type="checkbox"/>	<input type="checkbox"/>	<input type="checkbox"/>	<input type="checkbox"/>	<input type="checkbox"/>	<input type="checkbox"/>	<input type="checkbox"/>	<input type="checkbox"/>	<input type="checkbox"/>	<input type="checkbox"/>	<input type="checkbox"/>	<input type="checkbox"/>	I188	I188	
		6		VFSFPRCH				DC16, 20	<input type="checkbox"/>	<input type="checkbox"/>	<input type="checkbox"/>	<input type="checkbox"/>	<input type="checkbox"/>	<input checked="" type="checkbox"/>	<input checked="" type="checkbox"/>	<input type="checkbox"/>	<input type="checkbox"/>	<input type="checkbox"/>	<input type="checkbox"/>	<input type="checkbox"/>	<input type="checkbox"/>	<input type="checkbox"/>	<input type="checkbox"/>	<input type="checkbox"/>	<input type="checkbox"/>	<input type="checkbox"/>	<input type="checkbox"/>	<input type="checkbox"/>	<input type="checkbox"/>	<input type="checkbox"/>	<input type="checkbox"/>	<input type="checkbox"/>	<input type="checkbox"/>	<input type="checkbox"/>	<input type="checkbox"/>	<input type="checkbox"/>	<input type="checkbox"/>	<input type="checkbox"/>	<input type="checkbox"/>	<input type="checkbox"/>	<input type="checkbox"/>	<input type="checkbox"/>	<input type="checkbox"/>	<input type="checkbox"/>	I189
	VF6SVRCH						DC16, 20	<input type="checkbox"/>	<input type="checkbox"/>	<input type="checkbox"/>	<input type="checkbox"/>	<input type="checkbox"/>	<input type="checkbox"/>	<input checked="" type="checkbox"/>	<input checked="" type="checkbox"/>	<input type="checkbox"/>	<input type="checkbox"/>	<input type="checkbox"/>	<input type="checkbox"/>	<input type="checkbox"/>	<input type="checkbox"/>	<input type="checkbox"/>	<input type="checkbox"/>	<input type="checkbox"/>	<input type="checkbox"/>	<input type="checkbox"/>	<input type="checkbox"/>	<input type="checkbox"/>	<input type="checkbox"/>	<input type="checkbox"/>	<input type="checkbox"/>	<input type="checkbox"/>	<input type="checkbox"/>	<input type="checkbox"/>	<input type="checkbox"/>	<input type="checkbox"/>	<input type="checkbox"/>	<input type="checkbox"/>	<input type="checkbox"/>	<input type="checkbox"/>	<input type="checkbox"/>	<input type="checkbox"/>	<input type="checkbox"/>	<input type="checkbox"/>	<input type="checkbox"/>













































◎ : 1st recommendation / ○ : 2nd recommendation

END MILLS SELECTION CHART

SOLID END MILLS

Group	Type	Feature	Flutes	Code	Shape	Coating	Substrate	Size range	Work material								Page number								
									P	H	M	S	N	X	Dimensions	Cutting conditions									
									Carbon steel, Alloy steel, Cast iron Tool steel, Pre-Hardened steel, Hardened steel	Hardened steel(-55HRC)	Hardened steel(55HRC-)	Austenitic stainless steel	Titanium alloy, Heat resistant alloy	Copper alloy			Aluminium alloy	Graphite/Cemented Carbide/Quartz Glass							
VFR / For hardened steel																									
Ball	High speed	Long neck	2	VFR2SSB				RE 0.5-6	<input type="checkbox"/>	<input checked="" type="checkbox"/>	<input checked="" type="checkbox"/>							I163	I165						
				VFR2SB				RE0.1-10	<input type="checkbox"/>	<input checked="" type="checkbox"/>	<input checked="" type="checkbox"/>									I164	I165				
				NEW VFR2XLB				RE 0.3-3	<input type="checkbox"/>	<input checked="" type="checkbox"/>	<input checked="" type="checkbox"/>										I168	I170			
				VFR2SBF				RE 0.5-3	<input type="checkbox"/>	<input checked="" type="checkbox"/>	<input checked="" type="checkbox"/>										I166	I167			
	Radius	High precision		NEW VFRPSRB				DC0.5-12	<input type="checkbox"/>	<input checked="" type="checkbox"/>	<input checked="" type="checkbox"/>								I171	I174					
VQ/ For stainless steel, Titanium alloy VQN/ For Nickel based alloy VQT/ For Titanium alloy																									
Square	Variable helix	3	VQMHZV				DC1-20	<input checked="" type="checkbox"/>	<input checked="" type="checkbox"/>		<input checked="" type="checkbox"/>	<input checked="" type="checkbox"/>	<input type="checkbox"/>					I201	I203						
			VQMZHVOH				DC6-16	<input checked="" type="checkbox"/>	<input checked="" type="checkbox"/>		<input checked="" type="checkbox"/>	<input checked="" type="checkbox"/>	<input type="checkbox"/>						I207	I208					
			VQXL				DC0.2-1	<input checked="" type="checkbox"/>	<input checked="" type="checkbox"/>		<input checked="" type="checkbox"/>	<input checked="" type="checkbox"/>	<input type="checkbox"/>						I216	I217					
		VQMHV				DC1-25	<input checked="" type="checkbox"/>	<input checked="" type="checkbox"/>		<input checked="" type="checkbox"/>	<input checked="" type="checkbox"/>	<input type="checkbox"/>						I210	I211						
		VQJHV				DC1-20	<input checked="" type="checkbox"/>	<input checked="" type="checkbox"/>		<input checked="" type="checkbox"/>	<input checked="" type="checkbox"/>	<input type="checkbox"/>						I214	I215						
		Through coolant	6	VQ6MHVCH				DC10-20	<input type="checkbox"/>	<input type="checkbox"/>		<input checked="" type="checkbox"/>	<input checked="" type="checkbox"/>	<input type="checkbox"/>					I219	I220					
	Ball	Variable helix	4	VQ4SVB				RE 1-6	<input checked="" type="checkbox"/>	<input checked="" type="checkbox"/>		<input checked="" type="checkbox"/>	<input checked="" type="checkbox"/>	<input type="checkbox"/>					I194	I195					
				NEW VQ4WB				RE 0.5-3	<input checked="" type="checkbox"/>	<input checked="" type="checkbox"/>		<input checked="" type="checkbox"/>	<input checked="" type="checkbox"/>	<input type="checkbox"/>						I196	I197				
		High Efficiency	2	NEW VQN2MB				RE 0.5-6				<input checked="" type="checkbox"/>							I191	I191					
				NEW VQN4MB				RE 1-6				<input checked="" type="checkbox"/>								I192	I192				





































* DC : Cutting Diameter
* RE : Ball nose end mill radius

Group	Type	Feature	Flutes	Code	Shape	Coating	Substrate	Size range	Work material								Page number				
									P	H	M	S	N	X	Dimensions	Cutting conditions					
									Carbon steel, Alloy steel, Cast iron Tool steel, Pre-Hardened steel, Hardened steel	Hardened steel(–55HRC)	Hardened steel(55HRC–)	Austenitic stainless steel	Titanium alloy, Heat resistant alloy	Copper alloy			Aluminium alloy	Graphite/Cemented Carbide/Quartz Glass			
Radius	Ball	High Efficiency	4	NEW VQN4MBF				RE 1–6										I193	I193		
		Long neck	2	NEW VQ2XLB				RE0.5 –1.5											I199	I200	
	Variable helix	4	VQMHV RB				DC2 –20	⊙	⊙			⊙	⊙	○					I221	I223	
		4	VQMHV RBF				DC6 –16	⊙	⊙			⊙	⊙	○					I226	I227	
		5	VQT5MVRB				DC16 –25					⊙	⊙						I232	I233	
	Through coolant	6	VQ6MHV RBCH				DC10 –20	○	○			⊙	⊙	○					I230	I231	
	Duplex Radius	4	NEW VQFDRB				DC 3–6							⊙					I234	I235	
	Variable Helix	4	NEW VQHVRB				DC 1–4							⊙					I228	I229	
	Roughing	Variable Helix	3 4	VQSVR				DC3 –20	⊙	⊙			⊙	⊙	○					I239	I240
		Finish Cutting	6	VQT6UR				DC8 –12	○						○	⊙	○			I236	I237
CRN / For Copper																					
Square	Ball	General		CRN2MB				RE 0.2–5									⊙	○	I244	I245	
		Long neck	2	CRN2XLB				RE 0.15–3										⊙	○	I246	I248
	General		CRN2MS				DC0.2 –12											⊙	○	I249	I250
		4	CRN4JC				DC3 –12											⊙	○	I251	I251
		Long neck	2	CRN2XL				DC0.3 –6											⊙	○	I252



























⊙ : 1st recommendation / ○ : 2nd recommendation

END MILLS SELECTION CHART

SOLID END MILLS

Group	Type	Feature	Flutes	Code	Shape	Coating	Substrate	Size range	Work material								Page number				
									P	H	M	S	N	X	Dimensions	Cutting conditions					
									Carbon steel, Alloy steel, Cast iron Tool steel, Pre-Hardened steel, Hardened steel	Hardened steel(-55HRC)	Hardened steel(55HRC-)	Austenitic stainless steel	Titanium alloy, Heat resistant alloy	Copper alloy			Aluminium alloy	Graphite/Cemented Carbide/Quartz Glass			
CRN / For Copper																					
Radius	General	2	CRN2MRB				DC6 -12											I254	I255		
			Long neck	CRN2XLRB				DC0.5 -6											I256	I257	
DIAMOND (DFC) / For CFRP																					
Square	General	4	DFC4JC				DC6 -12	CFRP : ◎								I283	I283				
		10 12	DFCJRT				DC6 -12									I284	I284				
DIAMOND (DF) / For Graphite																					
Ball	Long neck	2	DF2XLB				RE 0.15-2	GFRP : ○ CFRP : ○ Machineable Ceramics : ○ Zirconia : ◎ Rigid Composite Resin : ◎ Machineable Ceramics : ○								I285	I286				
			DF2XLB				RE0.3 -1.5									I288	I289				
Square	General	4	DF4JC				DC3 -12	GFRP : ○ CFRP : ○ Machineable Ceramics : ○								I290	I290				
DC / For hard brittle materials																					
Ball	General	2	DC2SB				RE 0.1-3	Cemented Carbide : ◎ Alumina : ○ Zirconia : ○ Silicon Carbide : ○ Silicon Nitride : ○ Quartz Glass : ○								I291	I292				
			Long neck	DC2XLB												RE 0.1-3	I293	I294			
DLC / For Aluminium alloy																					
Ball	Taper ball	4	NEW DLC4LATB				RE 0.5-2											I278	I279		
Square	Through coolant	3	NEW DLC3SA				DC12 -25											I280	I282		
Radius			DLC3SARB				DC12 -25												I281	I282	























* DC : Cutting Diameter
* RE : Ball nose end mill radius

Group	Type	Feature	Flutes	Code	Shape	Coating	Substrate	Size range	Work material								Page number								
									P	H	M	S	N	X	Dimensions	Cutting conditions									
									Carbon steel, Alloy steel, Cast iron Tool steel, Pre-Hardened steel, Hardened steel	Hardened steel(—55HRC)	Hardened steel(55HRC—)	Austenitic stainless steel	Titanium alloy, Heat resistant alloy	Copper alloy			Aluminium alloy	Graphite/Cemented Carbide/Quartz Glass							
CERAMIC																									
	Radius	High speed	4	CE4SRB		—		DC6 —12												I242	I243				
			6	CE6SRB		—		DC6 —12																	
ALIMASTER / For Aluminium alloy																									
	Ball	General	2	AM2MB		—		RE 0.5—10													I258	I258			
		Taper ball	4	C4LATB		—		RE 0.5—2															I273	I274	
	Square	General	2	AM2MR		—		DC3 —25														I260	I260		
				AM2SC		—		DC3 —20																I259	I259
			3	AM3SS		—		DC10 —25																I261	I261
				AM3MF		—		DC6 —16																	I262
	Radius	Long neck	4	AM4MF		—		DC20, 25															I263	I263	
				2	AM2SCRB		—		DC3 —20																I264
			3	AM3SSRB		—		DC12 —25																	I267
	Square	Through coolant	3	NEW A3SA		—		DC12 —25															I275	I277	
	Radius		3	NEW A3SARB		—		DC12 —25																I276	I277

◎ : 1st recommendation / ○ : 2nd recommendation

END MILLS SELECTION CHART

SOLID END MILLS

Group	Type	Feature	Flutes	Code	Shape	Coating	Substrate	Size range	Work material							Page number				
									P	H	M	S	N	X	Dimensions	Cutting conditions				
									Carbon steel, Alloy steel, Cast iron Tool steel, Pre-Hardened steel, Hardened steel	Hardened steel(—55HRC)	Hardened steel(55HRC—)	Austenitic stainless steel	Titanium alloy, Heat resistant alloy	Copper alloy			Aluminium alloy	Graphite/Cemented Carbide/Quartz Glass		
ALIMASTER / For Aluminium alloy																				
Roughing	General		3	AMSR		—		DC10 —25											I269 I270	
				AMMR		—		DC3 —25												I271 I272
VIOLET / For general materials																				
Square	General		2	VA2SS				DC3 —20	○	○			○	○					I295 I297	
				VA2MS				DC3 —22	○	○			○	○						I296 I297
				VA4MC				DC3 —25	○	○			○	○						
Roughing	General		4 5	VASFPR				DC5 —30	○	○			○	○					I300 I301	
				VAMFPR				DC5 —30	○	○			○	○						I302 I303
				VAMR				DC5 —32	○	○			○	○						

* DC : Cutting Diameter

Memo

A series of horizontal dashed lines for writing.

MSTAR END MILLS

MS2SS

End mill, Short cut length, 2 flute



Carbon Steel, Alloy Steel, Cast Iron (<30HRC)	Tool Steel, Pre-Hardened Steel, Hardened Steel (≤45HRC)	Hardened Steel (≤55HRC)	Hardened Steel (>55HRC)	Austenitic Stainless Steel	Titanium Alloy, Heat Resistant Alloy	Copper Alloy	Aluminium Alloy
○	○	○	○	○	○	○	○

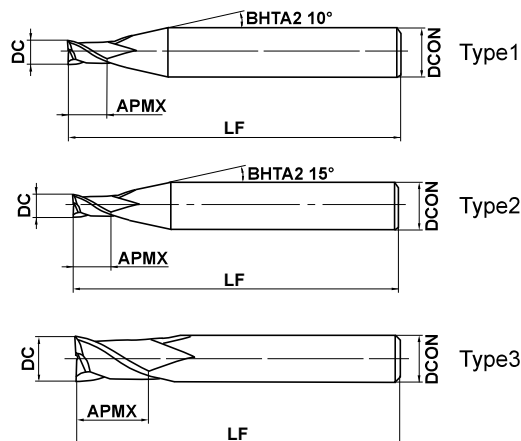

	DC=0.1	DC>0.1			
	0 - 0.010	0 - 0.020			
	$4 \leq DCON \leq 6$	$8 \leq DCON \leq 10$	DCON=12		
	0 - 0.008	0 - 0.009	0 - 0.011		

● 2 flute end mill for general use.

(mm)

Order Number	DC	APMX	LF	DCON	Flutes	Stock	Type
MS2SSD0010	0.1	0.15	40	4	2	●	1
MS2SSD0020	0.2	0.3	40	4	2	●	2
MS2SSD0030	0.3	0.45	40	4	2	●	2
MS2SSD0040	0.4	0.6	40	4	2	●	2
MS2SSD0050	0.5	0.75	40	4	2	●	2
MS2SSD0060	0.6	0.9	40	4	2	●	2
MS2SSD0070	0.7	1.1	40	4	2	●	2
MS2SSD0080	0.8	1.2	40	4	2	●	2
MS2SSD0090	0.9	1.4	40	4	2	●	2
MS2SSD0100	1	1.5	40	4	2	●	2
MS2SSD0120	1.2	1.8	40	4	2	●	2
MS2SSD0150	1.5	2.3	40	4	2	●	2
MS2SSD0180	1.8	2.7	40	4	2	●	2
MS2SSD0200	2	3	40	4	2	●	2
MS2SSD0250	2.5	3.8	40	4	2	●	2
MS2SSD0300	3	4.5	45	6	2	●	2
MS2SSD0400	4	6	50	6	2	●	2
MS2SSD0500	5	7.5	50	6	2	●	2
MS2SSD0600	6	9	50	6	2	●	3
MS2SSD0700	7	10.5	60	8	2	●	2
MS2SSD0800	8	12	60	8	2	●	3
MS2SSD0900	9	13.5	70	10	2	●	2
MS2SSD1000	10	15	70	10	2	●	3
MS2SSD1100	11	16.5	75	12	2	●	2
MS2SSD1200	12	18	75	12	2	●	3

● : Inventory maintained. ★ : Inventory maintained in Japan.

MS2MS

End mill, Medium cut length, 2 flute



CARBIDE

Carbon Steel, Alloy Steel, Cast Iron (<30HRC)	Tool Steel, Pre-Hardened Steel, Hardened Steel (≤45HRC)	Hardened Steel (≤55HRC)	Hardened Steel (>55HRC)	Austenitic Stainless Steel	Titanium Alloy, Heat Resistant Alloy	Copper Alloy	Aluminium Alloy
○	○	○	○	○	○	○	○

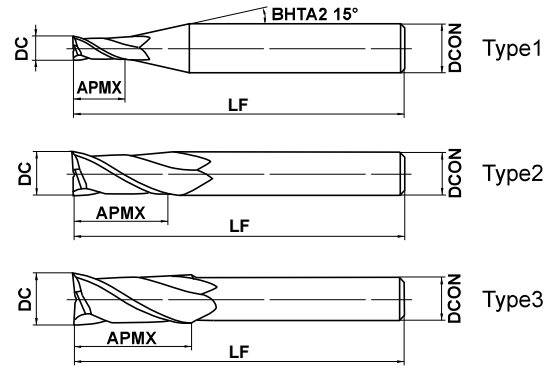

DC ≤ 12	DC > 12			
0 - 0.020	0 - 0.030			
4 ≤ DCON ≤ 6	8 ≤ DCON ≤ 10	12 ≤ DCON ≤ 16	DCON = 20	
0 - 0.008	0 - 0.009	0 - 0.011	0 - 0.013	



● 2 flute end mill for general use.

(mm)

Order Number	DC	APMX	LF	DCON	Flutes	Stock	Type
MS2MSD0020	0.2	0.4	40	4	2	●	1
MS2MSD0030	0.3	0.6	40	4	2	●	1
MS2MSD0040	0.4	0.8	40	4	2	●	1
MS2MSD0050	0.5	1	40	4	2	●	1
MS2MSD0060	0.6	1.2	40	4	2	●	1
MS2MSD0070	0.7	1.4	40	4	2	●	1
MS2MSD0080	0.8	1.6	40	4	2	●	1
MS2MSD0090	0.9	1.8	40	4	2	●	1
MS2MSD0100	1	2	40	4	2	●	1
MS2MSD0110	1.1	2.2	40	4	2	●	1
MS2MSD0120	1.2	2.4	40	4	2	●	1
MS2MSD0130	1.3	2.6	40	4	2	●	1
MS2MSD0140	1.4	2.8	40	4	2	●	1
MS2MSD0150	1.5	3	40	4	2	●	1
MS2MSD0160	1.6	3.2	40	4	2	●	1
MS2MSD0170	1.7	3.4	40	4	2	●	1
MS2MSD0180	1.8	3.6	40	4	2	●	1
MS2MSD0190	1.9	3.8	40	4	2	●	1
MS2MSD0200	2	4	40	4	2	●	1
MS2MSD0210	2.1	4.2	40	4	2	●	1
MS2MSD0220	2.2	4.4	40	4	2	●	1
MS2MSD0230	2.3	4.6	40	4	2	●	1
MS2MSD0240	2.4	4.8	40	4	2	●	1
MS2MSD0250	2.5	5	40	4	2	●	1
MS2MSD0260	2.6	5.2	40	4	2	●	1
MS2MSD0270	2.7	5.4	40	4	2	●	1
MS2MSD0280	2.8	5.6	40	4	2	●	1
MS2MSD0290	2.9	5.8	40	4	2	●	1
MS2MSD0300	3	6	45	6	2	●	1
MS2MSD0310	3.1	6.2	45	6	2	★	1
MS2MSD0320	3.2	6.4	45	6	2	★	1
MS2MSD0330	3.3	6.6	45	6	2	★	1
MS2MSD0340	3.4	6.8	45	6	2	★	1
MS2MSD0350	3.5	7	45	6	2	●	1

SOLID END MILLS

SQUARE

BALL

RADIUS

TAPER

BARREL

ROUGHING

MSTAR END MILLS

MS2MS

End mill, Medium cut length, 2 flute

(mm)

Order Number	DC	APMX	LF	DCON	Flutes	Stock	Type
MS2MSD0360	3.6	7.2	45	6	2	★	1
MS2MSD0370	3.7	7.4	45	6	2	★	1
MS2MSD0380	3.8	7.6	45	6	2	★	1
MS2MSD0390	3.9	7.8	45	6	2	★	1
MS2MSD0400	4	8	50	6	2	●	1
MS2MSD0410	4.1	8.2	50	6	2	★	1
MS2MSD0420	4.2	8.4	50	6	2	★	1
MS2MSD0430	4.3	8.6	50	6	2	★	1
MS2MSD0440	4.4	8.8	50	6	2	★	1
MS2MSD0450	4.5	9	50	6	2	●	1
MS2MSD0460	4.6	9.2	50	6	2	★	1
MS2MSD0470	4.7	9.4	50	6	2	★	1
MS2MSD0480	4.8	9.6	50	6	2	★	1
MS2MSD0490	4.9	9.8	50	6	2	★	1
MS2MSD0500	5	10	50	6	2	●	1
MS2MSD0510	5.1	10.2	50	6	2	★	1
MS2MSD0520	5.2	10.4	50	6	2	★	1
MS2MSD0530	5.3	10.6	50	6	2	★	1
MS2MSD0540	5.4	10.8	50	6	2	★	1
MS2MSD0550	5.5	11	50	6	2	●	1
MS2MSD0560	5.6	11.2	50	6	2	★	1
MS2MSD0570	5.7	11.4	50	6	2	★	1
MS2MSD0580	5.8	11.6	50	6	2	★	1
MS2MSD0590	5.9	11.8	50	6	2	★	1
MS2MSD0600	6	12	50	6	2	●	2
MS2MSD0650	6.5	13	60	8	2	●	1
MS2MSD0700	7	14	60	8	2	●	1
MS2MSD0750	7.5	15	60	8	2	●	1
MS2MSD0800	8	16	60	8	2	●	2
MS2MSD0850	8.5	17	70	10	2	●	1
MS2MSD0900	9	18	70	10	2	●	1
MS2MSD0950	9.5	19	70	10	2	●	1
MS2MSD1000	10	20	70	10	2	●	2
MS2MSD1100	11	22	75	12	2	●	1
MS2MSD1200	12	24	75	12	2	●	2
MS2MSD1600	16	32	90	16	2	●	2
MS2MSD1800	18	36	90	16	2	●	3
MS2MSD2000	20	40	100	20	2	●	2

● : Inventory maintained. ★ : Inventory maintained in Japan.

MS2SS

End mill, Short cut length, 2 flute

MS2MS

End mill, Medium cut length, 2 flute

CARBIDE

RECOMMENDED CUTTING CONDITIONS

Work material	P			H		
	Revolution (min ⁻¹)	Feed rate (mm/min)	Depth of cut (mm)	Revolution (min ⁻¹)	Feed rate (mm/min)	Depth of cut (mm)
Carbon steel, Cast iron, Alloy steel, Pre-hardened steel				Hardened steel (45—55HRC)		
Cf53, GG25				X40CrMoV51		
Dia. DC (mm)	Revolution (min ⁻¹)	Feed rate (mm/min)	Depth of cut (mm)	Revolution (min ⁻¹)	Feed rate (mm/min)	Depth of cut (mm)
0.1	40000	40	0.001	40000	40	0.001
0.2	40000	100	0.002	40000	100	0.002
0.3	40000	200	0.005	40000	200	0.005
0.4	40000	600	0.01	40000	600	0.01
0.5	40000	1000	0.015	40000	960	0.015
0.6	40000	1200	0.02	40000	1200	0.02
0.7	40000	1400	0.02	40000	1400	0.02
0.8	40000	1600	0.03	40000	1600	0.03
0.9	40000	1800	0.04	40000	1600	0.04
1	40000	2000	0.06	32000	1600	0.06
1.5	40000	3000	0.12	32000	1900	0.08
2	30000	3000	0.18	24000	1900	0.10
2.5	24000	2600	0.25	19000	1600	0.13
3	20000	2300	0.30	16000	1400	0.15
4	15000	2000	0.40	12000	1200	0.20
5	12000	1600	0.50	9000	900	0.25
6	10000	1400	0.60	7000	700	0.30
8	8000	1000	0.80	5600	550	0.40
10	6400	900	1.00	4500	500	0.50
12	5400	820	1.00	3800	450	0.50
16	2400	380	3.00	1200	100	0.80
20	1900	320	4.00	1000	80	1.00

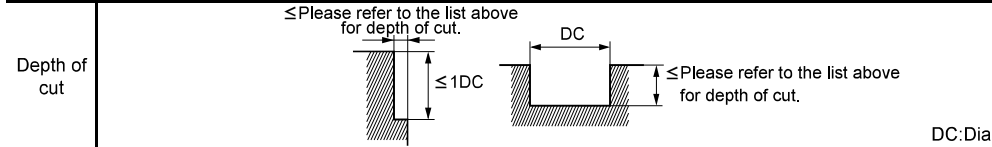

Note 1) If the depth of cut is shallow, the revolution and feed rate can be increased.

Note 2) When slotting with end mills of $\phi 3$ or larger, reduce the revolution by 30—50% and the feed rate by 40—60%.

Note 3) When drilling, please set the feed rate at 1/3 or below the values above.

Note 4) If the rigidity of the machine or the work materials installation is very low, or chattering and noise are generated, reduce the revolution and feed rate proportionately.

SOLID END MILLS

SQUARE

BALL

RADIUS

TAPER

BARREL

ROUGHING

MSTAR END MILLS

MS2JS

End mill, Semi long cut length, 2 flute



DC<3

DC≥3

DC<3

DC≥3

Carbon Steel, Alloy Steel, Cast Iron (<30HRC)	Tool Steel, Pre-Hardened Steel, Hardened Steel (≤45HRC)	Hardened Steel (≤55HRC)	Hardened Steel (>55HRC)	Austenitic Stainless Steel	Titanium Alloy, Heat Resistant Alloy	Copper Alloy	Aluminium Alloy
○	○	○	○	○	○	○	○

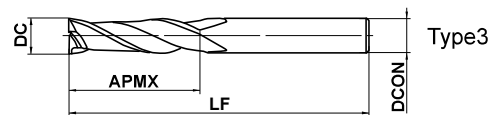
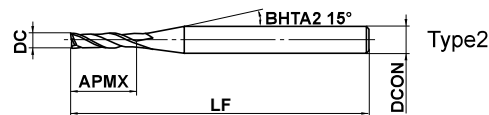
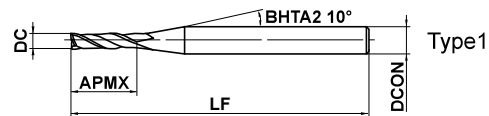

DC=0.1	DC>0.1			
0 - 0.01	0 - 0.02			
4 ≤ DCON ≤ 6	8 ≤ DCON ≤ 10	DCON=12		
0 - 0.008	0 - 0.009	0 - 0.011		

● 2 flute end mill for general use.

(mm)

Order Number	DC	APMX	LF	DCON	Flutes	Stock	Type
MS2JSD0010	0.1	0.3	40	4	2	●	1
MS2JSD0020	0.2	0.6	40	4	2	●	2
MS2JSD0030	0.3	0.9	40	4	2	●	2
MS2JSD0040	0.4	1.2	40	4	2	●	2
MS2JSD0050	0.5	1.5	40	4	2	●	2
MS2JSD0060	0.6	1.8	40	4	2	●	2
MS2JSD0070	0.7	2.1	40	4	2	●	2
MS2JSD0080	0.8	2.4	40	4	2	●	2
MS2JSD0090	0.9	2.7	40	4	2	●	2
MS2JSD0100	1	3	40	4	2	●	2
MS2JSD0120	1.2	3.6	40	4	2	●	2
MS2JSD0150	1.5	4.5	40	4	2	●	2
MS2JSD0180	1.8	5.4	40	4	2	●	2
MS2JSD0200	2	6	40	4	2	●	2
MS2JSD0250	2.5	7.5	40	4	2	●	2
MS2JSD0300	3	9	45	6	2	●	2
MS2JSD0400	4	12	50	6	2	●	2
MS2JSD0500	5	15	50	6	2	●	2
MS2JSD0600	6	18	50	6	2	●	3
MS2JSD0800	8	24	70	8	2	●	3
MS2JSD1000	10	30	90	10	2	●	3
MS2JSD1200	12	36	90	12	2	●	3

● : Inventory maintained.

RECOMMENDED CUTTING CONDITIONS

Work material	P				M	S	H	
	Carbon steel, Cast iron, Alloy steel (–30HRC) Cf53, GG25		Alloy steel, Tool steel, Pre-hardened steel X40CrMoV51		Austenitic stainless steel, Titanium alloy X5CrNi1810, X5CrNiMo17122, Ti6Al4V	Hardened steel (45–55HRC) X40CrMoV51		
Dia. DC (mm)	Revolution (min ⁻¹)	Feed rate (mm/min)	Revolution (min ⁻¹)	Feed rate (mm/min)	Revolution (min ⁻¹)	Feed rate (mm/min)	Revolution (min ⁻¹)	Feed rate (mm/min)
0.1	40000	– (40)	40000	– (40)	40000	– (35)	40000	– (25)
0.2	40000	– (45)	40000	– (45)	40000	– (35)	32000	– (25)
0.3	40000	– (55)	32000	– (45)	27000	– (35)	21000	– (25)
0.4	32000	– (60)	24000	– (45)	20000	– (35)	16000	– (25)
0.5	25000	– (60)	19000	– (45)	16000	– (35)	13000	– (25)
0.6	21000	– (60)	16000	– (45)	13000	– (35)	11000	– (25)
0.7	18000	– (60)	14000	– (45)	11000	– (35)	9100	– (25)
0.8	16000	– (60)	12000	– (45)	9900	– (35)	8000	– (25)
0.9	14000	– (60)	11000	– (45)	8800	– (35)	7100	– (25)
1	13000	60 (60)	9500	45 (45)	8000	35 (35)	6400	25 (25)
1.5	8500	60 (60)	6400	45 (45)	5300	35 (35)	4200	25 (25)
2	6400	60 (60)	4800	45 (45)	4000	35 (35)	3200	25 (25)
2.5	5100	60 (60)	3800	45 (45)	3200	40 (40)	2500	25 (25)
3	4200	65 (60)	3400	55 (45)	2600	40 (40)	2100	25 (25)
4	3400	80 (60)	2700	65 (45)	2100 (1600)	50 (30)	1700	35 (25)
5	2900	100 (60)	2300	80 (45)	1800 (1350)	60 (30)	1500	40 (25)
6	2500	120 (60)	2000	100 (50)	1500 (1100)	75 (30)	1300	50 (25)
8	1900	130 (60)	1500	100 (50)	1200 (900)	80 (30)	1000	50 (25)
10	1600	130 (60)	1300	100 (50)	950 (710)	75 (30)	800	50 (25)
12	1300	120 (60)	1100	100 (50)	800 (600)	75 (30)	670	50 (25)

Depth of cut	Standard		Slotted	
	DC	Feed rate	DC	Feed rate
DC ≥ φ1	≤ 0.05DC (MAX. 0.5mm)	≤ 2.5DC	≤ 0.02DC	≤ 2DC
	DC	≤ 0.02DC (DC < φ0.5) ≤ 0.05DC (φ0.5 ≤ DC < φ1) ≤ 0.1DC (φ1 ≤ DC < φ2) ≤ 0.2DC (DC ≥ φ2)	DC	≤ 0.02DC (DC < φ0.5) ≤ 0.05DC (DC ≤ φ0.5)

() : Indicates standard revolution and feed rate for slotting.

DC: Dia.

Note 1) When cutting austenitic stainless steels, the use of water-soluble cutting fluid is effective.

Note 2) If the depth of cut is shallow, the revolution and feed rate can be increased.

Note 3) When drilling, please set the feed rate at 1/3 or below the values above.

Note 4) If the rigidity of the machine or the work materials installation is very low, or chattering and noise are generated, reduce the revolution and feed rate proportionately.

SOLID END MILLS

SQUARE

BALL

RADIUS

TAPER

BARREL

ROUGHING

MSTAR END MILLS

MS2LS

End mill, Long cut length, 2 flute



DC<3

DC≥3

DC<3

DC≥3

Carbon Steel, Alloy Steel, Cast Iron (<30HRC)	Tool Steel, Pre-Hardened Steel, Hardened Steel (≤45HRC)	Hardened Steel (≤55HRC)	Hardened Steel (>55HRC)	Austenitic Stainless Steel	Titanium Alloy, Heat Resistant Alloy	Copper Alloy	Aluminium Alloy
○	○	○	○	○	○	○	○

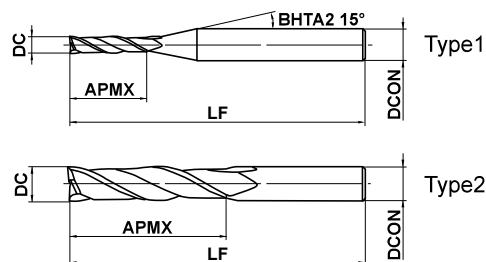

SOLID END MILLS



0.2 ≤ DC ≤ 12				
0				
-0.020				
4 ≤ DCON ≤ 6	8 ≤ DCON ≤ 10	DCON = 12		
0	0	0		
-0.008	-0.009	-0.011		

● 2 flute end mill for general use.

(mm)

Order Number	DC	APMX	LF	DCON	Flutes	Stock	Type
MS2LSD0020	0.2	0.8	40	4	2	★	1
MS2LSD0030	0.3	1.2	40	4	2	★	1
MS2LSD0040	0.4	1.6	40	4	2	★	1
MS2LSD0050	0.5	2	40	4	2	★	1
MS2LSD0060	0.6	2.4	40	4	2	★	1
MS2LSD0070	0.7	2.8	40	4	2	★	1
MS2LSD0080	0.8	3.2	40	4	2	★	1
MS2LSD0090	0.9	3.6	40	4	2	★	1
MS2LSD0100	1	4	40	4	2	★	1
MS2LSD0150	1.5	6	40	4	2	★	1
MS2LSD0200	2	8	40	4	2	★	1
MS2LSD0250	2.5	10	50	4	2	★	1
MS2LSD0300	3	12	50	6	2	★	1
MS2LSD0400	4	16	50	6	2	★	1
MS2LSD0500	5	20	60	6	2	★	1
MS2LSD0600	6	24	60	6	2	★	2
MS2LSD0800	8	32	70	8	2	★	2
MS2LSD1000	10	40	90	10	2	★	2
MS2LSD1200	12	48	110	12	2	★	2

SQUARE

BALL

RADIUS

TAPER

BARREL

ROUGHING

★ : Inventory maintained in Japan.

RECOMMENDED CUTTING CONDITIONS

■ Slotting

Work material	P					
	Carbon steel, Cast iron, Alloy steel (–30HRC) Cf53, GG25			Alloy steel, Tool steel, Pre-hardened steel X40CrMoV51		
Dia. DC (mm)	Revolution (min ⁻¹)	Feed rate (mm/min)	Depth of cut (mm)	Revolution (min ⁻¹)	Feed rate (mm/min)	Depth of cut (mm)
0.2	40000	400	0.001	30000	250	0.001
0.3	40000	600	0.005	35000	420	0.005
0.4	40000	700	0.007	30000	420	0.007
0.5	40000	800	0.01	24000	380	0.01
0.6	33000	800	0.015	21000	480	0.01
0.7	28000	800	0.015	18000	480	0.015
0.8	25000	800	0.02	16000	480	0.02
0.9	22000	800	0.03	15000	500	0.03
1	20000	800	0.04	13000	500	0.04
1.5	13000	800	0.10	9000	500	0.10
2	10000	800	0.15	6700	500	0.15
2.5	9000	800	0.20	6000	500	0.20
3	8000	800	0.20	5200	460	0.20
4	6000	600	0.20	4000	340	0.20
5	4800	480	0.30	3200	280	0.20
6	4000	400	0.30	2600	210	0.20
8	3000	300	0.30	2000	170	0.30
10	2400	240	0.30	1600	140	0.30
12	2000	200	0.30	1300	110	0.30

Depth of cut

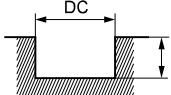

≤ Please refer to the list above for depth of cut.

DC: Dia.

■ Side milling

Work material	P					
	Carbon steel, Cast iron, Alloy steel (–30HRC) Cf53, GG25			Alloy steel, Tool steel, Pre-hardened steel X40CrMoV51		
Dia. DC (mm)	Revolution (min ⁻¹)	Feed rate (mm/min)	Depth of cut (mm)	Revolution (min ⁻¹)	Feed rate (mm/min)	Depth of cut (mm)
3	3500	370	0.05	2600	250	0.03
4	2800	370	0.06	2100	200	0.03
5	2200	330	0.06	1700	160	0.03
6	1800	300	0.06	1500	140	0.03
8	1600	270	0.08	1100	140	0.04
10	1400	240	0.10	900	140	0.05
12	1200	200	0.10	750	120	0.06

Depth of cut

≤ Please refer to the list above for depth of cut.

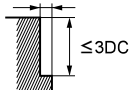

≤ 3DC

DC: Dia.

Note 1) If the depth of cut is shallow, the revolution and feed rate can be increased.

Note 2) When drilling, please set the feed rate at 1/3 or below the values above.

Note 3) If the rigidity of the machine or the work materials installation is very low, or chattering and noise are generated, reduce the revolution and feed rate proportionately.

MSTAR END MILLS

MSMHZD

End mill, Medium cut length, 3 flute

CARBIDE



Carbon Steel, Alloy Steel, Cast Iron (<30HRC)	Tool Steel, Pre-Hardened Steel, Hardened Steel (≤45HRC)	Hardened Steel (≤55HRC)	Hardened Steel (>55HRC)	Austenitic Stainless Steel	Titanium Alloy, Heat Resistant Alloy	Copper Alloy	Aluminium Alloy
○	○	○		○	○	○	

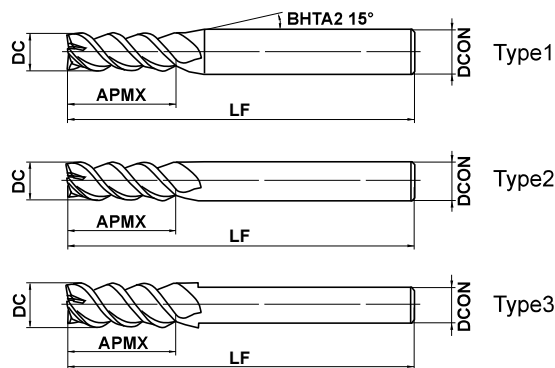

DC ≤ 12	DC > 12			
0 - 0.020	0 - 0.030			
4 ≤ DC ≤ 6	8 ≤ DC ≤ 10	12 ≤ DC ≤ 16	DC = 20	
0 - 0.008	0 - 0.009	0 - 0.011	0 - 0.013	



● 3 flute end mill for both plunging and slotting.

(mm)

Order Number	DC	APMX	LF	DOCN	Flutes	Stock	Type
MSMHZDD0100	1	2	45	4	3	●	1
MSMHZDD0150	1.5	3	45	4	3	●	1
MSMHZDD0200	2	4	50	6	3	●	1
MSMHZDD0250	2.5	5	50	6	3	●	1
MSMHZDD0300	3	6	50	6	3	●	1
MSMHZDD0350	3.5	8	50	6	3	●	1
MSMHZDD0400	4	8	50	6	3	●	1
MSMHZDD0450	4.5	10	50	6	3	●	1
MSMHZDD0500	5	10	50	6	3	●	1
MSMHZDD0550	5.5	13	50	6	3	●	1
MSMHZDD0600	6	13	60	6	3	●	2
MSMHZDD0650	6.5	16	60	8	3	●	1
MSMHZDD0700	7	16	60	8	3	●	1
MSMHZDD0750	7.5	16	60	8	3	●	1
MSMHZDD0800	8	19	70	8	3	●	2
MSMHZDD0850	8.5	19	70	10	3	●	1
MSMHZDD0900	9	19	70	10	3	●	1
MSMHZDD0950	9.5	19	70	10	3	●	1
MSMHZDD1000	10	22	80	10	3	●	2
MSMHZDD1100	11	22	80	12	3	●	1
MSMHZDD1200	12	26	90	12	3	●	2
MSMHZDD1300	13	26	90	12	3	●	3
MSMHZDD1400	14	26	90	12	3	●	3
MSMHZDD1500	15	26	110	16	3	●	1
MSMHZDD1600	16	30	110	16	3	●	2
MSMHZDD2000	20	32	140	20	3	●	2

● : Inventory maintained.

SOLID END MILLS

SQUARE

BALL

RADIUS

TAPER

BARREL

ROUGHING

RECOMMENDED CUTTING CONDITIONS

Side milling

Work material	P				M		S	
	Carbon steel, Cast iron, Alloy steel (-30HRC)		Alloy steel, Tool steel, Pre-hardened steel		Austenitic stainless steel, Titanium alloy		Heat resistant alloys	
	Cf53, GG25		X40CrMoV51		X5CrNi1810, X5CrNiMo17122, Ti6Al4V		Inconel718	
Dia. DC (mm)	Revolution (min ⁻¹)	Feed rate (mm/min)	Revolution (min ⁻¹)	Feed rate (mm/min)	Revolution (min ⁻¹)	Feed rate (mm/min)	Revolution (min ⁻¹)	Feed rate (mm/min)
1	19000	600	13000	310	10000	200	9500	65
1.5	14000	600	9000	310	7500	210	6400	75
2	11000	600	7200	310	6000	210	4800	75
3	8500	770	5300	380	4400	220	3200	100
4	7200	850	4400	480	3700	250	2400	130
6	5300	940	3200	490	2700	270	1600	130
8	4000	1010	2400	560	2000	280	1200	120
10	3200	1000	1900	480	1600	300	950	110
12	2700	950	1600	440	1300	300	800	90
16	2000	720	1200	350	1000	260	600	70
20	1600	600	1000	290	800	240	480	60

Depth of cut	$\leq 0.2DC$ ($DC > \phi 3$) $\leq 0.1DC$ ($DC \leq \phi 3$)		

DC: Dia.

Plunging

Work material	P				M		S	
	Carbon steel, Cast iron, Alloy steel (-30HRC)		Alloy steel, Tool steel, Pre-hardened steel		Austenitic stainless steel, Titanium alloy		Heat resistant alloys	
	Cf53, GG25		X40CrMoV51		X5CrNi1810, X5CrNiMo17122, Ti6Al4V		Inconel718	
Dia. DC (mm)	Revolution (min ⁻¹)	Feed rate (mm/min)	Revolution (min ⁻¹)	Feed rate (mm/min)	Revolution (min ⁻¹)	Feed rate (mm/min)	Revolution (min ⁻¹)	Feed rate (mm/min)
1	13000	80	10000	50	6000	10		
1.5	12000	120	8000	80	6000	20		
2	11000	200	7200	140	6000	30		
3	8500	250	5300	180	4200	50		
4	7200	300	4400	210	3300	60		
6	5300	300	3200	210	2200	70		
8	4000	320	2400	220	1600	80		
10	3200	340	1900	240	1300	70		
12	2700	320	1600	220	1100	70		
16	2000	250	1200	180	800	55		
20	1600	200	1000	140	640	55		

Depth of cut	$\leq 1DC$ ($DC \geq \phi 2$) $\leq 0.5DC$ ($DC < \phi 2$)		

DC: Dia.

Slotting

Work material	P				M		S	
	Carbon steel, Cast iron, Alloy steel (-30HRC)		Alloy steel, Tool steel, Pre-hardened steel		Austenitic stainless steel, Titanium alloy		Heat resistant alloys	
	Cf53, GG25		X40CrMoV51		X5CrNi1810, X5CrNiMo17122, Ti6Al4V		Inconel718	
Dia. DC (mm)	Revolution (min ⁻¹)	Feed rate (mm/min)	Revolution (min ⁻¹)	Feed rate (mm/min)	Revolution (min ⁻¹)	Feed rate (mm/min)	Revolution (min ⁻¹)	Feed rate (mm/min)
1	13000	130	10000	80	6000	30	5700	25
1.5	12000	250	8000	150	6000	60	3800	30
2	11000	500	7200	260	6000	130	2800	35
3	8500	640	5300	320	4200	130	1900	50
4	7200	650	4400	370	3300	140	1400	70
6	5300	720	3200	380	2200	140	950	70
8	4000	780	2400	430	1600	140	720	60
10	3200	770	1900	370	1300	150	570	50
12	2700	730	1600	340	1100	150	480	40
16	2000	600	1200	290	800	130	360	30
20	1600	500	1000	240	640	120	290	25

Depth of cut	$\leq 1DC$ ($DC \geq \phi 2$) $\leq 0.5DC$ ($DC < \phi 2$)		

DC: Dia.

Note 1) When cutting austenitic stainless steels, the use of water-soluble cutting fluid is effective.

Note 2) If the depth of cut is shallow, the revolution and feed rate can be increased.

Note 3) If the rigidity of the machine or the work materials installation is very low, or chattering and noise are generated, reduce the revolution and feed rate proportionately.

SOLID END MILLS

SQUARE

BALL

RADIUS

TAPER

BARREL

ROUGHING

MSTAR END MILLS

MS4SC

End mill, Short cut length, 4 flute



Carbon Steel, Alloy Steel, Cast Iron (<30HRC)	Tool Steel, Pre-Hardened Steel, Hardened Steel (≤45HRC)	Hardened Steel (≤55HRC)	Hardened Steel (>55HRC)	Austenitic Stainless Steel	Titanium Alloy, Heat Resistant Alloy	Copper Alloy	Aluminium Alloy
○	○	○		○	○	○	

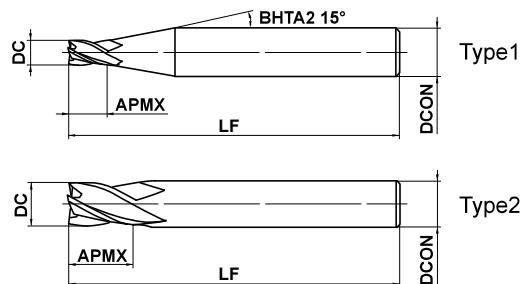

SOLID END MILLS



$1 \leq DC \leq 12$				
0				
-0.020				



$4 \leq DCON \leq 6$	$8 \leq DCON \leq 10$	$DCON = 12$		
0	0	0		
-0.008	-0.009	-0.011		

● 4 flute end mill for general use.

(mm)

Order Number	DC	APMX	LF	DCON	Flutes	Stock	Type
MS4SCD0100	1	1.5	40	4	4	●	1
MS4SCD0150	1.5	2.3	40	4	4	●	1
MS4SCD0200	2	3	40	4	4	●	1
MS4SCD0250	2.5	3.8	40	4	4	●	1
MS4SCD0300	3	4.5	50	6	4	●	1
MS4SCD0400	4	6	50	6	4	●	1
MS4SCD0500	5	7.5	50	6	4	●	1
MS4SCD0600	6	9	50	6	4	●	2
MS4SCD0800	8	12	60	8	4	●	2
MS4SCD1000	10	15	70	10	4	●	2
MS4SCD1200	12	18	75	12	4	●	2

SQUARE

BALL

RADIUS

TAPER

BARREL

ROUGHING

● : Inventory maintained.

MS4MC

End mill, Medium cut length, 4 flute



CARBIDE

Carbon Steel, Alloy Steel, Cast Iron (<30HRC)	Tool Steel, Pre-Hardened Steel, Hardened Steel (<=45HRC)	Hardened Steel (<=55HRC)	Hardened Steel (>55HRC)	Austenitic Stainless Steel	Titanium Alloy, Heat Resistant Alloy	Copper Alloy	Aluminium Alloy
○	○	○		○	○	○	

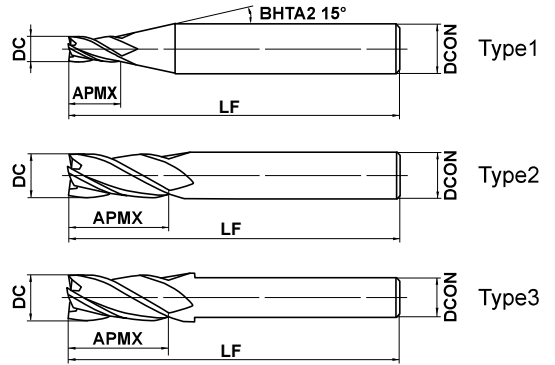

	DC ≤ 12	DC > 12			
	0 - 0.020	0 - 0.030			
	4 ≤ DCON ≤ 6	8 ≤ DCON ≤ 10	12 ≤ DCON ≤ 16	DCON = 20	
	0 - 0.008	0 - 0.009	0 - 0.011	0 - 0.013	

● 4 flute end mill for general use.

(mm)

Order Number	DC	APMX	LF	DCON	Flutes	Stock	Type
MS4MCD0100	1	2.5	40	4	4	●	1
MS4MCD0150	1.5	3.8	40	4	4	●	1
MS4MCD0200	2	5	40	4	4	●	1
MS4MCD0250	2.5	6.3	40	4	4	●	1
MS4MCD0300	3	7.5	50	6	4	●	1
MS4MCD0350	3.5	9	50	6	4	●	1
MS4MCD0400	4	10	50	6	4	●	1
MS4MCD0450	4.5	11.5	50	6	4	●	1
MS4MCD0500	5	12.5	50	6	4	●	1
MS4MCD0550	5.5	14	50	6	4	●	1
MS4MCD0600	6	15	50	6	4	●	2
MS4MCD0650	6.5	16.5	60	8	4	●	1
MS4MCD0700	7	17.5	60	8	4	●	1
MS4MCD0750	7.5	19	60	8	4	●	1
MS4MCD0800	8	20	60	8	4	●	2
MS4MCD0850	8.5	21.5	70	10	4	●	1
MS4MCD0900	9	22.5	70	10	4	●	1
MS4MCD0950	9.5	24	70	10	4	●	1
MS4MCD1000	10	25	70	10	4	●	2
MS4MCD1100	11	27.5	75	12	4	●	1
MS4MCD1200	12	30	90	12	4	●	2
MS4MCD1400	14	35	90	12	4	●	3
MS4MCD1600	16	40	100	16	4	●	2
MS4MCD1800	18	45	100	16	4	●	3
MS4MCD2000	20	50	110	20	4	●	2

SOLID END MILLS

SQUARE

BALL

RADIUS

TAPER

BARREL

ROUGHING

MSTAR END MILLS

MS4SC

End mill, Short cut length, 4 flute

MS4MC

End mill, Medium cut length, 4 flute

RECOMMENDED CUTTING CONDITIONS

Dia. DC (mm)	P			H		
	Revolution (min ⁻¹)	Feed rate (mm/min)	Depth of cut (mm)	Revolution (min ⁻¹)	Feed rate (mm/min)	Depth of cut (mm)
	Carbon steel, Cast iron, Alloy steel, Pre-hardened steel Cf53, GG25			Hardened steel (45—55HRC) X40CrMoV51		
1	40000	3000	0.06	32000	2400	0.06
1.5	40000	4500	0.12	32000	3600	0.08
2	30000	4500	0.18	24000	3600	0.10
2.5	24000	3900	0.25	19000	3000	0.13
3	20000	3500	0.30	16000	2700	0.15
4	15000	3000	0.40	12000	2400	0.20
5	12000	2400	0.50	9000	1800	0.25
6	10000	2100	0.60	7000	1500	0.30
8	8000	1500	0.80	5600	1100	0.40
10	6400	1400	1.00	4500	950	0.50
12	5400	1200	1.00	3800	860	0.50
16	2400	550	3.00	1200	120	0.80
20	1900	480	4.00	1000	100	1.00

Depth of cut

≤ Please refer to the list above for depth of cut.

≤ Please refer to the list above for depth of cut.

DC: Dia.

Note 1) If the depth of cut is shallow, the revolution and feed rate can be increased.

Note 2) When slotting with end mills of $\phi 3$ or larger, reduce the revolution by 30—50% and the feed rate by 40—60%.

Note 3) When drilling, please set the feed rate at 1/3 or below the values above.

Note 4) If the rigidity of the machine or the work materials installation is very low, or chattering and noise are generated, reduce the revolution and feed rate proportionately.

CARBIDE

SOLID END MILLS

SQUARE

BALL

RADIUS

TAPER

BARREL

ROUGHING

MS4JC

End mill, Semi long cut length, 4 flute



CARBIDE

Carbon Steel, Alloy Steel, Cast Iron (<30HRC)	Tool Steel, Pre-Hardened Steel, Hardened Steel (≤45HRC)	Hardened Steel (≤55HRC)	Hardened Steel (>55HRC)	Austenitic Stainless Steel	Titanium Alloy, Heat Resistant Alloy	Copper Alloy	Aluminium Alloy
○	○	○	○	○	○	○	○

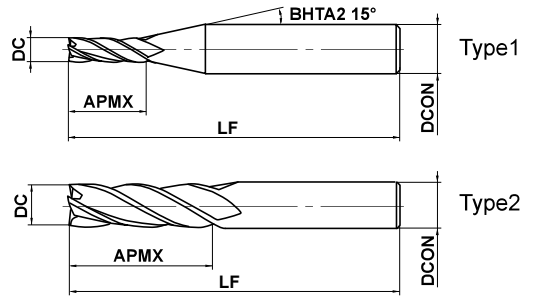

	1 ≤ DC ≤ 12				
	0 - 0.020				
	4 ≤ DCON ≤ 6	8 ≤ DCON ≤ 10	DCON = 12		
	0 - 0.008	0 - 0.009	0 - 0.011		

● 4 flute end mill for general use.

(mm)

Order Number	DC	APMX	LF	DCON	Flutes	Stock	Type
MS4JCD0100	1	4	40	4	4	●	1
MS4JCD0150	1.5	6	40	4	4	●	1
MS4JCD0200	2	8	40	4	4	●	1
MS4JCD0250	2.5	10	50	4	4	●	1
MS4JCD0300	3	12	50	6	4	●	1
MS4JCD0400	4	16	50	6	4	●	1
MS4JCD0500	5	20	60	6	4	●	1
MS4JCD0600	6	24	60	6	4	●	2
MS4JCD0800	8	32	70	8	4	●	2
MS4JCD1000	10	40	90	10	4	●	2
MS4JCD1200	12	48	110	12	4	●	2

SOLID END MILLS

SQUARE

BALL

RADIUS

TAPER

BARREL

ROUGHING

● : Inventory maintained.

MSTAR END MILLS

MS4JC

End mill, Semi long cut length, 4 flute

CARBIDE

RECOMMENDED CUTTING CONDITIONS

Work material	P				M	S	H	
	Carbon steel, Cast iron, Alloy steel (-30HRC) CF53, GG25		Alloy steel, Tool steel, Pre-hardened steel X40CrMoV51		Austenitic stainless steel, Titanium alloy X5CrNi1810, X5CrNiMo17122, Ti6Al4V	Hardened steel (45-55HRC) X40CrMoV51		
Dia. DC (mm)	Revolution (min ⁻¹)	Feed rate (mm/min)	Revolution (min ⁻¹)	Feed rate (mm/min)	Revolution (min ⁻¹)	Feed rate (mm/min)	Revolution (min ⁻¹)	Feed rate (mm/min)
1	11100	85	9500	65	8000	50	6400	35
1.5	7400	85	6400	90	5300	50	4200	35
2	5600	85	4800	90	4000	50	3200	35
2.5	4500	85	3800	90	3200	55	2500	35
3	3700	90	3400	90	2600	60	2100	35
4	3000	110	2700	90	2100	70	1700	50
5	2600	140	2300	110	1800	85	1500	55
6	2300	170	2000	140	1500	110	1300	70
8	1700	180	1500	140	1200	110	1000	70
10	1400	180	1300	140	950	110	800	70
12	1200	170	1100	140	800	110	670	70

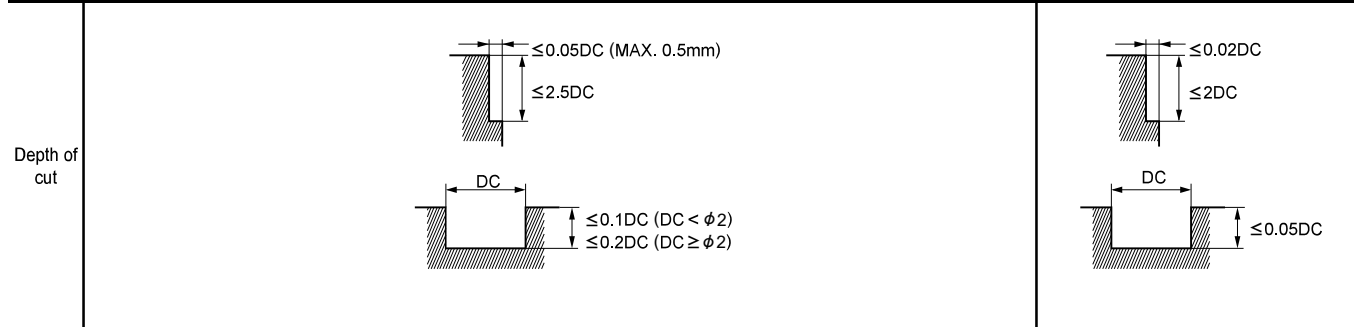

DC: Dia.

Note 1) When cutting austenitic stainless steels, the use of water-soluble cutting fluid is effective.

Note 2) If the depth of cut is shallow, the revolution and feed rate can be increased.

Note 3) When drilling, please set the feed rate at 1/3 or below the values above.

Note 4) If the rigidity of the machine or the work materials installation is very low, or chattering and noise are generated, reduce the revolution and feed rate proportionately.

SOLID END MILLS

SQUARE

BALL

RADIUS

TAPER

BARREL

ROUGHING

MSSHDD

High power, Short cut length, 4 flute



CARBIDE

Carbon Steel, Alloy Steel, Cast Iron (<30HRC)	Tool Steel, Pre-Hardened Steel, Hardened Steel (≤45HRC)	Hardened Steel (≤55HRC)	Hardened Steel (>55HRC)	Austenitic Stainless Steel	Titanium Alloy, Heat Resistant Alloy	Copper Alloy	Aluminium Alloy
○	○	○		○	○	○	

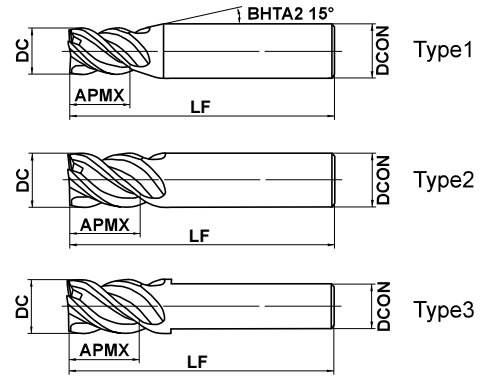

	DC ≤ 12	DC > 12			
	$\begin{matrix} 0 \\ -0.020 \end{matrix}$	$\begin{matrix} 0 \\ -0.030 \end{matrix}$			
	DCON = 6	8 ≤ DCON ≤ 10	12 ≤ DCON ≤ 16	DCON = 20	
	$\begin{matrix} 0 \\ -0.008 \end{matrix}$	$\begin{matrix} 0 \\ -0.009 \end{matrix}$	$\begin{matrix} 0 \\ -0.011 \end{matrix}$	$\begin{matrix} 0 \\ -0.013 \end{matrix}$	

● 4 flute high power end mill.

(mm)

Order Number	DC	APMX	LF	DCON	Flutes	Stock	Type
MSSHDD0300	3	4.5	45	6	4	●	1
MSSHDD0350	3.5	5.3	45	6	4	●	1
MSSHDD0400	4	6	45	6	4	●	1
MSSHDD0450	4.5	6.8	45	6	4	●	1
MSSHDD0500	5	7.5	50	6	4	●	1
MSSHDD0550	5.5	8.3	50	6	4	●	1
MSSHDD0600	6	9	50	6	4	●	2
MSSHDD0650	6.5	9.8	60	8	4	●	1
MSSHDD0700	7	10.5	60	8	4	●	1
MSSHDD0750	7.5	11.3	60	8	4	●	1
MSSHDD0800	8	12	60	8	4	●	2
MSSHDD0850	8.5	12.8	70	10	4	●	1
MSSHDD0900	9	13.5	70	10	4	●	1
MSSHDD0950	9.5	14.3	70	10	4	●	1
MSSHDD1000	10	15	70	10	4	●	2
MSSHDD1100	11	16.5	75	12	4	●	1
MSSHDD1200	12	18	75	12	4	●	2
MSSHDD1300	13	19.5	75	12	4	●	3
MSSHDD1400	14	21	90	16	4	●	1
MSSHDD1500	15	22.5	90	16	4	●	1
MSSHDD1600	16	24	90	16	4	●	2
MSSHDD1700	17	25.5	100	16	4	●	3
MSSHDD1800	18	27	100	16	4	●	3
MSSHDD1900	19	28.5	110	20	4	●	1
MSSHDD2000	20	30	110	20	4	●	2

● : Inventory maintained.

SOLID END MILLS

SQUARE

BALL

RADIUS

TAPER

BARREL

ROUGHING

MSTAR END MILLS

MSMHD

High power, Medium cut length, 4 flute



CARBIDE

Carbon Steel, Alloy Steel, Cast Iron (<30HRC)	Tool Steel, Pre-Hardened Steel, Hardened Steel (≤45HRC)	Hardened Steel (≤55HRC)	Hardened Steel (>55HRC)	Austenitic Stainless Steel	Titanium Alloy, Heat Resistant Alloy	Copper Alloy	Aluminium Alloy
○	○	○		○	○	○	

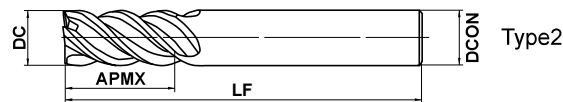
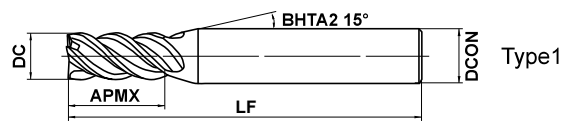

SOLID END MILLS



DC ≤ 12	DC > 12			
0 - 0.020	0 - 0.030			
4 ≤ DCON ≤ 6	8 ≤ DCON ≤ 10	12 ≤ DCON ≤ 16	20 ≤ DCON ≤ 25	
0 - 0.008	0 - 0.009	0 - 0.011	0 - 0.013	

● 4 flute high power end mill.

(mm)

Order Number	DC	APMX	LF	DCON	Flutes	Stock	Type
MSMHDD0200	2	4	45	4	4	●	1
MSMHDD0210	2.1	5	45	4	4	●	1
MSMHDD0220	2.2	5	45	4	4	●	1
MSMHDD0230	2.3	5	45	4	4	●	1
MSMHDD0240	2.4	5	45	4	4	●	1
MSMHDD0250	2.5	5	45	4	4	●	1
MSMHDD0260	2.6	6	45	4	4	●	1
MSMHDD0270	2.7	6	45	4	4	●	1
MSMHDD0280	2.8	6	45	4	4	●	1
MSMHDD0290	2.9	6	45	4	4	●	1
MSMHDD0300	3	8	45	6	4	●	1
MSMHDD0310	3.1	8	45	6	4	●	1
MSMHDD0320	3.2	8	45	6	4	●	1
MSMHDD0330	3.3	8	45	6	4	●	1
MSMHDD0340	3.4	8	45	6	4	●	1
MSMHDD0350	3.5	8	45	6	4	●	1
MSMHDD0360	3.6	11	45	6	4	●	1
MSMHDD0370	3.7	11	45	6	4	●	1
MSMHDD0380	3.8	11	45	6	4	●	1
MSMHDD0390	3.9	11	45	6	4	●	1
MSMHDD0400	4	11	45	6	4	●	1
MSMHDD0410	4.1	12	45	6	4	●	1
MSMHDD0420	4.2	12	45	6	4	●	1
MSMHDD0430	4.3	12	45	6	4	●	1
MSMHDD0440	4.4	12	45	6	4	●	1
MSMHDD0450	4.5	12	45	6	4	●	1
MSMHDD0460	4.6	13	50	6	4	●	1
MSMHDD0470	4.7	13	50	6	4	●	1
MSMHDD0480	4.8	13	50	6	4	●	1
MSMHDD0490	4.9	13	50	6	4	●	1
MSMHDD0500	5	13	50	6	4	●	1
MSMHDD0510	5.1	13	50	6	4	●	1
MSMHDD0520	5.2	13	50	6	4	●	1
MSMHDD0530	5.3	13	50	6	4	●	1

● : Inventory maintained.

SQUARE

BALL

RADIUS

TAPER

BARREL

ROUGHING

(mm)

Order Number	DC	APMX	LF	DCON	Flutes	Stock	Type
MSMHDD0540	5.4	13	50	6	4	●	1
MSMHDD0550	5.5	13	50	6	4	●	1
MSMHDD0560	5.6	13	50	6	4	●	1
MSMHDD0570	5.7	13	50	6	4	●	1
MSMHDD0580	5.8	13	50	6	4	●	1
MSMHDD0590	5.9	13	50	6	4	●	1
MSMHDD0600	6	13	50	6	4	●	2
MSMHDD0650	6.5	16	60	8	4	●	1
MSMHDD0700	7	19	60	8	4	●	1
MSMHDD0750	7.5	19	60	8	4	●	1
MSMHDD0800	8	19	60	8	4	●	2
MSMHDD0850	8.5	19	70	10	4	●	1
MSMHDD0900	9	22	70	10	4	●	1
MSMHDD0950	9.5	22	70	10	4	●	1
MSMHDD1000	10	22	70	10	4	●	2
MSMHDD1100	11	26	75	12	4	●	1
MSMHDD1200S10	12	26	75	10	4	●	3
MSMHDD1200	12	26	75	12	4	●	2
MSMHDD1300	13	26	75	12	4	●	3
MSMHDD1400	14	30	90	16	4	●	1
MSMHDD1500	15	35	90	16	4	●	1
MSMHDD1600	16	35	90	16	4	●	2
MSMHDD1700	17	35	100	16	4	●	3
MSMHDD1800	18	40	100	16	4	●	3
MSMHDD1900	19	40	110	20	4	●	1
MSMHDD2000	20	45	110	20	4	●	2
MSMHDD2200	22	50	125	20	4	●	3
MSMHDD2500	25	55	125	25	4	●	2

SOLID END MILLS

SQUARE

BALL

RADIUS

TAPER

BARREL

ROUGHING

MSTAR END MILLS

MSSH D

High power, Short cut length, 4 flute

MSMHD

High power, Medium cut length, 4 flute

RECOMMENDED CUTTING CONDITIONS

Side milling

Work material	P				M		S		H		S	
	Revolution (min ⁻¹)	Feed rate (mm/min)	Revolution (min ⁻¹)	Feed rate (mm/min)	Revolution (min ⁻¹)	Feed rate (mm/min)	Revolution (min ⁻¹)	Feed rate (mm/min)	Revolution (min ⁻¹)	Feed rate (mm/min)	Revolution (min ⁻¹)	Feed rate (mm/min)
Carbon steel, Cast iron, Alloy steel (–30HRC) Cf53, GG25			Alloy steel, Tool steel, Pre-hardened steel X40CrMoV51		Austenitic stainless steel, Titanium alloy X5CrNi1810, X5CrNiMo17122, Ti6Al4V		Hardened steel (45–55HRC) X40CrMoV51		Heat resistant alloys Inconel718			
Dia. DC (mm)												
2	15000	550	10000	340	10000	320	6400	160	4800	100		
3	11000	800	7400	500	7400	480	4800	250	4000	170		
4	8000	900	5600	540	5600	520	3600	270	3200	240		
5	6400	1000	4500	600	4500	580	2900	300	2600	240		
6	5800	1100	3700	640	3700	600	2400	320	2100	230		
8	4400	1100	2800	660	2800	600	1800	330	1600	220		
10	3500	1000	2200	640	2200	560	1400	320	1300	200		
12	2900	1000	1900	640	1900	530	1200	320	1100	170		
16	2200	800	1400	500	1400	450	900	250	800	130		
20	1800	750	1100	460	1100	440	720	230	640	100		
25	1400	600	900	400	900	380	570	200	510	80		
Depth of cut												

DC: Dia.

Slotting

Work material	P				M		S		H		S	
	Revolution (min ⁻¹)	Feed rate (mm/min)	Revolution (min ⁻¹)	Feed rate (mm/min)	Revolution (min ⁻¹)	Feed rate (mm/min)	Revolution (min ⁻¹)	Feed rate (mm/min)	Revolution (min ⁻¹)	Feed rate (mm/min)	Revolution (min ⁻¹)	Feed rate (mm/min)
Carbon steel, Cast iron, Alloy steel (–30HRC) Cf53, GG25			Alloy steel, Tool steel, Pre-hardened steel X40CrMoV51		Austenitic stainless steel, Titanium alloy X5CrNi1810, X5CrNiMo17122, Ti6Al4V		Hardened steel (45–55HRC) X40CrMoV51		Heat resistant alloys Inconel718			
Dia. DC (mm)												
2	12000	400	7000	200	7000	100	4200	80	2300	40		
3	9000	600	5300	300	5300	150	3200	130	1900	70		
4	7200	720	4000	360	4000	180	2400	140	1400	95		
5	5800	720	3200	360	3200	180	1900	150	1100	95		
6	5000	800	2700	400	2700	200	1600	160	950	95		
8	3700	800	2000	400	2000	200	1200	170	720	90		
10	3000	720	1600	360	1600	180	960	160	570	80		
12	2500	720	1300	360	1300	180	800	160	480	70		
16	2000	600	1000	280	1000	150	600	130	360	50		
20	1600	540	800	250	800	130	480	120	290	40		
25	1300	480	640	220	640	120	380	100	230	35		
Depth of cut												

DC: Dia.

Note 1) When cutting austenitic stainless steels, the use of water-soluble cutting fluid is effective.

Note 2) If the depth of cut is shallow, the revolution and feed rate can be increased.

Note 3) If the rigidity of the machine or the work materials installation is very low, or chattering and noise are generated, reduce the revolution and feed rate proportionately.

MS2ES

End mill, For small automatic lathes, 2 flute



CARBIDE

Carbon Steel, Alloy Steel, Cast Iron (<30HRC)	Tool Steel, Pre-Hardened Steel, Hardened Steel (≤45HRC)	Hardened Steel (≤55HRC)	Hardened Steel (>55HRC)	Austenitic Stainless Steel	Titanium Alloy, Heat Resistant Alloy	Copper Alloy	Aluminium Alloy
○	○	○	○	○	○	○	○

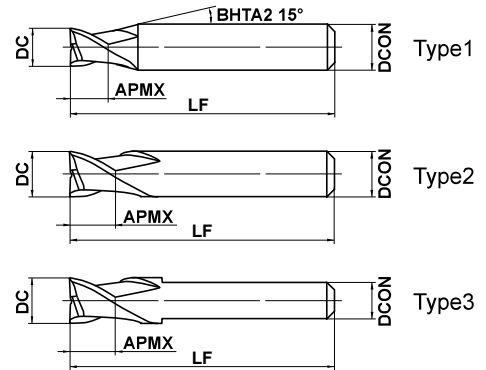

	3 ≤ DC ≤ 12				
	0 - 0.020				
	4 ≤ DCON ≤ 6	7 ≤ DCON ≤ 10			
	0 - 0.008	0 - 0.009			

● 2 flute end mill.

Overall length 35mm

(mm)

Order Number	DC	APMX	LF	DCON	Flutes	Stock	Type
MS2ESD0300L35S04	3	3	35	4	2	●	1
MS2ESD0350L35S04	3.5	3.5	35	4	2	●	1
MS2ESD0400L35S04	4	4	35	4	2	●	2
MS2ESD0500L35S05	5	5	35	5	2	●	2
MS2ESD0500L35S06	5	5	35	6	2	●	1
MS2ESD0600L35S05	6	6	35	5	2	●	3
MS2ESD0600L35S06	6	6	35	6	2	●	2
MS2ESD0700L35S07	7	6	35	7	2	●	2
MS2ESD0800L35S07	8	6	35	7	2	●	3
MS2ESD0800L35S08	8	6	35	8	2	●	2
MS2ESD1000L35S07	10	6	35	7	2	●	3
MS2ESD1000L35S10	10	6	35	10	2	●	2
MS2ESD1200L35S10	12	6	35	10	2	●	3

Overall length 45mm

(mm)

Order Number	DC	APMX	LF	DCON	Flutes	Stock	Type
MS2ESD0300L45S04	3	3	45	4	2	●	1
MS2ESD0350L45S04	3.5	3.5	45	4	2	●	1
MS2ESD0400L45S04	4	4	45	4	2	●	2
MS2ESD0500L45S06	5	5	45	6	2	●	1
MS2ESD0600L45S06	6	6	45	6	2	●	2
MS2ESD0700L45S07	7	7	45	7	2	●	2
MS2ESD0800L45S07	8	8	45	7	2	●	3
MS2ESD0800L45S08	8	8	45	8	2	●	2
MS2ESD1000L45S07	10	10	45	7	2	●	3
MS2ESD1000L45S10	10	10	45	10	2	●	2
MS2ESD1200L45S10	12	12	45	10	2	●	3

● : Inventory maintained.

SOLID END MILLS

SQUARE

BALL

RADIUS

TAPER

BARREL

ROUGHING

MSTAR END MILLS

MS3ES

End mill, For small automatic lathes, 3 flute



Carbon Steel, Alloy Steel, Cast Iron (<30HRC)	Tool Steel, Pre-Hardened Steel, Hardened Steel (≤45HRC)	Hardened Steel (≤55HRC)	Hardened Steel (>55HRC)	Austenitic Stainless Steel	Titanium Alloy, Heat Resistant Alloy	Copper Alloy	Aluminium Alloy
○	○	○		○	○	○	

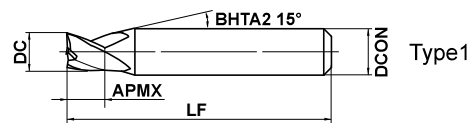

SOLID END MILLS



$3 \leq DC \leq 12$				
0				
-0.020				



$4 \leq DCON \leq 6$	$7 \leq DCON \leq 10$			
0	0			
-0.008	-0.009			

● 3 flute end mill.

Overall length 35mm

(mm)

Order Number	DC	APMX	LF	DCON	Flutes	Stock	Type
MS3ESD0300L35S04	3	3	35	4	3	●	1
MS3ESD0350L35S04	3.5	3.5	35	4	3	●	1
MS3ESD0400L35S04	4	4	35	4	3	●	2
MS3ESD0500L35S05	5	5	35	5	3	★	2
MS3ESD0500L35S06	5	5	35	6	3	●	1
MS3ESD0600L35S05	6	6	35	5	3	★	3
MS3ESD0600L35S06	6	6	35	6	3	●	2
MS3ESD0700L35S07	7	6	35	7	3	★	2
MS3ESD0800L35S07	8	6	35	7	3	★	3
MS3ESD0800L35S08	8	6	35	8	3	●	2
MS3ESD1000L35S07	10	6	35	7	3	★	3
MS3ESD1000L35S10	10	6	35	10	3	●	2
MS3ESD1200L35S10	12	6	35	10	3	●	3

Overall length 45mm

(mm)

Order Number	DC	APMX	LF	DCON	Flutes	Stock	Type
MS3ESD0300L45S04	3	3	45	4	3	●	1
MS3ESD0350L45S04	3.5	3.5	45	4	3	●	1
MS3ESD0400L45S04	4	4	45	4	3	●	2
MS3ESD0500L45S06	5	5	45	6	3	●	1
MS3ESD0600L45S06	6	6	45	6	3	●	2
MS3ESD0700L45S07	7	7	45	7	3	★	2
MS3ESD0800L45S07	8	8	45	7	3	★	3
MS3ESD0800L45S08	8	8	45	8	3	●	2
MS3ESD1000L45S07	10	10	45	7	3	★	3
MS3ESD1000L45S10	10	10	45	10	3	●	2
MS3ESD1200L45S10	12	12	45	10	3	●	3

● : Inventory maintained. ★ : Inventory maintained in Japan.

SQUARE

BALL

RADIUS

TAPER

BARREL

ROUGHING

MS2ES

End mill, For small automatic lathes, 2 flute

MS3ES

End mill, For small automatic lathe, 3 flute

CARBIDE

RECOMMENDED CUTTING CONDITIONS

Work material	P				M	S	H	
	Carbon steel, Cast iron, Alloy steel (—30HRC) Cf53, GG25		Alloy steel, Tool steel, Pre-hardened steel X40CrMoV51		Austenitic stainless steel, Titanium alloy X5CrNi1810, X5CrNiMo17122, Ti6Al4V		Hardened steel (45—55HRC) X40CrMoV51	
Dia. DC (mm)	Revolution (min ⁻¹)	Feed rate (mm/min)	Revolution (min ⁻¹)	Feed rate (mm/min)	Revolution (min ⁻¹)	Feed rate (mm/min)	Revolution (min ⁻¹)	Feed rate (mm/min)
3	10000	600	7000	400	6000	300	5000	120
4	7500	600	5200	400	4500	300	4000	120
5	6000	600	4200	400	3600	300	3200	120
6	5000	600	3500	400	3000	300	2700	120
7	4500	560	3000	360	2700	280	2300	110
8	4000	520	2800	350	2400	260	2000	110
10	3200	450	2200	300	1900	230	1600	100
12	2700	410	1900	270	1600	210	1300	100

Depth of cut	P		M	S	H
	DC	DC	DC	DC	DC

DC: Dia.

Note 1) When cutting austenitic stainless steels, the use of water-soluble cutting fluid is effective.

Note 2) If the depth of cut is shallow, the revolution and feed rate can be increased.

Note 3) When drilling, please set the feed rate at 1/3 or below the values above.

Note 4) If the rigidity of the machine or the work materials installation is very low, or chattering and noise are generated, reduce the revolution and feed rate proportionately.

SOLID END MILLS

SQUARE

BALL

RADIUS

TAPER

BARREL

ROUGHING

MSTAR END MILLS

MS4EC

End mill, For small automatic lathes, 4 flute



Carbon Steel, Alloy Steel, Cast Iron (<30HRC)	Tool Steel, Pre-Hardened Steel, Hardened Steel (≤45HRC)	Hardened Steel (≤55HRC)	Hardened Steel (>55HRC)	Austenitic Stainless Steel	Titanium Alloy, Heat Resistant Alloy	Copper Alloy	Aluminium Alloy
○	○	○		○	○	○	

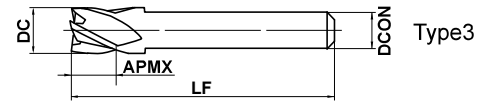
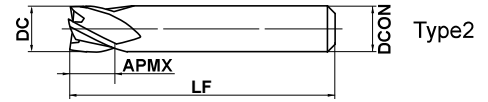
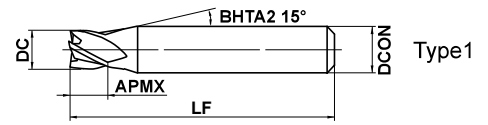

	DC ≤ 12	DC > 12			
	0 - 0.020	0 - 0.030			
	4 ≤ DCON ≤ 6	7 ≤ DCON ≤ 10			
	0 - 0.008	0 - 0.009			

● 4 flute end mill.

Overall length 35mm

(mm)

Order Number	DC	APMX	LF	DCON	Flutes	Stock	Type
MS4ECD0300L35S04	3	3	35	4	4	●	1
MS4ECD0350L35S04	3.5	3.5	35	4	4	●	1
MS4ECD0400L35S04	4	4	35	4	4	●	2
MS4ECD0500L35S05	5	5	35	5	4	★	2
MS4ECD0500L35S06	5	5	35	6	4	●	1
MS4ECD0600L35S05	6	6	35	5	4	★	3
MS4ECD0600L35S06	6	6	35	6	4	●	2
MS4ECD0700L35S07	7	6	35	7	4	★	2
MS4ECD0800L35S07	8	6	35	7	4	★	3
MS4ECD0800L35S08	8	6	35	8	4	●	2
MS4ECD1000L35S07	10	6	35	7	4	★	3
MS4ECD1000L35S10	10	6	35	10	4	●	2
MS4ECD1200L35S10	12	6	35	10	4	●	3

Overall length 45mm

(mm)

Order Number	DC	APMX	LF	DCON	Flutes	Stock	Type
MS4ECD0300L45S04	3	3	45	4	4	●	1
MS4ECD0350L45S04	3.5	3.5	45	4	4	●	1
MS4ECD0400L45S04	4	4	45	4	4	●	2
MS4ECD0500L45S06	5	5	45	6	4	●	1
MS4ECD0600L45S06	6	6	45	6	4	●	2
MS4ECD0700L45S07	7	7	45	7	4	★	2
MS4ECD0800L45S07	8	8	45	7	4	★	3
MS4ECD0800L45S08	8	8	45	8	4	●	2
MS4ECD1000L45S07	10	10	45	7	4	★	3
MS4ECD1000L45S10	10	10	45	10	4	●	2
MS4ECD1200L45S10	12	12	45	10	4	●	3
MS4ECD1400L45S10	14	14	45	10	4	●	3

● : Inventory maintained. ★ : Inventory maintained in Japan.

RECOMMENDED CUTTING CONDITIONS

Work material	P				M	S	H	
	Carbon steel, Cast iron, Alloy steel (—30HRC) Cf53, GG25		Alloy steel, Tool steel, Pre-hardened steel X40CrMoV51		Austenitic stainless steel, Titanium alloy X5CrNi1810, X5CrNiMo17122, Ti6Al4V	Hardened steel (45—55HRC) X40CrMoV51		
Dia. DC (mm)	Revolution (min ⁻¹)	Feed rate (mm/min)	Revolution (min ⁻¹)	Feed rate (mm/min)	Revolution (min ⁻¹)	Feed rate (mm/min)	Revolution (min ⁻¹)	Feed rate (mm/min)
3	10000	900	7000	600	6000	450	5000	180
4	7500	900	5200	600	4500	450	4000	180
5	6000	900	4200	600	3600	450	3200	180
6	5000	900	3500	600	3000	450	2700	180
7	4500	840	3000	540	2700	420	2300	160
8	4000	780	2800	520	2400	390	2000	160
10	3200	680	2200	450	1900	340	1600	140
12	2700	620	1900	410	1600	310	1300	120
14	2300	550	1600	350	1400	280	1200	120

Depth of cut	P		M		S		H	
	DC	≤1DC	DC	≤0.2DC	DC	≤0.05DC	DC	≤0.1DC

DC: Dia.

Note 1) When cutting austenitic stainless steels, the use of water-soluble cutting fluid is effective.

Note 2) If the depth of cut is shallow, the revolution and feed rate can be increased.

Note 3) When drilling, please set the feed rate at 1/3 or below the values above.

Note 4) If the rigidity of the machine or the work materials installation is very low, or chattering and noise are generated, reduce the revolution and feed rate proportionately.

MSTAR END MILLS

MS2XL

End mill, Short cut length, Long neck, 2 flute



DC<0.4 DC≥0.4

Carbon Steel, Alloy Steel, Cast Iron (<30HRC)	Tool Steel, Pre-Hardened Steel, Hardened Steel (≤45HRC)	Hardened Steel (≤55HRC)	Hardened Steel (>55HRC)	Austenitic Stainless Steel	Titanium Alloy, Heat Resistant Alloy	Copper Alloy	Aluminium Alloy
○	○	○	○	○	○	○	○

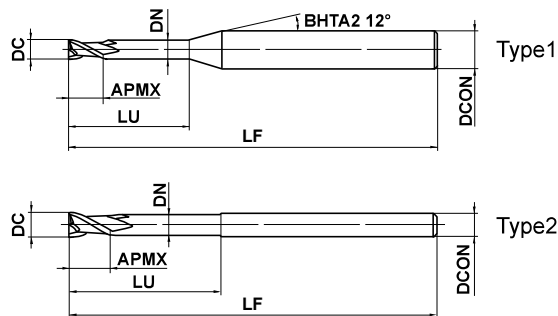

SOLID END MILLS



DC<0.5	DC≥0.5			
0 - 0.010	0 - 0.020			
4 ≤ DCON ≤ 6				
h6 0 - 0.008				

● 2 flute long neck end mill.

(mm)

Order Number	DC	APMX	LU	DN	LF	DCON	Flutes	Stock	Type
MS2XLD0020N005	0.2	0.3	0.5	0.17	45	4	2	●	1
MS2XLD0020N010	0.2	0.3	1	0.17	45	4	2	●	1
MS2XLD0020N015	0.2	0.3	1.5	0.17	45	4	2	●	1
MS2XLD0030N010	0.3	0.4	1	0.27	45	4	2	●	1
MS2XLD0030N020	0.3	0.4	2	0.27	45	4	2	●	1
MS2XLD0030N030	0.3	0.4	3	0.27	45	4	2	●	1
MS2XLD0030N060	0.3	0.4	6	0.27	45	4	2	●	1
MS2XLD0030N090	0.3	0.4	9	0.27	45	4	2	●	1
MS2XLD0040N020	0.4	0.6	2	0.36	45	4	2	●	1
MS2XLD0040N030	0.4	0.6	3	0.36	45	4	2	●	1
MS2XLD0040N040	0.4	0.6	4	0.36	45	4	2	●	1
MS2XLD0040N080	0.4	0.6	8	0.36	45	4	2	●	1
MS2XLD0040N120	0.4	0.6	12	0.36	45	4	2	●	1
MS2XLD0050N020	0.5	0.7	2	0.46	45	4	2	●	1
MS2XLD0050N040	0.5	0.7	4	0.46	45	4	2	●	1
MS2XLD0050N060	0.5	0.7	6	0.46	45	4	2	●	1
MS2XLD0050N080	0.5	0.7	8	0.46	50	4	2	●	1
MS2XLD0050N100	0.5	0.7	10	0.46	50	4	2	●	1
MS2XLD0050N150	0.5	0.7	15	0.46	50	4	2	●	1
MS2XLD0060N020	0.6	0.9	2	0.56	45	4	2	●	1
MS2XLD0060N040	0.6	0.9	4	0.56	45	4	2	●	1
MS2XLD0060N060	0.6	0.9	6	0.56	45	4	2	●	1
MS2XLD0060N080	0.6	0.9	8	0.56	50	4	2	●	1
MS2XLD0060N100	0.6	0.9	10	0.56	50	4	2	●	1
MS2XLD0060N120	0.6	0.9	12	0.56	50	4	2	●	1
MS2XLD0060N180	0.6	0.9	18	0.56	50	4	2	●	1
MS2XLD0070N020	0.7	1	2	0.66	45	4	2	●	1
MS2XLD0070N040	0.7	1	4	0.66	45	4	2	●	1
MS2XLD0070N060	0.7	1	6	0.66	45	4	2	●	1
MS2XLD0070N080	0.7	1	8	0.66	50	4	2	●	1
MS2XLD0070N100	0.7	1	10	0.66	50	4	2	●	1
MS2XLD0080N040	0.8	1.2	4	0.76	45	4	2	●	1
MS2XLD0080N060	0.8	1.2	6	0.76	45	4	2	●	1
MS2XLD0080N080	0.8	1.2	8	0.76	50	4	2	●	1

● : Inventory maintained.

(mm)

Order Number	DC	APMX	LU	DN	LF	DCON	Flutes	Stock	Type
MS2XLD0080N100	0.8	1.2	10	0.76	50	4	2	●	1
MS2XLD0080N120	0.8	1.2	12	0.76	50	4	2	●	1
MS2XLD0080N160	0.8	1.2	16	0.76	50	4	2	●	1
MS2XLD0080N240	0.8	1.2	24	0.76	60	4	2	●	1
MS2XLD0090N060	0.9	1.4	6	0.86	45	4	2	●	1
MS2XLD0090N080	0.9	1.4	8	0.86	50	4	2	●	1
MS2XLD0090N100	0.9	1.4	10	0.86	50	4	2	●	1
MS2XLD0090N150	0.9	1.4	15	0.86	60	4	2	●	1
MS2XLD0100N040	1	1.5	4	0.94	50	4	2	●	1
MS2XLD0100N060	1	1.5	6	0.94	50	4	2	●	1
MS2XLD0100N080	1	1.5	8	0.94	50	4	2	●	1
MS2XLD0100N100	1	1.5	10	0.94	50	4	2	●	1
MS2XLD0100N120	1	1.5	12	0.94	50	4	2	●	1
MS2XLD0100N160	1	1.5	16	0.94	60	4	2	●	1
MS2XLD0100N200	1	1.5	20	0.94	60	4	2	●	1
MS2XLD0100N250	1	1.5	25	0.94	70	4	2	●	1
MS2XLD0100N300	1	1.5	30	0.94	70	4	2	●	1
MS2XLD0120N060	1.2	1.8	6	1.14	50	4	2	●	1
MS2XLD0120N080	1.2	1.8	8	1.14	50	4	2	●	1
MS2XLD0120N100	1.2	1.8	10	1.14	50	4	2	●	1
MS2XLD0120N120	1.2	1.8	12	1.14	50	4	2	●	1
MS2XLD0120N160	1.2	1.8	16	1.14	60	4	2	●	1
MS2XLD0120N200	1.2	1.8	20	1.14	60	4	2	●	1
MS2XLD0150N060	1.5	2.3	6	1.44	50	4	2	●	1
MS2XLD0150N080	1.5	2.3	8	1.44	50	4	2	●	1
MS2XLD0150N100	1.5	2.3	10	1.44	50	4	2	●	1
MS2XLD0150N120	1.5	2.3	12	1.44	50	4	2	●	1
MS2XLD0150N140	1.5	2.3	14	1.44	60	4	2	●	1
MS2XLD0150N160	1.5	2.3	16	1.44	60	4	2	●	1
MS2XLD0150N180	1.5	2.3	18	1.44	60	4	2	●	1
MS2XLD0150N200	1.5	2.3	20	1.44	60	4	2	●	1
MS2XLD0150N250	1.5	2.3	25	1.44	70	4	2	●	1
MS2XLD0150N300	1.5	2.3	30	1.44	70	4	2	●	1
MS2XLD0150N380	1.5	2.3	38	1.44	80	4	2	●	1
MS2XLD0150N450	1.5	2.3	45	1.44	80	4	2	●	1
MS2XLD0200N060	2	3	6	1.9	50	4	2	●	1
MS2XLD0200N080	2	3	8	1.9	50	4	2	●	1
MS2XLD0200N100	2	3	10	1.9	50	4	2	●	1
MS2XLD0200N120	2	3	12	1.9	50	4	2	●	1
MS2XLD0200N140	2	3	14	1.9	60	4	2	●	1
MS2XLD0200N160	2	3	16	1.9	60	4	2	●	1
MS2XLD0200N180	2	3	18	1.9	60	4	2	●	1
MS2XLD0200N200	2	3	20	1.9	60	4	2	●	1
MS2XLD0200N250	2	3	25	1.9	70	4	2	●	1
MS2XLD0200N300	2	3	30	1.9	70	4	2	●	1
MS2XLD0200N350	2	3	35	1.9	80	4	2	●	1
MS2XLD0200N400	2	3	40	1.9	90	4	2	●	1
MS2XLD0200N500	2	3	50	1.9	100	4	2	●	1
MS2XLD0200N600	2	3	60	1.9	110	4	2	●	1
MS2XLD0250N080	2.5	3.7	8	2.4	50	4	2	●	1
MS2XLD0250N120	2.5	3.7	12	2.4	50	4	2	●	1
MS2XLD0250N160	2.5	3.7	16	2.4	60	4	2	●	1

SOLID END MILLS

SQUARE

BALL

RADIUS

TAPER

BARREL

ROUGHING

MSTAR END MILLS

MS2XL

End mill, Short cut length, Long neck, 2 flute

(mm)

Order Number	DC	APMX	LU	DN	LF	DCON	Flutes	Stock	Type
MS2XLD0250N200	2.5	3.7	20	2.4	60	4	2	●	1
MS2XLD0250N250	2.5	3.7	25	2.4	70	4	2	●	1
MS2XLD0250N300	2.5	3.7	30	2.4	70	4	2	●	1
MS2XLD0250N400	2.5	3.7	40	2.4	90	4	2	●	1
MS2XLD0250N500	2.5	3.7	50	2.4	100	4	2	●	1
MS2XLD0300N080	3	4.5	8	2.8	50	6	2	●	1
MS2XLD0300N120	3	4.5	12	2.8	50	6	2	●	1
MS2XLD0300N160	3	4.5	16	2.8	60	6	2	●	1
MS2XLD0300N200	3	4.5	20	2.8	60	6	2	●	1
MS2XLD0300N250	3	4.5	25	2.8	70	6	2	●	1
MS2XLD0300N300	3	4.5	30	2.8	70	6	2	●	1
MS2XLD0300N400	3	4.5	40	2.8	90	6	2	●	1
MS2XLD0300N500	3	4.5	50	2.8	100	6	2	●	1
MS2XLD0400N120	4	6	12	3.8	50	6	2	●	1
MS2XLD0400N160	4	6	16	3.8	60	6	2	●	1
MS2XLD0400N200	4	6	20	3.8	60	6	2	●	1
MS2XLD0400N250	4	6	25	3.8	70	6	2	●	1
MS2XLD0400N300	4	6	30	3.8	70	6	2	●	1
MS2XLD0400N350	4	6	35	3.8	80	6	2	●	1
MS2XLD0400N400	4	6	40	3.8	90	6	2	●	1
MS2XLD0400N450	4	6	45	3.8	90	6	2	●	1
MS2XLD0400N500	4	6	50	3.8	100	6	2	●	1
MS2XLD0400N600	4	6	60	3.8	110	6	2	●	1
MS2XLD0500N160	5	7.5	16	4.8	60	6	2	●	1
MS2XLD0500N250	5	7.5	25	4.8	70	6	2	●	1
MS2XLD0500N350	5	7.5	35	4.8	80	6	2	●	1
MS2XLD0500N500	5	7.5	50	4.8	110	6	2	●	1
MS2XLD0500N600	5	7.5	60	4.8	120	6	2	●	1
MS2XLD0600N200	6	9	20	5.8	80	6	2	●	2
MS2XLD0600N300	6	9	30	5.8	90	6	2	●	2
MS2XLD0600N400	6	9	40	5.8	100	6	2	●	2
MS2XLD0600N500	6	9	50	5.8	110	6	2	●	2
MS2XLD0600N600	6	9	60	5.8	120	6	2	●	2

● : Inventory maintained.

CARBIDE

SOLID END MILLS

SQUARE

BALL

RADIUS

TAPER

BARREL

ROUGHING

RECOMMENDED CUTTING CONDITIONS

Work material		P		
		Carbon steel, Cast iron, Alloy steel, Pre-hardened steel Cf53, GG25		
Dia. DC (mm)	Neck length LU (mm)	Revolution (min ⁻¹)	Feed rate (mm/min)	Depth of cut ap (mm)
0.2	0.5	40000	600	0.004
	1	40000	400	0.001
0.3	1	40000	650	0.007
	3	40000	500	0.002
	9	22000	150	0.001
0.4	2	40000	800	0.007
	4	40000	800	0.003
	12	17000	150	0.001
0.5	2	40000	950	0.01
	6	40000	700	0.003
	10	25000	400	0.002
	15	14000	150	0.001
0.6	2	40000	950	0.01
	6	40000	800	0.005
	10	25000	450	0.003
	18	12000	150	0.001
0.7	2	40000	1000	0.02
	6	40000	900	0.01
	8	30000	700	0.005
	10	11000	300	0.005
0.8	4	40000	1200	0.02
	8	40000	1000	0.01
	12	25000	400	0.003
	24	10000	150	0.001
0.9	6	40000	1300	0.02
	10	35000	1000	0.01
	15	9000	400	0.003
1	6	40000	1600	0.04
	8	40000	1600	0.03
	12	30000	1000	0.02
	20	15000	400	0.005
	30	8000	150	0.001
1.2	6	40000	1900	0.06
	8	40000	1900	0.04
	12	25000	1000	0.03
	20	6500	150	0.01

Depth of cut

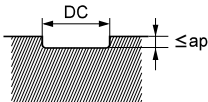

DC: Dia.

Depth of cut

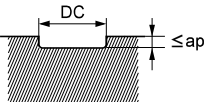

DC: Dia.

Note 1) If the depth of cut is shallow, the revolution and feed rate can be increased.

Note 2) Cutting conditions may be considerably different due to the overhang (milling depth), depth of cut, and machine tool. Please see the above table as a standard.

Work material		P		
		Carbon steel, Cast iron, Alloy steel, Pre-hardened steel Cf53, GG25		
Dia. DC (mm)	Neck length LU (mm)	Revolution (min ⁻¹)	Feed rate (mm/min)	Depth of cut ap (mm)
1.5	6	40000	2400	0.10
	10	30000	1800	0.05
	20	15000	600	0.02
	30	7500	300	0.005
	45	5000	150	0.001
1.6	6	40000	2400	0.12
	10	30000	1800	0.07
	16	20000	1000	0.04
2	6	40000	2400	0.18
	10	30000	1800	0.10
	16	20000	1000	0.06
	30	8000	500	0.04
	40	6000	250	0.01
	60	4200	150	0.003
2.5	8	25000	2500	0.20
	16	18000	1700	0.10
	20	12000	1000	0.08
	40	8000	400	0.03
3	8	25000	2500	0.20
	16	18000	1700	0.10
	20	12000	1000	0.08
	40	8000	400	0.03
4	8	20000	2000	0.30
	16	15000	1400	0.15
	20	10000	800	0.10
	40	5000	250	0.02
	50	3700	150	0.010
5	12	15000	3000	0.30
	20	11000	2200	0.22
	30	6400	1200	0.12
	40	4500	400	0.05
	50	2800	150	0.018
6	16	12000	2500	0.35
	35	5100	750	0.15
	60	2200	150	0.02
6	20	10000	2000	0.40
	40	4200	800	0.20
	60	1900	150	0.10

Depth of cut

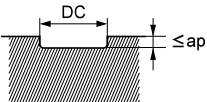

DC: Dia.

Depth of cut

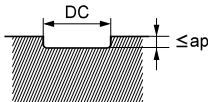

DC: Dia.

SOLID END MILLS

SQUARE

BALL

RADIUS

TAPER

BARREL

ROUGHING

MSTAR END MILLS

MS2XL6

End mill, Short cut length, 6mm shank, 2 flute



Carbon Steel, Alloy Steel, Cast Iron (<30HRC)	Tool Steel, Pre-Hardened Steel, Hardened Steel (≤45HRC)	Hardened Steel (≤55HRC)	Hardened Steel (>55HRC)	Austenitic Stainless Steel	Titanium Alloy, Heat Resistant Alloy	Copper Alloy	Aluminium Alloy
○	○	○		○	○	○	

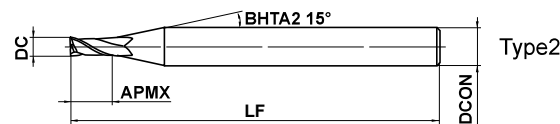
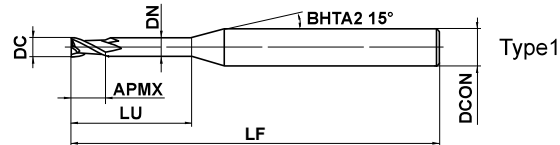

SOLID END MILLS



0.3 ≤ DC ≤ 2.5				
0 - 0.020				
DCON=6				
h6 0 - 0.008				



● 2 flute long neck end mill.

● φ6 shank type.

(mm)

Order Number	DC	APMX	LU	DN	LF	DCON	Flutes	Stock	Type
MS2XL6D0030N008	0.3	0.8	—	—	50	6	2	★	2
MS2XL6D0030N015	0.3	0.5	1.5	0.27	50	6	2	●	1
MS2XL6D0040N010	0.4	0.6	1	0.36	50	6	2	★	1
MS2XL6D0040N020	0.4	0.6	2	0.36	50	6	2	●	1
MS2XL6D0050N013	0.5	0.8	1.3	0.46	50	6	2	●	1
MS2XL6D0050N025	0.5	0.8	2.5	0.46	50	6	2	●	1
MS2XL6D0060N015	0.6	0.9	1.5	0.56	50	6	2	★	1
MS2XL6D0060N030	0.6	0.9	3	0.56	50	6	2	●	1
MS2XL6D0070N018	0.7	1.1	1.8	0.66	50	6	2	★	1
MS2XL6D0070N035	0.7	1.1	3.5	0.66	50	6	2	●	1
MS2XL6D0080N020	0.8	1.2	2	0.76	50	6	2	★	1
MS2XL6D0080N040	0.8	1.2	4	0.76	50	6	2	●	1
MS2XL6D0090N023	0.9	1.4	2.3	0.86	50	6	2	★	1
MS2XL6D0090N045	0.9	1.4	4.5	0.86	50	6	2	●	1
MS2XL6D0100N025	1	1.5	2.5	0.94	50	6	2	●	1
MS2XL6D0100N050	1	1.5	5	0.94	50	6	2	●	1
MS2XL6D0110N028	1.1	1.7	2.8	1.04	50	6	2	★	1
MS2XL6D0110N055	1.1	1.7	5.5	1.04	50	6	2	●	1
MS2XL6D0120N030	1.2	1.8	3	1.14	50	6	2	★	1
MS2XL6D0120N060	1.2	1.8	6	1.14	50	6	2	●	1
MS2XL6D0130N033	1.3	2	3.3	1.24	50	6	2	●	1
MS2XL6D0130N065	1.3	2	6.5	1.24	50	6	2	●	1
MS2XL6D0140N035	1.4	2.1	3.5	1.34	50	6	2	●	1
MS2XL6D0140N070	1.4	2.1	7	1.34	50	6	2	●	1
MS2XL6D0150N038	1.5	2.3	3.8	1.44	50	6	2	●	1
MS2XL6D0150N075	1.5	2.3	7.5	1.44	50	6	2	●	1
MS2XL6D0160N040	1.6	2.4	4	1.54	50	6	2	★	1
MS2XL6D0160N080	1.6	2.4	8	1.54	50	6	2	●	1
MS2XL6D0170N043	1.7	2.6	4.3	1.64	50	6	2	★	1
MS2XL6D0170N085	1.7	2.6	8.5	1.64	50	6	2	●	1
MS2XL6D0180N045	1.8	2.7	4.5	1.74	50	6	2	★	1
MS2XL6D0180N090	1.8	2.7	9	1.74	50	6	2	●	1
MS2XL6D0190N048	1.9	2.9	4.8	1.84	50	6	2	★	1
MS2XL6D0190N095	1.9	2.9	9.5	1.84	50	6	2	●	1

● : Inventory maintained. ★ : Inventory maintained in Japan.

(mm)

Order Number	DC	APMX	LU	DN	LF	DCON	Flutes	Stock	Type
MS2XL6D0200N050	2	3	5	1.90	50	6	2	●	1
MS2XL6D0200N100	2	3	10	1.90	50	6	2	●	1
MS2XL6D0210N053	2.1	3.2	5.3	2.00	50	6	2	★	1
MS2XL6D0210N105	2.1	3.2	10.5	2.00	60	6	2	●	1
MS2XL6D0220N055	2.2	3.3	5.5	2.10	50	6	2	★	1
MS2XL6D0220N110	2.2	3.3	11	2.10	60	6	2	●	1
MS2XL6D0230N058	2.3	3.5	5.8	2.20	50	6	2	★	1
MS2XL6D0230N115	2.3	3.5	11.5	2.20	60	6	2	●	1
MS2XL6D0240N060	2.4	3.6	6	2.30	50	6	2	★	1
MS2XL6D0240N120	2.4	3.6	12	2.30	60	6	2	●	1
MS2XL6D0250N063	2.5	3.8	6.3	2.40	50	6	2	●	1
MS2XL6D0250N125	2.5	3.8	12.5	2.40	60	6	2	●	1

SOLID END MILLS

SQUARE

BALL

RADIUS

TAPER

BARREL

ROUGHING

MSTAR END MILLS

MS2XL6

End mill, Short cut length, 6mm shank, 2 flute

CARBIDE

SOLID END MILLS

SQUARE

BALL

RADIUS

TAPER

BARREL

ROUGHING

RECOMMENDED CUTTING CONDITIONS

Work material		P					
		Carbon steel, Cast iron, Alloy steel (-30HRC) Cf53, GG25			Alloy steel, Tool steel, Pre-hardened steel X40CrMoV51		
Dia. DC (mm)	Neck length LU (mm)	Revolution (min ⁻¹)	Feed rate (mm/min)	Depth of cut ap (mm)	Revolution (min ⁻¹)	Feed rate (mm/min)	Depth of cut ap (mm)
0.3	—	40000	500—1000	0.01	30000	300—800	0.01
	1.5			0.007			0.007
0.4	1	40000	500—1000	0.015	30000	300—800	0.015
	2			0.01			0.01
0.5	1.3	40000	500—1000	0.02	30000	300—800	0.02
	2.5			0.013			0.013
0.6	1.5	33000	500—1000	0.03	25000	300—800	0.03
	3			0.018			0.018
0.7	1.8	29000	500—1000	0.04	22000	300—800	0.04
	3.5			0.025			0.025
0.8	2	25000	500—1000	0.06	20000	300—800	0.06
	4			0.03			0.03
0.9	2.3	22000	500—1000	0.08	18000	300—800	0.08
	4.5			0.05			0.05
1	2.5	20000	500—1000	0.1	16000	300—800	0.1
	5			0.07			0.07
1.1	2.8	18000	500—1000	0.12	14000	300—800	0.12
	5.5			0.08			0.08
1.2	3	16000	500—1000	0.12	13000	300—800	0.12
	6			0.08			0.08
1.3	3.3	15000	500—1000	0.12	12000	300—800	0.12
	6.5			0.08			0.08
1.4	3.5	14000	500—1000	0.12	11000	300—800	0.12
	7			0.08			0.08
1.5	3.8	13000	500—1000	0.15	10000	300—800	0.15
	7.5			0.1			0.1
1.6	4	12000	500—1000	0.15	10000	300—800	0.15
	8			0.1			0.1
1.7	4.3	12000	500—1000	0.17	9500	300—800	0.17
	8.5			0.12			0.12
1.8	4.5	11000	500—1000	0.17	9000	300—800	0.17
	9			0.12			0.12
1.9	4.8	10000	500—1000	0.17	9000	300—800	0.17
	9.5			0.12			0.12
2	5	10000	500—1000	0.2	9000	300—800	0.2
	10			0.15			0.15
2.1	5.3	9800	500—1000	0.2	9000	300—800	0.2
	10.5			0.15			0.15
2.2	5.5	9600	500—1000	0.2	9000	300—800	0.2
	11			0.15			0.15
2.3	5.8	9400	500—1000	0.2	8800	300—800	0.2
	11.5			0.15			0.15
2.4	6	9200	500—1000	0.25	8700	300—800	0.25
	12			0.2			0.2
2.5	6.3	9000	500—1000	0.25	8500	300—800	0.25
	12.5			0.2			0.2

Depth of cut

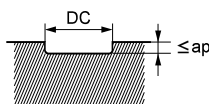

DC:Dia.

Note 1) If the depth of cut is shallow, the revolution and feed rate can be increased.

Note 2) Cutting conditions may be considerably different due to the overhang (milling depth), depth of cut, and machine tool. Please see the above table as a standard.

MS4XL

End mill, Long neck, 4 flute



CARBIDE

Carbon Steel, Alloy Steel, Cast Iron (<30HRC)	Tool Steel, Pre-Hardened Steel, Hardened Steel (≤45HRC)	Hardened Steel (≤55HRC)	Hardened Steel (>55HRC)	Austenitic Stainless Steel	Titanium Alloy, Heat Resistant Alloy	Copper Alloy	Aluminium Alloy
○	○	○	○	○	○	○	○

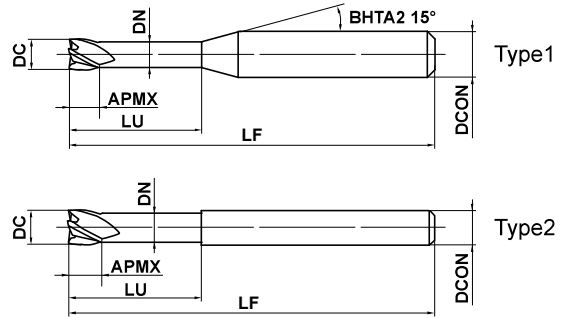

	1 ≤ DC ≤ 10			
	0 - 0.020			
	4 ≤ DCON ≤ 6	8 ≤ DCON ≤ 10		
	0 - 0.008	0 - 0.009		

● 4 flute long neck end mill.

(mm)

Order Number	DC	APMX	LU	DN	LF	DCON	Flutes	Stock	Type
MS4XLD0100N040	1	1	4	0.94	50	4	4	★	1
MS4XLD0100N060	1	1	6	0.94	50	4	4	●	1
MS4XLD0100N080	1	1	8	0.94	50	4	4	●	1
MS4XLD0100N100	1	1	10	0.94	50	4	4	●	1
MS4XLD0100N120	1	1	12	0.94	50	4	4	●	1
MS4XLD0100N160	1	1	16	0.94	60	4	4	●	1
MS4XLD0110N060	1.1	1.1	6	1.04	50	4	4	★	1
MS4XLD0110N100	1.1	1.1	10	1.04	50	4	4	★	1
MS4XLD0110N160	1.1	1.1	16	1.04	60	4	4	★	1
MS4XLD0120N060	1.2	1.2	6	1.14	50	4	4	★	1
MS4XLD0120N080	1.2	1.2	8	1.14	50	4	4	★	1
MS4XLD0120N100	1.2	1.2	10	1.14	50	4	4	★	1
MS4XLD0120N120	1.2	1.2	12	1.14	50	4	4	★	1
MS4XLD0120N160	1.2	1.2	16	1.14	60	4	4	★	1
MS4XLD0130N060	1.3	1.3	6	1.24	50	4	4	★	1
MS4XLD0130N120	1.3	1.3	12	1.24	50	4	4	★	1
MS4XLD0130N180	1.3	1.3	18	1.24	60	4	4	★	1
MS4XLD0140N060	1.4	1.4	6	1.34	50	4	4	★	1
MS4XLD0140N080	1.4	1.4	8	1.34	50	4	4	★	1
MS4XLD0140N100	1.4	1.4	10	1.34	50	4	4	★	1
MS4XLD0140N120	1.4	1.4	12	1.34	50	4	4	★	1
MS4XLD0140N140	1.4	1.4	14	1.34	60	4	4	★	1
MS4XLD0140N160	1.4	1.4	16	1.34	60	4	4	★	1
MS4XLD0140N220	1.4	1.4	22	1.34	60	4	4	★	1
MS4XLD0150N060	1.5	1.5	6	1.44	50	4	4	●	1
MS4XLD0150N080	1.5	1.5	8	1.44	50	4	4	●	1
MS4XLD0150N100	1.5	1.5	10	1.44	50	4	4	●	1
MS4XLD0150N120	1.5	1.5	12	1.44	50	4	4	●	1
MS4XLD0150N140	1.5	1.5	14	1.44	60	4	4	●	1
MS4XLD0150N160	1.5	1.5	16	1.44	60	4	4	●	1
MS4XLD0150N180	1.5	1.5	18	1.44	60	4	4	★	1
MS4XLD0150N200	1.5	1.5	20	1.44	60	4	4	★	1
MS4XLD0160N060	1.6	1.6	6	1.54	50	4	4	★	1
MS4XLD0160N080	1.6	1.6	8	1.54	50	4	4	★	1

● : Inventory maintained. ★ : Inventory maintained in Japan.

SOLID END MILLS

SQUARE

BALL

RADIUS

TAPER

BARREL

ROUGHING

MSTAR END MILLS

MS4XL

End mill, 4 flute, Long neck

(mm)

CARBIDE

—

SOLID END MILLS

SQUARE

BALL

RADIUS

TAPER

BARREL

ROUGHING

Order Number	DC	APMX	LU	DN	LF	DCON	Flutes	Stock	Type
MS4XLD0160N100	1.6	1.6	10	1.54	50	4	4	★	1
MS4XLD0160N120	1.6	1.6	12	1.54	50	4	4	★	1
MS4XLD0160N140	1.6	1.6	14	1.54	60	4	4	★	1
MS4XLD0160N160	1.6	1.6	16	1.54	60	4	4	★	1
MS4XLD0160N180	1.6	1.6	18	1.54	60	4	4	★	1
MS4XLD0160N200	1.6	1.6	20	1.54	60	4	4	★	1
MS4XLD0160N260	1.6	1.6	26	1.54	70	4	4	★	1
MS4XLD0170N060	1.7	1.7	6	1.64	50	4	4	★	1
MS4XLD0170N140	1.7	1.7	14	1.64	60	4	4	★	1
MS4XLD0170N240	1.7	1.7	24	1.64	70	4	4	★	1
MS4XLD0180N060	1.8	1.8	6	1.74	50	4	4	★	1
MS4XLD0180N080	1.8	1.8	8	1.74	50	4	4	★	1
MS4XLD0180N100	1.8	1.8	10	1.74	50	4	4	★	1
MS4XLD0180N120	1.8	1.8	12	1.74	50	4	4	★	1
MS4XLD0180N140	1.8	1.8	14	1.74	60	4	4	★	1
MS4XLD0180N160	1.8	1.8	16	1.74	60	4	4	★	1
MS4XLD0180N180	1.8	1.8	18	1.74	60	4	4	★	1
MS4XLD0180N200	1.8	1.8	20	1.74	60	4	4	★	1
MS4XLD0180N250	1.8	1.8	25	1.74	70	4	4	★	1
MS4XLD0190N060	1.9	1.9	6	1.84	50	4	4	★	1
MS4XLD0190N160	1.9	1.9	16	1.84	60	4	4	★	1
MS4XLD0190N280	1.9	1.9	28	1.84	70	4	4	★	1
MS4XLD0200N060	2	2	6	1.9	50	4	4	●	1
MS4XLD0200N080	2	2	8	1.9	50	4	4	●	1
MS4XLD0200N100	2	2	10	1.9	50	4	4	●	1
MS4XLD0200N120	2	2	12	1.9	50	4	4	●	1
MS4XLD0200N140	2	2	14	1.9	60	4	4	★	1
MS4XLD0200N160	2	2	16	1.9	60	4	4	●	1
MS4XLD0200N180	2	2	18	1.9	60	4	4	★	1
MS4XLD0200N200	2	2	20	1.9	60	4	4	●	1
MS4XLD0200N250	2	2	25	1.9	70	4	4	★	1
MS4XLD0200N300	2	2	30	1.9	70	4	4	●	1
MS4XLD0250N080	2.5	2.5	8	2.4	50	4	4	★	1
MS4XLD0250N120	2.5	2.5	12	2.4	50	4	4	★	1
MS4XLD0250N160	2.5	2.5	16	2.4	60	4	4	★	1
MS4XLD0250N200	2.5	2.5	20	2.4	60	4	4	★	1
MS4XLD0250N250	2.5	2.5	25	2.4	70	4	4	★	1
MS4XLD0300N080	3	3	8	2.9	50	6	4	●	1
MS4XLD0300N120	3	3	12	2.9	50	6	4	●	1
MS4XLD0300N160	3	3	16	2.9	60	6	4	●	1
MS4XLD0300N200	3	3	20	2.9	60	6	4	●	1
MS4XLD0300N250	3	3	25	2.9	70	6	4	●	1
MS4XLD0300N300	3	3	30	2.9	70	6	4	●	1
MS4XLD0350N150	3.5	3.5	15	3.4	60	6	4	●	1
MS4XLD0350N250	3.5	3.5	25	3.4	70	6	4	●	1
MS4XLD0350N350	3.5	3.5	35	3.4	80	6	4	●	1
MS4XLD0400N120	4	4	12	3.9	50	6	4	●	1
MS4XLD0400N160	4	4	16	3.9	60	6	4	●	1
MS4XLD0400N200	4	4	20	3.9	60	6	4	●	1
MS4XLD0400N250	4	4	25	3.9	70	6	4	●	1
MS4XLD0400N300	4	4	30	3.9	70	6	4	●	1
MS4XLD0400N350	4	4	35	3.9	80	6	4	●	1

● : Inventory maintained. ★ : Inventory maintained in Japan.

(mm)

Order Number	DC	APMX	LU	DN	LF	DCON	Flutes	Stock	Type
MS4XLD0400N400	4	4	40	3.9	90	6	4	●	1
MS4XLD0400N450	4	4	45	3.9	90	6	4	●	1
MS4XLD0400N500	4	4	50	3.9	100	6	4	●	1
MS4XLD0500N160	5	5	16	4.9	60	6	4	●	1
MS4XLD0500N250	5	5	25	4.9	70	6	4	●	1
MS4XLD0500N350	5	5	35	4.9	80	6	4	●	1
MS4XLD0500N500	5	5	50	4.9	110	6	4	●	1
MS4XLD0600N200	6	6	20	5.85	80	6	4	●	2
MS4XLD0600N300	6	6	30	5.85	90	6	4	●	2
MS4XLD0600N400	6	6	40	5.85	100	6	4	●	2
MS4XLD0600N500	6	6	50	5.85	110	6	4	●	2
MS4XLD0800N300	8	8	30	7.85	90	8	4	●	2
MS4XLD0800N500	8	8	50	7.85	110	8	4	●	2
MS4XLD0800N700	8	8	70	7.85	130	8	4	●	2
MS4XLD1000N400	10	10	40	9.7	100	10	4	●	2
MS4XLD1000N600	10	10	60	9.7	120	10	4	●	2
MS4XLD1000N800	10	10	80	9.7	140	10	4	●	2

SOLID END MILLS

SQUARE

BALL

RADIUS

TAPER

BARREL

ROUGHING

MSTAR END MILLS

MS4XL

End mill, 4 flute, Long neck

CARBIDE

RECOMMENDED CUTTING CONDITIONS

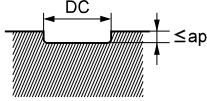
		P					P		
Work material		Carbon steel, Cast iron, Alloy steel, Pre-hardened steel Cf53, GG25			Work material		Carbon steel, Cast iron, Alloy steel, Pre-hardened steel Cf53, GG25		
Dia. DC (mm)	Neck length LU (mm)	Revolution (min ⁻¹)	Feed rate (mm/min)	Depth of cut ap (mm)	Dia. DC (mm)	Neck length LU (mm)	Revolution (min ⁻¹)	Feed rate (mm/min)	Depth of cut ap (mm)
1	4	40000	3000	0.04	3.5	15	20000	3000	0.6
	8	36000	2400	0.03		25	11000	1600	0.15
	12	20000	1000	0.02		35	5500	800	0.06
	16	10000	500	0.005					
1.2	6	40000	3000	0.05	4	12	18000	3000	1
	10	36000	2400	0.04		20	12000	2000	0.5
	12	20000	1200	0.03		30	8000	1300	0.2
	16	12000	600	0.01		40	4200	700	0.08
				50		2400	400	0.03	
1.5	6	40000	3200	0.06	5	16	14000	2700	1
	12	32000	2400	0.05		25	9500	1800	0.5
	16	16000	1100	0.03		35	6400	1200	0.2
	20	10000	600	0.01		50	3200	600	0.05
1.8	6	40000	3600	0.08	6	20	11000	2200	1.2
	12	32000	2800	0.06		30	8000	1600	0.6
	20	12000	1000	0.02		40	5400	1100	0.25
	25	7000	600	0.01		50	3200	640	0.15
2	6	40000	4000	0.1	8	30	8000	1600	1.6
	12	32000	3200	0.07		50	4000	800	0.5
	16	24000	2400	0.05		70	2000	400	0.2
	20	12000	1200	0.03		10	40	6400	1300
	30	5000	500	0.01	60		3200	640	0.6
2.5	8	32000	4000	0.2	80	1600	320	0.3	
	25	9000	1100	0.04					
	50	2500	300	0.005					
3	8	25000	3600	0.4	Depth of cut 				
	16	18000	2500	0.2					
	25	12000	1700	0.1					
	30	7000	800	0.05					

DC: Dia.
ap: Depth of Cut in the Axial Direction

Note 1) If the depth of cut is shallow, the revolution and feed rate can be increased.

Note 2) Cutting conditions may be considerably different due to the overhang (milling depth), depth of cut, and machine tool. Please see the above table as a standard.

MS2MRB

Corner radius end mill, Medium cut length, 2 flute



CARBIDE

Carbon Steel, Alloy Steel, Cast Iron (<30HRC)	Tool Steel, Pre-Hardened Steel, Hardened Steel (≤45HRC)	Hardened Steel (≤55HRC)	Hardened Steel (>55HRC)	Austenitic Stainless Steel	Titanium Alloy, Heat Resistant Alloy	Copper Alloy	Aluminium Alloy
○	○	○	○	○	○	○	○

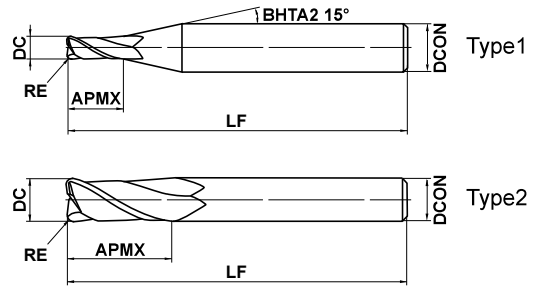

	1 ≤ DC ≤ 12				
	⁰ / _{-0.020}				
	4 ≤ DCON ≤ 6	8 ≤ DCON ≤ 10	DCON = 12		
	⁰ / _{-0.008}	⁰ / _{-0.009}	⁰ / _{-0.011}		

● 2 flute corner radius end mill for general use.

Order Number	DC	RE	APMX	LF	DCON	Flutes	Stock	Type
MS2MRBD0100R010	1	0.1	2	40	4	2	●	1
MS2MRBD0100R020	1	0.2	2	40	4	2	●	1
MS2MRBD0100R030	1	0.3	2	40	4	2	●	1
MS2MRBD0150R010	1.5	0.1	3	40	4	2	●	1
MS2MRBD0150R020	1.5	0.2	3	40	4	2	●	1
MS2MRBD0150R030	1.5	0.3	3	40	4	2	●	1
MS2MRBD0150R050	1.5	0.5	3	40	4	2	●	1
MS2MRBD0200R010	2	0.1	4	40	4	2	●	1
MS2MRBD0200R020	2	0.2	4	40	4	2	●	1
MS2MRBD0200R030	2	0.3	4	40	4	2	●	1
MS2MRBD0200R050	2	0.5	4	40	4	2	●	1
MS2MRBD0250R010	2.5	0.1	5	40	4	2	●	1
MS2MRBD0250R020	2.5	0.2	5	40	4	2	●	1
MS2MRBD0250R030	2.5	0.3	5	40	4	2	●	1
MS2MRBD0250R050	2.5	0.5	5	40	4	2	●	1
MS2MRBD0300R010	3	0.1	6	50	6	2	●	1
MS2MRBD0300R020	3	0.2	6	50	6	2	●	1
MS2MRBD0300R030	3	0.3	6	50	6	2	●	1
MS2MRBD0300R050	3	0.5	6	50	6	2	●	1
MS2MRBD0300R100	3	1	6	50	6	2	●	1
MS2MRBD0400R010	4	0.1	8	50	6	2	●	1
MS2MRBD0400R020	4	0.2	8	50	6	2	●	1
MS2MRBD0400R030	4	0.3	8	50	6	2	●	1
MS2MRBD0400R050	4	0.5	8	50	6	2	●	1
MS2MRBD0400R100	4	1	8	50	6	2	●	1
MS2MRBD0500R010	5	0.1	10	50	6	2	●	1
MS2MRBD0500R020	5	0.2	10	50	6	2	●	1
MS2MRBD0500R030	5	0.3	10	50	6	2	●	1
MS2MRBD0500R050	5	0.5	10	50	6	2	●	1
MS2MRBD0500R100	5	1	10	50	6	2	●	1
MS2MRBD0600R010	6	0.1	12	50	6	2	●	2
MS2MRBD0600R020	6	0.2	12	50	6	2	●	2
MS2MRBD0600R030	6	0.3	12	50	6	2	●	2
MS2MRBD0600R050	6	0.5	12	50	6	2	●	2

● : Inventory maintained.

SOLID END MILLS

SQUARE

BALL

RADIUS

TAPER

BARREL

ROUGHING

MSTAR END MILLS

MS2MRB

Corner radius end mill, Medium cut length, 2 flute

(mm)

Order Number	DC	RE	APMX	LF	DCON	Flutes	Stock	Type
MS2MRBD0600R100	6	1	12	50	6	2	●	2
MS2MRBD0600R150	6	1.5	12	50	6	2	●	2
MS2MRBD0600R200	6	2	12	50	6	2	●	2
MS2MRBD0800R020	8	0.2	16	60	8	2	●	2
MS2MRBD0800R030	8	0.3	16	60	8	2	●	2
MS2MRBD0800R050	8	0.5	16	60	8	2	●	2
MS2MRBD0800R100	8	1	16	60	8	2	●	2
MS2MRBD0800R150	8	1.5	16	60	8	2	●	2
MS2MRBD0800R200	8	2	16	60	8	2	●	2
MS2MRBD0800R250	8	2.5	16	60	8	2	●	2
MS2MRBD0800R300	8	3	16	60	8	2	●	2
MS2MRBD1000R020	10	0.2	20	70	10	2	●	2
MS2MRBD1000R030	10	0.3	20	70	10	2	●	2
MS2MRBD1000R050	10	0.5	20	70	10	2	●	2
MS2MRBD1000R100	10	1	20	70	10	2	●	2
MS2MRBD1000R150	10	1.5	20	70	10	2	●	2
MS2MRBD1000R200	10	2	20	70	10	2	●	2
MS2MRBD1000R250	10	2.5	20	70	10	2	●	2
MS2MRBD1000R300	10	3	20	70	10	2	●	2
MS2MRBD1200R020	12	0.2	24	75	12	2	●	2
MS2MRBD1200R030	12	0.3	24	75	12	2	●	2
MS2MRBD1200R050	12	0.5	24	75	12	2	●	2
MS2MRBD1200R100	12	1	24	75	12	2	●	2
MS2MRBD1200R150	12	1.5	24	75	12	2	●	2
MS2MRBD1200R200	12	2	24	75	12	2	●	2
MS2MRBD1200R250	12	2.5	24	75	12	2	●	2
MS2MRBD1200R300	12	3	24	75	12	2	●	2

- CARBIDE
- SOLID END MILLS
- SQUARE
- BALL
- RADIUS
- TAPER
- BARREL
- ROUGHING

● : Inventory maintained.

RECOMMENDED CUTTING CONDITIONS

Work material	P			H		
	Carbon steel, Cast iron, Alloy steel, Pre-hardened steel Cf53, GG25			Hardened steel (45—55HRC) X40CrMoV51		
Dia. DC (mm)	Revolution (min ⁻¹)	Feed rate (mm/min)	Depth of cut (mm)	Revolution (min ⁻¹)	Feed rate (mm/min)	Depth of cut (mm)
1	40000	2000	0.06	32000	1600	0.06
1.5	40000	3000	0.12	32000	1900	0.08
2	30000	3000	0.18	24000	1900	0.10
2.5	24000	2600	0.25	19000	1600	0.13
3	20000	2300	0.30	16000	1400	0.15
4	15000	2000	0.40	12000	1200	0.20
5	12000	1600	0.50	9000	900	0.25
6	10000	1400	0.60	7000	700	0.30
8	8000	1000	0.80	5600	550	0.40
10	6400	900	1.00	4500	500	0.50
12	5400	820	1.00	3800	450	0.50

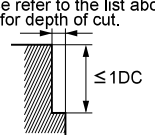
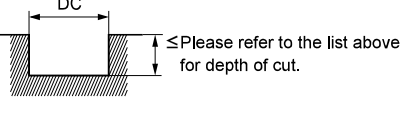
Depth of cut		
	DC: Dia.	

Note 1) If the depth of cut is shallow, the revolution and feed rate can be increased.

Note 2) When slotting with end mills of $\phi 3$ or larger, reduce the revolution by 30—50% and the feed rate by 40—60%.

Note 3) When drilling, please set the feed rate at 1/3 or below the values above.

Note 4) If the rigidity of the machine or the work materials installation is very low, or chattering and noise are generated, reduce the revolution and feed rate proportionately.

MSTAR END MILLS

MS4MRB

Corner radius end mill, Medium cut length, 4 flute



CARBIDE

Carbon Steel, Alloy Steel, Cast Iron (<30HRC)	Tool Steel, Pre-Hardened Steel, Hardened Steel (≤45HRC)	Hardened Steel (≤55HRC)	Hardened Steel (>55HRC)	Austenitic Stainless Steel	Titanium Alloy, Heat Resistant Alloy	Copper Alloy	Aluminium Alloy
○	○	○	○	○	○	○	○

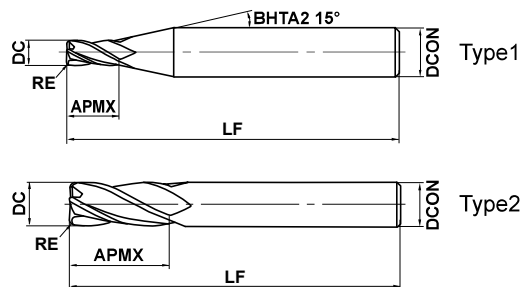

SOLID END MILLS



DC ≤ 12	DC > 12			
0 - 0.020	0 - 0.030			
DCON=6	8 ≤ DCON ≤ 10	12 ≤ DCON ≤ 16	DCON=20	
0 - 0.008	0 - 0.009	0 - 0.011	0 - 0.013	

● 4 flute corner radius end mill for general use.

(mm)

Order Number	DC	RE	APMX	LF	DCON	Flutes	Stock	Type
MS4MRBD0300R010	3	0.1	8	45	6	4	●	1
MS4MRBD0300R020	3	0.2	8	45	6	4	●	1
MS4MRBD0300R030	3	0.3	8	45	6	4	●	1
MS4MRBD0300R050	3	0.5	8	45	6	4	●	1
MS4MRBD0300R100	3	1	8	45	6	4	●	1
MS4MRBD0400R010	4	0.1	11	45	6	4	●	1
MS4MRBD0400R020	4	0.2	11	45	6	4	●	1
MS4MRBD0400R030	4	0.3	11	45	6	4	●	1
MS4MRBD0400R050	4	0.5	11	45	6	4	●	1
MS4MRBD0400R100	4	1	11	45	6	4	●	1
MS4MRBD0500R010	5	0.1	13	50	6	4	●	1
MS4MRBD0500R020	5	0.2	13	50	6	4	●	1
MS4MRBD0500R030	5	0.3	13	50	6	4	●	1
MS4MRBD0500R050	5	0.5	13	50	6	4	●	1
MS4MRBD0500R100	5	1	13	50	6	4	●	1
MS4MRBD0600R010	6	0.1	13	50	6	4	●	2
MS4MRBD0600R020	6	0.2	13	50	6	4	●	2
MS4MRBD0600R030	6	0.3	13	50	6	4	●	2
MS4MRBD0600R050	6	0.5	13	50	6	4	●	2
MS4MRBD0600R100	6	1	13	50	6	4	●	2
MS4MRBD0600R150	6	1.5	13	50	6	4	●	2
MS4MRBD0600R200	6	2	13	50	6	4	●	2
MS4MRBD0800R020	8	0.2	19	60	8	4	●	2
MS4MRBD0800R030	8	0.3	19	60	8	4	●	2
MS4MRBD0800R050	8	0.5	19	60	8	4	●	2
MS4MRBD0800R100	8	1	19	60	8	4	●	2
MS4MRBD0800R150	8	1.5	19	60	8	4	●	2
MS4MRBD0800R200	8	2	19	60	8	4	●	2
MS4MRBD0800R250	8	2.5	19	60	8	4	●	2
MS4MRBD0800R300	8	3	19	60	8	4	●	2
MS4MRBD1000R020	10	0.2	22	70	10	4	●	2
MS4MRBD1000R030	10	0.3	22	70	10	4	●	2
MS4MRBD1000R050	10	0.5	22	70	10	4	●	2
MS4MRBD1000R100	10	1	22	70	10	4	●	2

● : Inventory maintained.

(mm)

Order Number	DC	RE	APMX	LF	DCON	Flutes	Stock	Type
MS4MRBD1000R150	10	1.5	22	70	10	4	●	2
MS4MRBD1000R200	10	2	22	70	10	4	●	2
MS4MRBD1000R250	10	2.5	22	70	10	4	●	2
MS4MRBD1000R300	10	3	22	70	10	4	●	2
MS4MRBD1200R020	12	0.2	26	75	12	4	●	2
MS4MRBD1200R030	12	0.3	26	75	12	4	●	2
MS4MRBD1200R050	12	0.5	26	75	12	4	●	2
MS4MRBD1200R100	12	1	26	75	12	4	●	2
MS4MRBD1200R150	12	1.5	26	75	12	4	●	2
MS4MRBD1200R200	12	2	26	75	12	4	●	2
MS4MRBD1200R250	12	2.5	26	75	12	4	●	2
MS4MRBD1200R300	12	3	26	75	12	4	●	2
MS4MRBD1600R050	16	0.5	32	90	16	4	●	2
MS4MRBD1600R100	16	1	32	90	16	4	●	2
MS4MRBD1600R150	16	1.5	32	90	16	4	●	2
MS4MRBD1600R200	16	2	32	90	16	4	●	2
MS4MRBD1600R250	16	2.5	32	90	16	4	●	2
MS4MRBD1600R300	16	3	32	90	16	4	●	2
MS4MRBD2000R050	20	0.5	38	100	20	4	●	2
MS4MRBD2000R100	20	1	38	100	20	4	●	2
MS4MRBD2000R150	20	1.5	38	100	20	4	●	2
MS4MRBD2000R200	20	2	38	100	20	4	●	2
MS4MRBD2000R250	20	2.5	38	100	20	4	●	2
MS4MRBD2000R300	20	3	38	100	20	4	●	2

SOLID END MILLS

SQUARE

BALL

RADIUS

TAPER

BARREL

ROUGHING

MSTAR END MILLS

MS4MRB

Corner radius end mill, Medium cut length, 4 flute

CARBIDE

SOLID END MILLS

SQUARE

BALL

RADIUS

TAPER

BARREL

ROUGHING

RECOMMENDED CUTTING CONDITIONS

Work material	P				M	S	H	
	Revolution (min ⁻¹)	Feed rate (mm/min)	Revolution (min ⁻¹)	Feed rate (mm/min)	Revolution (min ⁻¹)	Feed rate (mm/min)	Revolution (min ⁻¹)	Feed rate (mm/min)
Carbon steel, Cast iron, Alloy steel (—30HRC) Cf53, GG25			Alloy steel, Tool steel, Pre-hardened steel X40CrMoV51		Austenitic stainless steel, Titanium alloy X5CrNi1810, X5CrNiMo17122, Ti6Al4V		Hardened steel (45—55HRC) X40CrMoV51	
3	16000	1500	10000	800	7400	480	8000	240
4	12000	1800	8000	1000	5600	600	6000	240
5	9600	1800	6400	1000	4400	600	4800	240
6	8000	1800	5300	1000	3700	600	4000	240
8	6000	1600	4000	900	2800	560	3000	240
10	4800	1400	3200	800	2200	500	2400	240
12	4000	1200	2700	700	1800	430	2000	230
16	3000	960	2000	560	1400	360	1500	190
20	2400	800	1600	480	1100	300	1200	170

Depth of cut	Diagram 1	Diagram 2	Diagram 3

DC: Dia.

Note 1) When cutting austenitic stainless steels, the use of water-soluble cutting fluid is effective.

Note 2) If the depth of cut is shallow, the revolution and feed rate can be increased.

Note 3) When drilling, please set the feed rate at 1/3 or below the values above.

Note 4) If the rigidity of the machine or the work materials installation is very low, or chattering and noise are generated, reduce the revolution and feed rate proportionately.

MS6MH...E/MS8MH...E

End mill, Medium cut length, 6/8 flutes



CARBIDE

Carbon Steel, Alloy Steel, Cast Iron (<30HRC)	Tool Steel, Pre-Hardened Steel, Hardened Steel (≤45HRC)	Hardened Steel (≤55HRC)	Hardened Steel (>55HRC)	Austenitic Stainless Steel	Titanium Alloy, Heat Resistant Alloy	Copper Alloy	Aluminium Alloy
○	○	○		○	○	○	

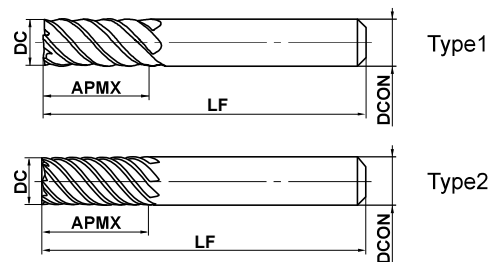

DC=6	6<DC≤16	DC=20		
- 0.015 - 0.038	- 0.020 - 0.047	- 0.020 - 0.053		
DCON=6	8≤DCON≤10	12≤DCON≤16	DCON=20	
0 - 0.008	0 - 0.009	0 - 0.011	0 - 0.013	



- Multi flute end mill for general use and difficult to cut materials.
- Centre cutting.

(mm)

Order Number	DC	APMX	LF	DCON	Flutes	Stock	Type
MS6MHD0600E	6	13	60	6	6	●	1
MS6MHD0800E	8	19	60	8	6	●	1
MS6MHD1000E	10	22	75	10	6	●	1
MS6MHD1200E	12	26	75	12	6	●	1
MS6MHD1600E	16	32	90	16	6	●	1
MS8MHD2000E	20	36	100	20	8	●	2

SOLID END MILLS

SQUARE

BALL

RADIUS

TAPER

BARREL

ROUGHING

● : Inventory maintained.

MSTAR END MILLS

MS6MH...E/MS8MH...E

End mill, Medium cut length, 6/8 flutes

CARBIDE

RECOMMENDED CUTTING CONDITIONS

Work material	P				H	M	S
	Carbon steel, Alloy steel (-30HRC) Cast iron		Alloy steel, Tool steel, Pre-hardened steel (30-45HRC)		Stainless steel, Hardened steel (45-55HRC) Heat resistant steel		
Dia. DC (mm)	Revolution (min ⁻¹)	Feed rate (mm/min)	Revolution (min ⁻¹)	Feed rate (mm/min)	Revolution (min ⁻¹)	Feed rate (mm/min)	
6	20000	8100	14000	5400	12000	4080	
8	16000	7200	11200	4680	9600	3540	
10	12800	6000	8800	4080	7600	3060	
12	10800	5580	7600	3720	6400	2820	
16	8000	3600	5600	2520	4800	2160	
20	6400	2880	4400	1980	3800	1800	

Depth of cut

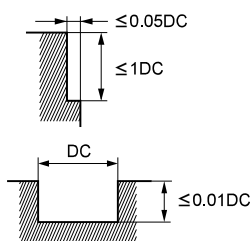

DC: Dia.

SOLID END MILLS

SQUARE

BALL

RADIUS

TAPER

BARREL

ROUGHING

Work material	S			
	Titanium TiAl6V4		Nickel (Heat resistant alloys) Inconel 718	
Dia. DC (mm)	Revolution (min ⁻¹)	Feed rate (mm/min)	Revolution (min ⁻¹)	Feed rate (mm/min)
6	8000	2700	2100	710
8	6000	2200	1600	590
10	5000	2000	1200	480
12	4000	1760	1000	440
16	3000	1350	800	360
20	2400	1150	640	300

Depth of cut

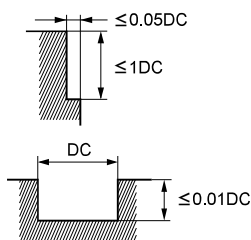

DC: Dia.

MS PLUS END MILLS

MP2SSB

Ball nose, Short cut length, Short shank, 2 flute



CARBIDE

Carbon Steel, Alloy Steel, Cast Iron (<30HRC)	Tool Steel, Pre-Hardened Steel, Hardened Steel (≤45HRC)	Hardened Steel (≤55HRC)	Hardened Steel (>55HRC)	Austenitic Stainless Steel	Titanium Alloy, Heat Resistant Alloy	Copper Alloy	Aluminium Alloy
○	○	○		○	○	○	

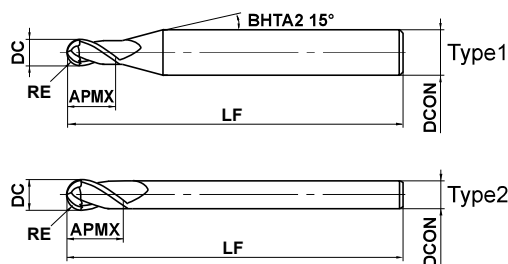

$0.1 \leq RE \leq 6$				
± 0.005				



$4 \leq DCON \leq 6$	$8 \leq DCON \leq 10$	$DCON = 12$		
$\begin{matrix} 0 \\ -0.005 \end{matrix}$	$\begin{matrix} 0 \\ -0.006 \end{matrix}$	$\begin{matrix} 0 \\ -0.008 \end{matrix}$		

● 2-flute ball nose end mills with short cutting edge length for general purpose. Excellent performance over a wide range of workpiece materials such as carbon, alloy and hardened steels.

(mm)

Order Number	RE	DC	APMX	LF	DCON	Flutes	Stock	Type
MP2SSBR0010	0.1	0.2	0.2	40	4	2	●	1
MP2SSBR0020	0.2	0.4	0.4	40	4	2	●	1
MP2SSBR0030	0.3	0.6	0.6	40	4	2	●	1
MP2SSBR0040	0.4	0.8	0.8	40	4	2	●	1
MP2SSBR0050	0.5	1	1	40	4	2	●	1
MP2SSBR0050S06	0.5	1	1	40	6	2	●	1
MP2SSBR0075	0.75	1.5	1.5	40	4	2	●	1
MP2SSBR0075S06	0.75	1.5	1.5	40	6	2	●	1
MP2SSBR0100	1	2	2	45	6	2	●	1
MP2SSBR0150	1.5	3	3	45	6	2	●	1
MP2SSBR0200	2	4	4	45	6	2	●	1
MP2SSBR0250	2.5	5	5	50	6	2	●	1
MP2SSBR0300	3	6	6	50	6	2	●	2
MP2SSBR0400	4	8	8	60	8	2	●	2
MP2SSBR0500	5	10	10	70	10	2	●	2
MP2SSBR0600	6	12	12	75	12	2	●	2

SOLID END MILLS

SQUARE

BALL

RADIUS

TAPER

BARREL

ROUGHING

● : Inventory maintained.

MS PLUS END MILLS

MP2SB

Ball nose, Short cut length, 2 flute



Carbon Steel, Alloy Steel, Cast Iron (<30HRC)	Tool Steel, Pre-Hardened Steel, Hardened Steel (≤45HRC)	Hardened Steel (≤55HRC)	Hardened Steel (>55HRC)	Austenitic Stainless Steel	Titanium Alloy, Heat Resistant Alloy	Copper Alloy	Aluminium Alloy
○	○	○		○	○	○	

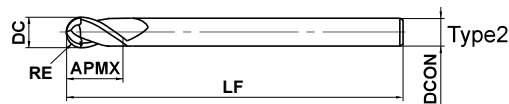
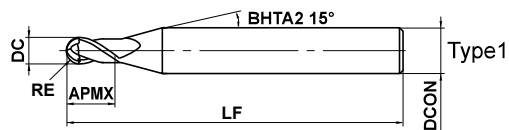

SOLID END MILLS



0.1 ≤ RE ≤ 6				
±0.005				
4 ≤ DCON ≤ 6	8 ≤ DCON ≤ 10	DCON = 12		
0 - 0.005	0 - 0.006	0 - 0.008		

● 2-flute ball nose end mills with short cutting edge length for general purpose. Excellent performance over a wide range of workpiece materials such as carbon, alloy and hardened steels.

(mm)

Order Number	RE	DC	APMX	LF	DCON	Flutes	Stock	Type
MP2SBR0010	0.1	0.2	0.3	45	4	2	●	1
MP2SBR0015	0.15	0.3	0.5	45	4	2	●	1
MP2SBR0020	0.2	0.4	0.6	45	4	2	●	1
MP2SBR0020S06	0.2	0.4	0.6	50	6	2	●	1
MP2SBR0025	0.25	0.5	0.8	45	4	2	●	1
MP2SBR0030	0.3	0.6	0.9	45	4	2	●	1
MP2SBR0030S06	0.3	0.6	0.9	50	6	2	●	1
MP2SBR0035	0.35	0.7	1.1	45	4	2	●	1
MP2SBR0040	0.4	0.8	1.2	45	4	2	●	1
MP2SBR0040S06	0.4	0.8	1.2	50	6	2	●	1
MP2SBR0045	0.45	0.9	1.4	45	4	2	●	1
MP2SBR0050	0.5	1	1.5	45	4	2	●	1
MP2SBR0050S06	0.5	1	1.5	50	6	2	●	1
MP2SBR0060	0.6	1.2	1.8	45	4	2	●	1
MP2SBR0070	0.7	1.4	2.1	45	4	2	●	1
MP2SBR0075	0.75	1.5	2.3	45	4	2	●	1
MP2SBR0075S06	0.75	1.5	2.3	50	6	2	●	1
MP2SBR0080	0.8	1.6	2.4	45	4	2	●	1
MP2SBR0090	0.9	1.8	2.7	45	4	2	●	1
MP2SBR0100	1	2	3	50	4	2	●	1
MP2SBR0100S06	1	2	3	50	6	2	●	1
MP2SBR0125	1.25	2.5	3.8	50	4	2	●	1
MP2SBR0150	1.5	3	4.5	70	6	2	●	1
MP2SBR0200	2	4	6	70	6	2	●	1
MP2SBR0250	2.5	5	7.5	80	6	2	●	1
MP2SBR0300	3	6	9	80	6	2	●	2
MP2SBR0400	4	8	12	90	8	2	●	2
MP2SBR0500	5	10	15	100	10	2	●	2
MP2SBR0600	6	12	18	110	12	2	●	2

SQUARE

BALL

RADIUS

TAPER

BARREL

ROUGHING

● : Inventory maintained.

MP2MB

Ball nose, Medium cut length, 2 flute



CARBIDE

Carbon Steel, Alloy Steel, Cast Iron (<30HRC)	Tool Steel, Pre-Hardened Steel, Hardened Steel (<=45HRC)	Hardened Steel (<=55HRC)	Hardened Steel (>55HRC)	Austenitic Stainless Steel	Titanium Alloy, Heat Resistant Alloy	Copper Alloy	Aluminium Alloy
○	○	○		○	○	○	

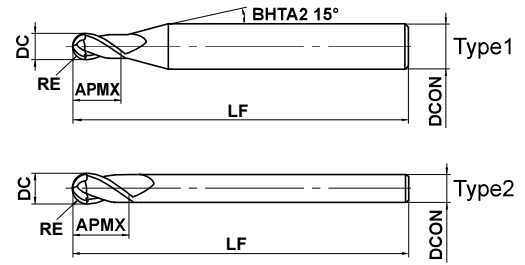

	0.25 ≤ RE ≤ 6				
	±0.005				
	4 ≤ DCON ≤ 6	8 ≤ DCON ≤ 10	DCON = 12		
	⁰ / _{-0.005}	⁰ / _{-0.006}	⁰ / _{-0.008}		

● 2-flute ball nose end mills with medium cutting edge length for general purpose. Excellent performance over a wide range of workpiece materials such as carbon, alloy and hardened steels.

(mm)

Order Number	RE	DC	APMX	LF	DCON	Flutes	Stock	Type
MP2MBR0025	0.25	0.5	1	45	4	2	●	1
MP2MBR0030	0.3	0.6	1.2	45	4	2	●	1
MP2MBR0040	0.4	0.8	1.6	45	4	2	●	1
MP2MBR0050	0.5	1	2.5	45	4	2	●	1
MP2MBR0060	0.6	1.2	2.5	45	4	2	●	1
MP2MBR0070	0.7	1.4	3	45	4	2	●	1
MP2MBR0075	0.75	1.5	4	45	4	2	●	1
MP2MBR0080	0.8	1.6	4	45	4	2	●	1
MP2MBR0090	0.9	1.8	5	45	4	2	●	1
MP2MBR0100	1	2	6	50	4	2	●	1
MP2MBR0125	1.25	2.5	6	50	4	2	●	1
MP2MBR0150S03	1.5	3	8	70	3	2	●	2
MP2MBR0150	1.5	3	8	70	6	2	●	1
MP2MBR0175	1.75	3.5	8	70	6	2	●	1
MP2MBR0200S04	2	4	8	70	4	2	●	2
MP2MBR0200	2	4	8	70	6	2	●	1
MP2MBR0250	2.5	5	12	80	6	2	●	1
MP2MBR0300	3	6	12	80	6	2	●	2
MP2MBR0400	4	8	14	90	8	2	●	2
MP2MBR0500	5	10	18	100	10	2	●	2
MP2MBR0600	6	12	22	110	12	2	●	2

SOLID END MILLS

SQUARE

BALL

RADIUS

TAPER

BARREL

ROUGHING

MS PLUS END MILLS

MP2SSB Ball nose, Short cut length, Short shank, 2 flute

MP2SB Ball nose, Short cut length, 2 flute **MP2MB** Ball nose, Medium cut length, 2 flute

RECOMMENDED CUTTING CONDITIONS

Work material	P						M					
	$\alpha \leq 15^\circ$		$\alpha > 15^\circ$		Depth of cut a_p (mm)	Depth of cut a_e (mm)	$\alpha \leq 15^\circ$		$\alpha > 15^\circ$		Depth of cut a_p (mm)	Depth of cut a_e (mm)
	Revolution (min ⁻¹)	Feed rate (mm/min)	Revolution (min ⁻¹)	Feed rate (mm/min)			Revolution (min ⁻¹)	Feed rate (mm/min)	Revolution (min ⁻¹)	Feed rate (mm/min)		
R0.1	40000	300	40000	250	0.003	0.02	40000	300	40000	250	0.003	0.02
R0.15	40000	500	40000	350	0.007	0.03	40000	500	40000	350	0.007	0.03
R0.2	40000	1600	40000	1200	0.02	0.04	40000	1300	40000	1000	0.015	0.04
R0.25	40000	2400	40000	1400	0.025	0.05	40000	1900	40000	1200	0.02	0.05
R0.3	40000	3200	40000	1600	0.03	0.06	40000	2400	40000	1400	0.025	0.06
R0.4	40000	4800	40000	2400	0.05	0.08	40000	2400	40000	1900	0.04	0.08
R0.5	40000	5600	40000	3200	0.06	0.1	40000	3200	38000	2400	0.05	0.1
R0.75	40000	6500	40000	4000	0.09	0.15	40000	3200	25000	1600	0.08	0.15
R1	40000	6500	39000	4700	0.11	0.2	32000	3200	19000	1500	0.11	0.2
R1.25	40000	7000	33000	4500	0.12	0.25	25000	2500	15000	1200	0.12	0.25
R1.5	40000	7500	27000	4300	0.13	0.3	21000	2100	13000	1100	0.13	0.3
R2	32000	7500	20000	3600	0.15	0.4	16000	1900	9500	900	0.15	0.4
R2.5	25000	6000	16000	2900	0.2	0.5	13000	1600	7600	750	0.2	0.5
R3	21000	5800	13000	2600	0.25	0.6	11000	1500	6400	700	0.25	0.6
R4	16000	4500	10000	2000	0.3	0.8	8000	1400	4800	670	0.3	0.8
R5	13000	3600	8000	1700	0.5	1.0	6400	1300	3800	620	0.5	1.0
R6	9000	2500	6000	1300	0.5	1.2	5300	1300	3200	620	0.5	1.2

Work material	H						N					
	$\alpha \leq 15^\circ$		$\alpha > 15^\circ$		Depth of cut a_p (mm)	Depth of cut a_e (mm)	$\alpha \leq 15^\circ$		$\alpha > 15^\circ$		Depth of cut a_p (mm)	Depth of cut a_e (mm)
	Revolution (min ⁻¹)	Feed rate (mm/min)	Revolution (min ⁻¹)	Feed rate (mm/min)			Revolution (min ⁻¹)	Feed rate (mm/min)	Revolution (min ⁻¹)	Feed rate (mm/min)		
R0.1	40000	300	40000	250	0.003	0.02	40000	300	40000	250	0.003	0.02
R0.15	40000	500	40000	350	0.007	0.03	40000	500	40000	350	0.007	0.03
R0.2	40000	1300	40000	950	0.015	0.04	40000	1300	40000	950	0.015	0.04
R0.25	40000	1900	40000	1100	0.02	0.05	40000	1900	40000	1100	0.02	0.05
R0.3	40000	2500	40000	1300	0.025	0.06	40000	2500	40000	1300	0.025	0.06
R0.4	40000	4000	40000	1900	0.04	0.08	40000	4000	40000	1900	0.04	0.08
R0.5	40000	5600	40000	3000	0.05	0.1	40000	5600	40000	3000	0.05	0.1
R0.75	40000	6500	32000	3200	0.08	0.15	40000	6500	32000	3200	0.08	0.15
R1	40000	6500	31000	3500	0.11	0.2	40000	6500	31000	3500	0.11	0.2
R1.25	36000	6500	26000	3500	0.12	0.25	36000	6500	26000	3500	0.12	0.25
R1.5	32000	6000	22000	3400	0.13	0.3	32000	6000	22000	3400	0.13	0.3
R2	25000	6000	16000	2700	0.15	0.4	25000	6000	16000	2700	0.15	0.6
R2.5	20000	5400	13000	2300	0.2	0.5	20000	5400	13000	2300	0.2	0.75
R3	17000	4700	10000	2000	0.25	0.6	17000	4700	10000	2000	0.25	0.9
R4	13000	3600	8000	1500	0.3	0.8	13000	3600	8000	1500	0.3	1.6
R5	10000	2900	6400	1200	0.5	1.0	10000	2900	6400	1200	0.5	2.0
R6	7200	2000	4800	1000	0.5	1.2	8500	2300	5300	1100	0.5	2.4



- Note 1) α is the inclination angle of the machined surface.
- Note 2) If the depth of cut is shallow, the revolution and feed rate can be increased.
- Note 3) If the rigidity of the machine or the work materials installation is very low, or chattering and noise are generated, reduce the revolution and feed rate proportionately.
- Note 4) Standard cutting conditions of austenitic stainless steel and titanium alloy, please reduce the revolution by 40% and the feedrate by 55%.
(Hardened steel (45—55HRC) table above)

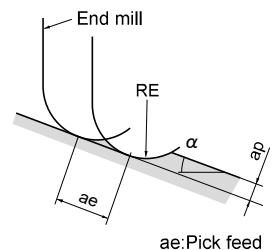

MP2SDB

Ball nose, Short cut length, High strength, 2 flute



CARBIDE

Carbon Steel, Alloy Steel, Cast Iron (<30HRC)	Tool Steel, Pre-Hardened Steel, Hardened Steel (≤45HRC)	Hardened Steel (≤55HRC)	Hardened Steel (>55HRC)	Austenitic Stainless Steel	Titanium Alloy, Heat Resistant Alloy	Copper Alloy	Aluminium Alloy
---	---	-------------------------	-------------------------	----------------------------	--------------------------------------	--------------	-----------------

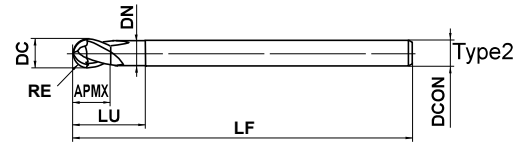
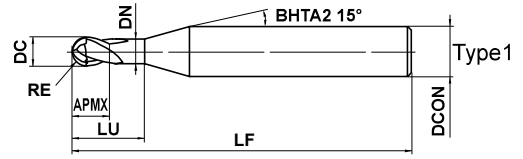

	0.5 ≤ RE ≤ 6				
	±0.01				
	4 ≤ DCON ≤ 6	DCON=8			
	⁰ / _{-0.005}	⁰ / _{-0.006}			
	DCON=10	DCON=12			
	⁰ / _{-0.009}	⁰ / _{-0.011}			

- Excellent chipping resistance with a strong S curve cutting edge. Ideal for semi finish machining of forging dies.

(mm)

Order Number	RE	DC	APMX	LU	DN	LF	DCON	Flutes	Stock	Type
MP2SDBR0050	0.5	1	1	2	0.96	45	4	2	●	1
MP2SDBR0075S06	0.75	1.5	1.5	3	1.44	50	6	2	●	1
MP2SDBR0100	1	2	2	4	1.90	50	4	2	●	1
MP2SDBR0100S06	1	2	2	4	1.90	60	6	2	●	1
MP2SDBR0150	1.5	3	3	6	2.90	70	6	2	●	1
MP2SDBR0200	2	4	4	8	3.90	60	4	2	●	2
MP2SDBR0200S06	2	4	4	8	3.90	70	6	2	●	1
MP2SDBR0250	2.5	5	5	10	4.90	80	6	2	●	1
MP2SDBR0300	3	6	12	18	5.85	80	6	2	●	2
MP2SDBR0300A120	3	6	12	18	5.85	120	6	2	●	2
MP2SDBR0400	4	8	14	24	7.85	90	8	2	●	2
MP2SDBR0400A130	4	8	14	24	7.85	130	8	2	●	2
MP2SDBR0500	5	10	18	30	9.70	100	10	2	●	2
MP2SDBR0500A140	5	10	18	30	9.70	140	10	2	●	2
MP2SDBR0600	6	12	22	36	11.70	110	12	2	●	2
MP2SDBR0600A140	6	12	22	36	11.70	140	12	2	●	2

SOLID END MILLS

SQUARE

BALL

RADIUS

TAPER

BARREL

ROUGHING

● : Inventory maintained.

MS PLUS END MILLS

MP2SDB

Ball nose, Short cut length, High strength, 2 flute

CARBIDE

SOLID END MILLS

SQUARE

BALL

RADIUS

TAPER

BARREL

ROUGHING

RECOMMENDED CUTTING CONDITIONS

Overhang below 5D (D:Dia.)

Work material	P						H						
	$\alpha \leq 15^\circ$		$\alpha > 15^\circ$		Depth of cut ae (mm)	Depth of cut ae (mm)	$\alpha \leq 15^\circ$		$\alpha > 15^\circ$		Depth of cut ae (mm)	Depth of cut ae (mm)	
	Revolution (min ⁻¹)	Feed rate (mm/min)	Revolution (min ⁻¹)	Feed rate (mm/min)			Revolution (min ⁻¹)	Feed rate (mm/min)	Revolution (min ⁻¹)	Feed rate (mm/min)			
Carbon steel, Alloy steel, Alloy tool steel, Tool steel, Pre-hardened steel							Hardened steel (45–55HRC)						
R 0.5	40000	3900	36000	2100	0.1	0.25	40000	4300	36000	2200	0.1	0.25	
R 0.75	40000	4200	36000	2600	0.15	0.35	40000	4700	36000	2700	0.15	0.35	
R 1	40000	4500	36000	3100	0.2	0.5	40000	5000	36000	3300	0.2	0.5	
R 1.5	37000	5300	24000	2700	0.3	0.75	37000	5800	24000	2800	0.3	0.75	
R 2X4	24000	3200	15000	2000	0.25	0.7	19000	2800	13000	1600	0.25	0.7	
R 2	30000	4900	19000	2500	0.4	1	28000	5000	19000	2400	0.4	1	
R 2.5	25000	4500	16000	2300	0.5	1.3	22000	4200	16000	2200	0.5	1.25	
R 3	22000	4300	14000	2200	0.6	1.8	18000	3800	12000	1800	0.6	1.5	
R 4	19000	3900	12000	2000	0.8	2.4	15000	3200	9500	1600	0.8	2	
R 5	15000	3300	9500	1800	1	3	11000	2500	7000	1400	1	2.5	
R 6	12000	2550	8000	1600	1.2	3.6	9000	2000	6000	1300	1.2	3	

Overhang below 7D (D:Dia.)

Work material	P						H						
	$\alpha \leq 15^\circ$		$\alpha > 15^\circ$		Depth of cut ae (mm)	Depth of cut ae (mm)	$\alpha \leq 15^\circ$		$\alpha > 15^\circ$		Depth of cut ae (mm)	Depth of cut ae (mm)	
	Revolution (min ⁻¹)	Feed rate (mm/min)	Revolution (min ⁻¹)	Feed rate (mm/min)			Revolution (min ⁻¹)	Feed rate (mm/min)	Revolution (min ⁻¹)	Feed rate (mm/min)			
Carbon steel, Alloy steel, Alloy tool steel, Tool steel, Pre-hardened steel							Hardened steel (45–55HRC)						
R 3	10000	1500	6900	1000	0.2	1	8000	1400	5300	770	0.2	0.8	
R 4	8000	1400	5600	900	0.3	1.5	6400	1300	4000	650	0.3	1.2	
R 5	6000	1200	4100	740	0.4	2	4800	1100	3200	580	0.4	1.6	
R 6	5000	1000	3400	600	0.45	2.4	4000	900	2700	490	0.45	2	

Note 1) α is the inclination of the machined surface.

Note 2) If the depth of cut is smaller than this table, feed rate can be increased.

Note 3) If the rigidity of the machine or the workpiece installation is very low, or chattering is generated, please reduce the revolution and the feed rate proportionately.

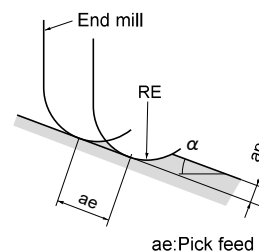

MP2XLB

Ball nose, Short cut length, Long neck, 2 flute



CARBIDE

Carbon Steel, Alloy Steel, Cast Iron (<30HRC)	Tool Steel, Pre-Hardened Steel, Hardened Steel (≤45HRC)	Hardened Steel (≤55HRC)	Hardened Steel (>55HRC)	Austenitic Stainless Steel	Titanium Alloy, Heat Resistant Alloy	Copper Alloy	Aluminium Alloy
○	○	○		○	○	○	



Effective length for inclined angle

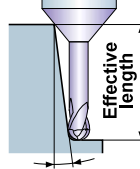

Inclined angle

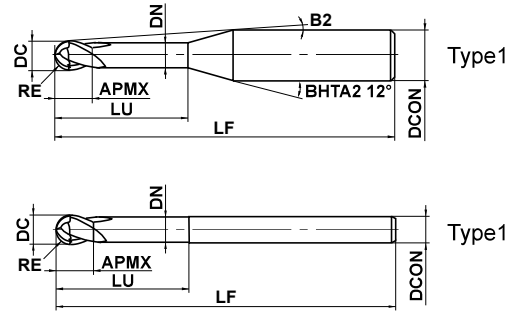

0.05 ≤ RE ≤ 3

±0.005



4 ≤ DCON ≤ 6

0
- 0.005

● 2-flute long neck ball nose end mills. Excellent performance over a wide range of workpiece materials such as carbon, alloy and hardened steels.

(mm)

Order Number	RE	DC	APMX	LU	DN	B2	LF	DCON	Flutes	Stock	Type	Effective length for inclined angle			
												0.5°	1°	2°	3°
MP2XLB0005N003	0.05	0.1	0.08	0.3	0.085	11.6°	50	4	2	●	1	0.3	0.3	0.4	0.4
MP2XLB0005N005	0.05	0.1	0.08	0.5	0.085	11.4°	50	4	2	●	1	0.5	0.5	0.6	0.7
MP2XLB0010N005	0.1	0.2	0.15	0.5	0.18	11.5°	50	4	2	●	1	0.5	0.5	0.6	0.7
MP2XLB0010N008	0.1	0.2	0.15	0.75	0.18	11.2°	50	4	2	●	1	0.8	0.8	0.9	1.0
MP2XLB0010N010	0.1	0.2	0.15	1	0.18	10.9°	50	4	2	●	1	1.0	1.1	1.2	1.3
MP2XLB0010N013	0.1	0.2	0.15	1.25	0.18	10.6°	50	4	2	●	1	1.3	1.4	1.5	1.7
MP2XLB0010N015	0.1	0.2	0.15	1.5	0.18	10.4°	50	4	2	●	1	1.6	1.6	1.8	2.0
MP2XLB0010N018	0.1	0.2	0.15	1.75	0.18	10.2°	50	4	2	●	1	1.8	1.9	2.1	2.3
MP2XLB0010N020	0.1	0.2	0.15	2	0.18	9.9°	50	4	2	●	1	2.1	2.2	2.4	2.6
MP2XLB0010N025	0.1	0.2	0.15	2.5	0.18	9.5°	50	4	2	●	1	2.6	2.7	3.0	3.3
MP2XLB0015N005	0.15	0.3	0.24	0.5	0.28	11.5°	50	4	2	●	1	0.5	0.5	0.6	0.6
MP2XLB0015N008	0.15	0.3	0.24	0.75	0.28	11.2°	50	4	2	●	1	0.8	0.8	0.9	1.0
MP2XLB0015N010	0.15	0.3	0.24	1	0.28	10.9°	50	4	2	●	1	1.0	1.1	1.2	1.3
MP2XLB0015N010S06	0.15	0.3	0.24	1	0.28	11.3°	50	6	2	●	1	1.0	1.1	1.2	1.3
MP2XLB0015N013	0.15	0.3	0.24	1.25	0.28	10.7°	50	4	2	●	1	1.3	1.4	1.5	1.6
MP2XLB0015N013S06	0.15	0.3	0.24	1.25	0.28	11.1°	50	6	2	●	1	1.3	1.4	1.5	1.6
MP2XLB0015N015	0.15	0.3	0.24	1.5	0.28	10.4°	50	4	2	●	1	1.6	1.6	1.8	2.0
MP2XLB0015N015S06	0.15	0.3	0.24	1.5	0.28	10.9°	50	6	2	●	1	1.6	1.6	1.8	2.0
MP2XLB0015N018	0.15	0.3	0.24	1.75	0.28	10.2°	50	4	2	●	1	1.8	1.9	2.1	2.3
MP2XLB0015N020	0.15	0.3	0.24	2	0.28	9.9°	50	4	2	●	1	2.1	2.2	2.4	2.6
MP2XLB0015N025	0.15	0.3	0.24	2.5	0.28	9.5°	50	4	2	●	1	2.6	2.7	3.0	3.3
MP2XLB0015N030	0.15	0.3	0.24	3	0.28	9.1°	50	4	2	●	1	3.1	3.3	3.6	4.0
MP2XLB0015N035	0.15	0.3	0.24	3.5	0.28	8.7°	50	4	2	●	1	3.7	3.8	4.2	4.6
MP2XLB0015N040	0.15	0.3	0.24	4	0.28	8.4°	50	4	2	●	1	4.2	4.4	4.8	5.3
MP2XLB0020N005	0.2	0.4	0.3	0.5	0.37	11.6°	50	4	2	●	1	0.5	0.5	0.5	0.6
MP2XLB0020N008	0.2	0.4	0.3	0.75	0.37	11.3°	50	4	2	●	1	0.7	0.8	0.9	0.9
MP2XLB0020N010	0.2	0.4	0.3	1	0.37	11°	50	4	2	●	1	1.0	1.1	1.2	1.3
MP2XLB0020N010S06	0.2	0.4	0.3	1	0.37	11.3°	50	6	2	●	1	1.0	1.1	1.2	1.3
MP2XLB0020N015	0.2	0.4	0.3	1.5	0.37	10.4°	50	4	2	●	1	1.5	1.6	1.7	1.9
MP2XLB0020N020	0.2	0.4	0.3	2	0.37	9.9°	50	4	2	●	1	2.1	2.2	2.3	2.6
MP2XLB0020N020S06	0.2	0.4	0.3	2	0.37	10.6°	50	6	2	●	1	2.1	2.2	2.3	2.6
MP2XLB0020N025	0.2	0.4	0.3	2.5	0.37	9.5°	50	4	2	●	1	2.6	2.7	2.9	3.3
MP2XLB0020N030	0.2	0.4	0.3	3	0.37	9.1°	50	4	2	●	1	3.1	3.2	3.5	3.9
MP2XLB0020N035	0.2	0.4	0.3	3.5	0.37	8.7°	50	4	2	●	1	3.6	3.8	4.1	4.6

● : Inventory maintained.

SOLID END MILLS

SQUARE

BALL

RADIUS

TAPER

BARREL

ROUGHING

MS PLUS END MILLS

MP2XLB

Ball nose, Short cut length, Long neck, 2 flute

(mm)

Order Number	RE	DC	APMX	LU	DN	B2	LF	DCON	Flutes	Stock	Type	Effective length for inclined angle			
												0.5°	1°	2°	3°
MP2XLBR0020N040	0.2	0.4	0.3	4	0.37	8.4°	50	4	2	●	1	4.2	4.3	4.7	5.2
MP2XLBR0020N045	0.2	0.4	0.3	4.5	0.37	8°	50	4	2	●	1	4.7	4.9	5.3	5.9
MP2XLBR0020N050	0.2	0.4	0.3	5	0.37	7.7°	50	4	2	●	1	5.2	5.4	5.9	6.6
MP2XLBR0020N055	0.2	0.4	0.3	5.5	0.37	7.5°	50	4	2	●	1	5.7	6.0	6.5	7.2
MP2XLBR0020N060	0.2	0.4	0.3	6	0.37	7.2°	50	4	2	●	1	6.2	6.5	7.1	7.9
MP2XLBR0025N010	0.25	0.5	0.37	1	0.47	11°	50	4	2	●	1	1.0	1.0	1.1	1.2
MP2XLBR0025N015	0.25	0.5	0.37	1.5	0.47	10.4°	50	4	2	●	1	1.5	1.6	1.7	1.9
MP2XLBR0025N015S06	0.25	0.5	0.37	1.5	0.47	11°	50	6	2	●	1	1.5	1.6	1.7	1.9
MP2XLBR0025N020	0.25	0.5	0.37	2	0.47	9.9°	50	4	2	●	1	2.1	2.1	2.3	2.6
MP2XLBR0025N020S06	0.25	0.5	0.37	2	0.47	10.6°	50	6	2	●	1	2.1	2.1	2.3	2.6
MP2XLBR0025N025	0.25	0.5	0.37	2.5	0.47	9.5°	50	4	2	●	1	2.6	2.7	2.9	3.2
MP2XLBR0025N025S06	0.25	0.5	0.37	2.5	0.47	10.3°	50	6	2	●	1	2.6	2.7	2.9	3.2
MP2XLBR0025N030	0.25	0.5	0.37	3	0.47	9.1°	50	4	2	●	1	3.1	3.2	3.5	3.9
MP2XLBR0025N030S06	0.25	0.5	0.37	3	0.47	10°	50	6	2	●	1	3.1	3.2	3.5	3.9
MP2XLBR0025N035	0.25	0.5	0.37	3.5	0.47	8.7°	50	4	2	●	1	3.6	3.8	4.1	4.6
MP2XLBR0025N040	0.25	0.5	0.37	4	0.47	8.3°	50	4	2	●	1	4.1	4.3	4.7	5.2
MP2XLBR0025N045	0.25	0.5	0.37	4.5	0.47	8°	50	4	2	●	1	4.7	4.9	5.3	5.9
MP2XLBR0025N050	0.25	0.5	0.37	5	0.47	7.7°	50	4	2	●	1	5.2	5.4	5.9	6.6
MP2XLBR0025N055	0.25	0.5	0.37	5.5	0.47	7.4°	50	4	2	●	1	5.7	6.0	6.5	7.2
MP2XLBR0025N060	0.25	0.5	0.37	6	0.47	7.2°	50	4	2	●	1	6.2	6.5	7.1	7.9
MP2XLBR0025N070	0.25	0.5	0.37	7	0.47	6.7°	50	4	2	●	1	7.3	7.6	8.3	9.2
MP2XLBR0025N080	0.25	0.5	0.37	8	0.47	6.3°	50	4	2	●	1	8.3	8.7	9.5	10.5
MP2XLBR0025N090	0.25	0.5	0.37	9	0.47	5.9°	50	4	2	●	1	9.4	9.8	10.7	11.9
MP2XLBR0025N100	0.25	0.5	0.37	10	0.47	5.6°	50	4	2	●	1	10.4	10.9	11.9	13.2
MP2XLBR0030N015	0.3	0.6	0.45	1.5	0.57	10.4°	50	4	2	●	1	1.5	1.6	1.8	2.0
MP2XLBR0030N015S06	0.3	0.6	0.45	1.5	0.57	11°	50	6	2	●	1	1.5	1.6	1.8	2.0
MP2XLBR0030N020	0.3	0.6	0.45	2	0.57	9.9°	50	4	2	●	1	2.1	2.2	2.4	2.6
MP2XLBR0030N020S06	0.3	0.6	0.45	2	0.57	10.6°	50	6	2	●	1	2.1	2.2	2.4	2.6
MP2XLBR0030N025	0.3	0.6	0.45	2.5	0.57	9.4°	50	4	2	●	1	2.6	2.7	3.0	3.3
MP2XLBR0030N030	0.3	0.6	0.45	3	0.57	9°	50	4	2	●	1	3.1	3.3	3.6	4.0
MP2XLBR0030N030S06	0.3	0.6	0.45	3	0.57	9.9°	50	6	2	●	1	3.1	3.3	3.6	4.0
MP2XLBR0030N035	0.3	0.6	0.45	3.5	0.57	8.6°	50	4	2	●	1	3.7	3.8	4.2	4.6
MP2XLBR0030N040	0.3	0.6	0.45	4	0.57	8.2°	50	4	2	●	1	4.2	4.4	4.8	5.3
MP2XLBR0030N040S06	0.3	0.6	0.45	4	0.57	9.3°	50	6	2	●	1	4.2	4.4	4.8	5.3
MP2XLBR0030N045	0.3	0.6	0.45	4.5	0.57	7.9°	50	4	2	●	1	4.7	4.9	5.4	5.9
MP2XLBR0030N050	0.3	0.6	0.45	5	0.57	7.6°	50	4	2	●	1	5.2	5.5	6.0	6.6
MP2XLBR0030N050S06	0.3	0.6	0.45	5	0.57	8.8°	50	6	2	●	1	5.2	5.5	6.0	6.6
MP2XLBR0030N055	0.3	0.6	0.45	5.5	0.57	7.3°	50	4	2	●	1	5.8	6.0	6.6	7.3
MP2XLBR0030N060	0.3	0.6	0.45	6	0.57	7.1°	50	4	2	●	1	6.3	6.6	7.2	7.9
MP2XLBR0030N060S06	0.3	0.6	0.45	6	0.57	8.3°	50	6	2	●	1	6.3	6.6	7.2	7.9
MP2XLBR0030N065	0.3	0.6	0.45	6.5	0.57	6.8°	50	4	2	●	1	6.8	7.1	7.8	8.6
MP2XLBR0030N070	0.3	0.6	0.45	7	0.57	6.6°	50	4	2	●	1	7.3	7.6	8.4	9.3
MP2XLBR0030N080	0.3	0.6	0.45	8	0.57	6.2°	50	4	2	●	1	8.4	8.7	9.6	10.6
MP2XLBR0030N080S06	0.3	0.6	0.45	8	0.57	7.6°	50	6	2	●	1	8.4	8.7	9.6	10.6
MP2XLBR0030N085	0.3	0.6	0.45	8.5	0.57	6°	50	4	2	●	1	8.9	9.3	10.2	11.3
MP2XLBR0030N090	0.3	0.6	0.45	9	0.57	5.8°	50	4	2	●	1	9.4	9.8	10.8	11.9
MP2XLBR0030N095	0.3	0.6	0.45	9.5	0.57	5.7°	50	4	2	●	1	9.9	10.4	11.4	12.6
MP2XLBR0030N100	0.3	0.6	0.45	10	0.57	5.5°	50	4	2	●	1	10.5	10.9	12.0	13.2
MP2XLBR0030N110	0.3	0.6	0.45	11	0.57	5.2°	50	4	2	●	1	11.5	12.0	13.2	14.6
MP2XLBR0030N120	0.3	0.6	0.45	12	0.57	5°	50	4	2	●	1	12.5	13.1	14.4	15.9
MP2XLBR0040N020	0.4	0.8	0.6	2	0.77	9.9°	50	4	2	●	1	2.1	2.2	2.4	2.6
MP2XLBR0040N020S06	0.4	0.8	0.6	2	0.77	10.6°	50	6	2	●	1	2.1	2.2	2.4	2.6

● : Inventory maintained.

(mm)

Order Number	RE	DC	APMX	LU	DN	B2	LF	DCON	Flutes	Stock	Type	Effective length for inclined angle			
												0.5°	1°	2°	3°
MP2XLBR0040N024S06	0.4	0.8	0.6	2.4	0.77	10.3°	50	6	2	●	1	2.5	2.6	2.8	3.1
MP2XLBR0040N030	0.4	0.8	0.6	3	0.77	8.9°	50	4	2	●	1	3.1	3.3	3.6	3.9
MP2XLBR0040N030S06	0.4	0.8	0.6	3	0.77	9.9°	50	6	2	●	1	3.1	3.3	3.6	3.9
MP2XLBR0040N040	0.4	0.8	0.6	4	0.77	8.2°	50	4	2	●	1	4.2	4.4	4.8	5.2
MP2XLBR0040N040S06	0.4	0.8	0.6	4	0.77	9.3°	50	6	2	●	1	4.2	4.4	4.8	5.2
MP2XLBR0040N050	0.4	0.8	0.6	5	0.77	7.5°	50	4	2	●	1	5.2	5.5	6.0	6.6
MP2XLBR0040N060	0.4	0.8	0.6	6	0.77	6.9°	50	4	2	●	1	6.3	6.5	7.2	7.9
MP2XLBR0040N070	0.4	0.8	0.6	7	0.77	6.5°	50	4	2	●	1	7.3	7.6	8.4	9.2
MP2XLBR0040N080	0.4	0.8	0.6	8	0.77	6°	50	4	2	●	1	8.4	8.7	9.5	10.6
MP2XLBR0040N090	0.4	0.8	0.6	9	0.77	5.7°	50	4	2	●	1	9.4	9.8	10.7	11.9
MP2XLBR0040N100	0.4	0.8	0.6	10	0.77	5.4°	50	4	2	●	1	10.5	10.9	11.9	13.2
MP2XLBR0040N120	0.4	0.8	0.6	12	0.77	4.8°	50	4	2	●	1	12.5	13.1	14.3	15.9
MP2XLBR0050N030	0.5	1	0.75	3	0.96	8.7°	50	4	2	●	1	3.2	3.4	3.7	4.1
MP2XLBR0050N030S06	0.5	1	0.75	3	0.96	9.8°	50	6	2	●	1	3.2	3.4	3.7	4.1
MP2XLBR0050N040	0.5	1	0.75	4	0.96	7.9°	50	4	2	●	1	4.3	4.5	4.9	5.4
MP2XLBR0050N040S06	0.5	1	0.75	4	0.96	9.2°	50	6	2	●	1	4.3	4.5	4.9	5.4
MP2XLBR0050N050	0.5	1	0.75	5	0.96	7.3°	50	4	2	●	1	5.3	5.6	6.1	6.7
MP2XLBR0050N050S06	0.5	1	0.75	5	0.96	8.6°	50	6	2	●	1	5.3	5.6	6.1	6.7
MP2XLBR0050N060	0.5	1	0.75	6	0.96	6.7°	50	4	2	●	1	6.4	6.7	7.3	8.1
MP2XLBR0050N060S06	0.5	1	0.75	6	0.96	8.2°	50	6	2	●	1	6.4	6.7	7.3	8.1
MP2XLBR0050N070	0.5	1	0.75	7	0.96	6.2°	50	4	2	●	1	7.4	7.8	8.5	9.4
MP2XLBR0050N080	0.5	1	0.75	8	0.96	5.8°	50	4	2	●	1	8.5	8.9	9.7	10.7
MP2XLBR0050N080S06	0.5	1	0.75	8	0.96	7.3°	50	6	2	●	1	8.5	8.9	9.7	10.7
MP2XLBR0050N090	0.5	1	0.75	9	0.96	5.5°	50	4	2	●	1	9.5	10.0	10.9	12.0
MP2XLBR0050N100	0.5	1	0.75	10	0.96	5.1°	50	4	2	●	1	10.6	11.1	12.1	13.4
MP2XLBR0050N100S06	0.5	1	0.75	10	0.96	6.7°	60	6	2	●	1	10.6	11.1	12.1	13.4
MP2XLBR0050N120	0.5	1	0.75	12	0.96	4.6°	50	4	2	●	1	12.7	13.2	14.5	16.0
MP2XLBR0050N120S06	0.5	1	0.75	12	0.96	6.1°	60	6	2	●	1	12.7	13.2	14.5	16.0
MP2XLBR0050N140	0.5	1	0.75	14	0.96	4.2°	55	4	2	●	1	14.8	15.4	16.9	18.7
MP2XLBR0050N160	0.5	1	0.75	16	0.96	3.8°	55	4	2	●	1	16.9	17.6	19.3	21.3
MP2XLBR0050N160S06	0.5	1	0.75	16	0.96	5.2°	65	6	2	●	1	16.9	17.6	19.3	21.3
MP2XLBR0050N180	0.5	1	0.75	18	0.96	3.5°	55	4	2	●	1	18.9	19.8	21.7	24.0
MP2XLBR0050N200	0.5	1	0.75	20	0.96	3.3°	55	4	2	●	1	21.0	22.0	24.1	26.6
MP2XLBR0050N200S06	0.5	1	0.75	20	0.96	4.6°	65	6	2	●	1	21.0	22.0	24.1	26.6
MP2XLBR0060N060	0.6	1.2	0.9	6	1.16	6.6°	50	4	2	●	1	6.4	6.7	7.3	8.0
MP2XLBR0060N060S06	0.6	1.2	0.9	6	1.16	8.1°	55	6	2	●	1	6.4	6.7	7.3	8.0
MP2XLBR0060N080	0.6	1.2	0.9	8	1.16	5.7°	50	4	2	●	1	8.5	8.9	9.7	10.7
MP2XLBR0060N080S06	0.6	1.2	0.9	8	1.16	7.3°	55	6	2	●	1	8.5	8.9	9.7	10.7
MP2XLBR0060N100	0.6	1.2	0.9	10	1.16	5°	50	4	2	●	1	10.6	11.0	12.1	13.3
MP2XLBR0060N100S06	0.6	1.2	0.9	10	1.16	6.6°	55	6	2	●	1	10.6	11.0	12.1	13.3
MP2XLBR0060N120	0.6	1.2	0.9	12	1.16	4.4°	50	4	2	●	1	12.7	13.2	14.5	16.0
MP2XLBR0060N120S06	0.6	1.2	0.9	12	1.16	6°	65	6	2	●	1	12.7	13.2	14.5	16.0
MP2XLBR0060N140	0.6	1.2	0.9	14	1.16	4°	55	4	2	●	1	14.8	15.4	16.9	18.7
MP2XLBR0060N160	0.6	1.2	0.9	16	1.16	3.7°	55	4	2	●	1	16.9	17.6	19.3	21.3
MP2XLBR0060N160S06	0.6	1.2	0.9	16	1.16	5.1°	65	6	2	●	1	16.9	17.6	19.3	21.3
MP2XLBR0060N180	0.6	1.2	0.9	18	1.16	3.4°	60	4	2	●	1	18.9	19.8	21.7	24.0
MP2XLBR0060N200	0.6	1.2	0.9	20	1.16	3.1°	60	4	2	●	1	21.0	21.9	24.0	26.6
MP2XLBR0060N240	0.6	1.2	0.9	24	1.16	2.7°	60	4	2	●	1	25.2	26.3	28.8	*
MP2XLBR0070N080	0.7	1.4	1.05	8	1.34	5.5°	50	4	2	●	1	8.4	8.8	9.6	10.6
MP2XLBR0070N120	0.7	1.4	1.05	12	1.34	4.3°	50	4	2	●	1	12.6	13.1	14.4	15.9
MP2XLBR0070N160	0.7	1.4	1.05	16	1.34	3.5°	50	4	2	●	1	16.8	17.5	19.2	21.2
MP2XLBR0075N030	0.75	1.5	1.1	3	1.44	8.6°	50	4	2	●	1	3.1	3.3	3.6	3.9

* No interference

SOLID END MILLS

SQUARE

BALL

RADIUS

TAPER

BARREL

ROUGHING

MS PLUS END MILLS

MP2XLB

Ball nose, Short cut length, Long neck, 2 flute

(mm)

Order Number	RE	DC	APMX	LU	DN	B2	LF	DCON	Flutes	Stock	Type	Effective length for inclined angle			
												0.5°	1°	2°	3°
MP2XLBR0075N040	0.75	1.5	1.1	4	1.44	7.7°	50	4	2	●	1	4.2	4.4	4.8	5.2
MP2XLBR0075N060	0.75	1.5	1.1	6	1.44	6.3°	50	4	2	●	1	6.3	6.6	7.2	7.9
MP2XLBR0075N060S06	0.75	1.5	1.1	6	1.44	8°	50	6	2	●	1	6.3	6.6	7.2	7.9
MP2XLBR0075N080	0.75	1.5	1.1	8	1.44	5.4°	50	4	2	●	1	8.4	8.8	9.6	10.6
MP2XLBR0075N080S06	0.75	1.5	1.1	8	1.44	7.2°	60	6	2	●	1	8.4	8.8	9.6	10.6
MP2XLBR0075N100	0.75	1.5	1.1	10	1.44	4.7°	50	4	2	●	1	10.5	11.0	12.0	13.2
MP2XLBR0075N100S06	0.75	1.5	1.1	10	1.44	6.5°	60	6	2	●	1	10.5	11.0	12.0	13.2
MP2XLBR0075N120	0.75	1.5	1.1	12	1.44	4.2°	50	4	2	●	1	12.6	13.1	14.4	15.9
MP2XLBR0075N120S06	0.75	1.5	1.1	12	1.44	5.9°	60	6	2	●	1	12.6	13.1	14.4	15.9
MP2XLBR0075N140	0.75	1.5	1.1	14	1.44	3.8°	55	4	2	●	1	14.7	15.3	16.8	18.5
MP2XLBR0075N160	0.75	1.5	1.1	16	1.44	3.4°	55	4	2	●	1	16.8	17.5	19.2	21.2
MP2XLBR0075N160S06	0.75	1.5	1.1	16	1.44	5°	60	6	2	●	1	16.8	17.5	19.2	21.2
MP2XLBR0075N180	0.75	1.5	1.1	18	1.44	3.1°	60	4	2	●	1	18.9	19.7	21.6	23.8
MP2XLBR0075N200	0.75	1.5	1.1	20	1.44	2.9°	60	4	2	●	1	21.0	21.9	23.9	*
MP2XLBR0075N220	0.75	1.5	1.1	22	1.44	2.7°	60	4	2	●	1	23.0	24.0	26.3	*
MP2XLBR0080N080	0.8	1.6	1.2	8	1.54	5.3°	55	4	2	●	1	8.4	8.8	9.6	10.5
MP2XLBR0080N120	0.8	1.6	1.2	12	1.54	4.1°	55	4	2	●	1	12.6	13.1	14.4	15.9
MP2XLBR0080N160	0.8	1.6	1.2	16	1.54	3.3°	55	4	2	●	1	16.8	17.5	19.1	21.2
MP2XLBR0080N200	0.8	1.6	1.2	20	1.54	2.8°	55	4	2	●	1	21.0	21.9	23.9	*
MP2XLBR0090N080	0.9	1.8	1.4	8	1.74	5.1°	55	4	2	●	1	8.4	8.8	9.6	10.5
MP2XLBR0090N120	0.9	1.8	1.4	12	1.74	3.9°	55	4	2	●	1	12.6	13.1	14.3	15.8
MP2XLBR0090N160	0.9	1.8	1.4	16	1.74	3.1°	55	4	2	●	1	16.8	17.5	19.1	21.1
MP2XLBR0090N200	0.9	1.8	1.4	20	1.74	2.6°	55	4	2	●	1	20.9	21.8	23.9	*
MP2XLBR0100N040	1	2	1.5	4	1.94	7.2°	50	4	2	●	1	4.2	4.4	4.7	5.2
MP2XLBR0100N040S06	1	2	1.5	4	1.94	9°	50	6	2	●	1	4.2	4.4	4.7	5.2
MP2XLBR0100N060	1	2	1.5	6	1.94	5.8°	50	4	2	●	1	6.3	6.6	7.1	7.8
MP2XLBR0100N060S06	1	2	1.5	6	1.94	7.8°	50	6	2	●	1	6.3	6.6	7.1	7.8
MP2XLBR0100N080	1	2	1.5	8	1.94	4.8°	50	4	2	●	1	8.4	8.8	9.5	10.5
MP2XLBR0100N080S06	1	2	1.5	8	1.94	6.9°	50	6	2	●	1	8.4	8.8	9.5	10.5
MP2XLBR0100N100	1	2	1.5	10	1.94	4.2°	50	4	2	●	1	10.5	10.9	11.9	13.1
MP2XLBR0100N100S06	1	2	1.5	10	1.94	6.2°	50	6	2	●	1	10.5	10.9	11.9	13.1
MP2XLBR0100N120	1	2	1.5	12	1.94	3.6°	50	4	2	●	1	12.6	13.1	14.3	15.8
MP2XLBR0100N120S06	1	2	1.5	12	1.94	5.6°	60	6	2	●	1	12.6	13.1	14.3	15.8
MP2XLBR0100N140	1	2	1.5	14	1.94	3.2°	55	4	2	●	1	14.7	15.3	16.7	18.4
MP2XLBR0100N140S06	1	2	1.5	14	1.94	5.1°	60	6	2	●	1	14.7	15.3	16.7	18.4
MP2XLBR0100N160	1	2	1.5	16	1.94	2.9°	55	4	2	●	1	16.8	17.5	19.1	*
MP2XLBR0100N160S06	1	2	1.5	16	1.94	4.7°	65	6	2	●	1	16.8	17.5	19.1	21.1
MP2XLBR0100N180	1	2	1.5	18	1.94	2.7°	55	4	2	●	1	18.9	19.7	21.5	*
MP2XLBR0100N180S06	1	2	1.5	18	1.94	4.3°	65	6	2	●	1	18.9	19.7	21.5	23.8
MP2XLBR0100N200	1	2	1.5	20	1.94	2.4°	65	4	2	●	1	20.9	21.8	23.9	*
MP2XLBR0100N200S06	1	2	1.5	20	1.94	4°	65	6	2	●	1	20.9	21.8	23.9	26.4
MP2XLBR0100N220	1	2	1.5	22	1.94	2.3°	65	4	2	●	1	23.0	24.0	26.3	*
MP2XLBR0100N250	1	2	1.5	25	1.94	2°	65	4	2	●	1	26.2	27.3	*	*
MP2XLBR0100N250S06	1	2	1.5	25	1.94	3.5°	90	6	2	●	1	26.2	27.3	29.9	33.0
MP2XLBR0100N300	1	2	1.5	30	1.94	1.7°	80	4	2	●	1	31.4	32.7	*	*
MP2XLBR0100N300S06	1	2	1.5	30	1.94	3°	90	6	2	●	1	31.4	32.7	35.9	*
MP2XLBR0100N350	1	2	1.5	35	1.94	1.5°	80	4	2	●	1	36.6	38.2	*	*
MP2XLBR0100N350S06	1	2	1.5	35	1.94	2.7°	90	6	2	●	1	36.6	38.2	41.8	*
MP2XLBR0100N400	1	2	1.5	40	1.94	1.4°	80	4	2	●	1	41.8	43.6	*	*
MP2XLBR0100N400S06	1	2	1.5	40	1.94	2.4°	90	6	2	●	1	41.8	43.6	47.8	*
MP2XLBR0125N100	1.25	2.5	1.9	10	2.4	3.5°	55	4	2	●	1	10.4	10.8	11.8	12.9
MP2XLBR0125N150	1.25	2.5	1.9	15	2.4	2.5°	55	4	2	●	1	15.6	16.3	17.8	*

* No interference

● : Inventory maintained.

(mm)

Order Number	RE	DC	APMX	LU	DN	B2	LF	DCON	Flutes	Stock	Type	Effective length for inclined angle			
												0.5°	1°	2°	3°
MP2XLBR0125N200	1.25	2.5	1.9	20	2.4	2°	55	4	2	●	1	20.8	21.7	*	*
MP2XLBR0125N250	1.25	2.5	1.9	25	2.4	1.6°	70	4	2	●	1	26.1	27.2	*	*
MP2XLBR0125N300	1.25	2.5	1.9	30	2.4	1.4°	70	4	2	●	1	31.3	32.6	*	*
MP2XLBR0125N350	1.25	2.5	1.9	35	2.4	1.2°	70	4	2	●	1	36.5	38.1	*	*
MP2XLBR0150N060S03	1.5	3	2.3	6	2.9	—	60	3	2	●	1	*	*	*	*
MP2XLBR0150N080	1.5	3	2.3	8	2.9	6.3°	60	6	2	●	1	8.3	8.6	9.3	10.2
MP2XLBR0150N100	1.5	3	2.3	10	2.9	5.5°	60	6	2	●	1	10.4	10.8	11.7	12.9
MP2XLBR0150N120	1.5	3	2.3	12	2.9	4.9°	60	6	2	●	1	12.5	13.0	14.1	15.5
MP2XLBR0150N140	1.5	3	2.3	14	2.9	4.4°	60	6	2	●	1	14.6	15.2	16.5	18.2
MP2XLBR0150N160	1.5	3	2.3	16	2.9	4°	70	6	2	●	1	16.7	17.3	18.9	20.8
MP2XLBR0150N200	1.5	3	2.3	20	2.9	3.4°	70	6	2	●	1	20.8	21.7	23.7	26.1
MP2XLBR0150N250	1.5	3	2.3	25	2.9	2.8°	70	6	2	●	1	26.1	27.2	29.7	*
MP2XLBR0150N300	1.5	3	2.3	30	2.9	2.5°	70	6	2	●	1	31.3	32.6	35.7	*
MP2XLBR0150N350	1.5	3	2.3	35	2.9	2.2°	90	6	2	●	1	36.5	38.0	41.7	*
MP2XLBR0150N400	1.5	3	2.3	40	2.9	1.9°	90	6	2	●	1	41.7	43.5	*	*
MP2XLBR0175N150	1.75	3.5	2.6	15	3.4	3.8°	65	6	2	●	1	15.6	16.2	17.7	19.4
MP2XLBR0175N250	1.75	3.5	2.6	25	3.4	2.5°	65	6	2	●	1	26.0	27.1	29.6	*
MP2XLBR0175N350	1.75	3.5	2.6	35	3.4	1.9°	90	6	2	●	1	36.5	38.0	*	*
MP2XLBR0175N450	1.75	3.5	2.6	45	3.4	1.5°	90	6	2	●	1	46.9	48.9	*	*
MP2XLBR0200N080S04	2	4	3	8	3.9	—	65	4	2	●	2	*	*	*	*
MP2XLBR0200N100	2	4	3	10	3.9	4.5°	65	6	2	●	1	10.4	10.8	11.6	12.7
MP2XLBR0200N120	2	4	3	12	3.9	3.9°	65	6	2	●	1	12.5	12.9	14.0	15.4
MP2XLBR0200N140	2	4	3	14	3.9	3.4°	65	6	2	●	1	14.6	15.1	16.4	18.0
MP2XLBR0200N160	2	4	3	16	3.9	3.1°	70	6	2	●	1	16.6	17.3	18.8	20.7
MP2XLBR0200N200	2	4	3	20	3.9	2.6°	70	6	2	●	1	20.8	21.7	23.6	*
MP2XLBR0200N250	2	4	3	25	3.9	2.1°	70	6	2	●	1	26.0	27.1	29.6	*
MP2XLBR0200N300	2	4	3	30	3.9	1.8°	80	6	2	●	1	31.2	32.6	*	*
MP2XLBR0200N350	2	4	3	35	3.9	1.6°	80	6	2	●	1	36.5	38.0	*	*
MP2XLBR0200N400	2	4	3	40	3.9	1.4°	90	6	2	●	1	41.7	43.5	*	*
MP2XLBR0200N450	2	4	3	45	3.9	1.2°	90	6	2	●	1	46.9	48.9	*	*
MP2XLBR0200N500	2	4	3	50	3.9	1.1°	100	6	2	●	1	52.1	54.3	*	*
MP2XLBR0250N150	2.5	5	3.8	15	4.9	2°	70	6	2	●	1	15.6	16.2	*	*
MP2XLBR0250N200	2.5	5	3.8	20	4.9	1.5°	70	6	2	●	1	20.8	21.6	*	*
MP2XLBR0250N250	2.5	5	3.8	25	4.9	1.2°	70	6	2	●	1	26.0	27.1	*	*
MP2XLBR0250N300	2.5	5	3.8	30	4.9	1°	80	6	2	●	1	31.2	*	*	*
MP2XLBR0250N350	2.5	5	3.8	35	4.9	0.9°	80	6	2	●	1	36.4	*	*	*
MP2XLBR0250N400	2.5	5	3.8	40	4.9	0.8°	90	6	2	●	1	41.7	*	*	*
MP2XLBR0300N200	3	6	6	20	5.85	—	70	6	2	●	2	*	*	*	*
MP2XLBR0300N250	3	6	6	25	5.85	—	70	6	2	●	2	*	*	*	*
MP2XLBR0300N300	3	6	6	30	5.85	—	80	6	2	●	2	*	*	*	*
MP2XLBR0300N400	3	6	6	40	5.85	—	90	6	2	●	2	*	*	*	*
MP2XLBR0300N500	3	6	6	50	5.85	—	100	6	2	●	2	*	*	*	*

* No interference

SOLID END MILLS

SQUARE

BALL

RADIUS

TAPER

BARREL

ROUGHING

MS PLUS END MILLS

MP2XLB

Ball nose, Short cut length, Long neck, 2 flute

CARBIDE

SOLID END MILLS

SQUARE

BALL

RADIUS

TAPER

BARREL

ROUGHING

RECOMMENDED CUTTING CONDITIONS

Work material		P			M			H			N		
		Revolution (min ⁻¹)	Feed rate (mm/min)	Depth of cut ap (mm)	Revolution (min ⁻¹)	Feed rate (mm/min)	Depth of cut ap (mm)	Revolution (min ⁻¹)	Feed rate (mm/min)	Depth of cut ap (mm)	Revolution (min ⁻¹)	Feed rate (mm/min)	Depth of cut ap (mm)
RE (mm)	Neck length LU (mm)	Carbon steel, Alloy steel, Alloy tool steel, Prehardened steel, Precipitation hardening stainless steel			Hardened steel (45—55HRC)			Copper, Copper alloys					
R0.05	0.3	50000	200	0.002	50000	200	0.002	50000	200	0.004			
	0.5	50000	200	0.001	50000	200	0.002	50000	200	0.002			
R0.1	0.5	50000	400	0.003	50000	320	0.003	50000	320	0.006			
	1	50000	400	0.002	50000	320	0.002	50000	320	0.004			
	1.5	40000	300	0.001	40000	240	0.001	40000	240	0.002			
	2	40000	200	0.001	40000	160	0.001	40000	160	0.002			
	2.5	40000	100	0.001	40000	80	0.001	40000	80	0.002			
R0.15	1	50000	600	0.007	50000	480	0.007	50000	480	0.014			
	1.5	50000	600	0.005	50000	480	0.005	50000	480	0.01			
	2	50000	600	0.003	50000	480	0.003	50000	480	0.006			
	2.5	40000	400	0.003	40000	320	0.003	40000	320	0.006			
	3	40000	300	0.002	40000	240	0.002	40000	240	0.004			
	3.5	30000	250	0.002	30000	200	0.002	30000	200	0.004			
R0.2	4	30000	200	0.002	30000	160	0.002	30000	160	0.004			
	1	50000	1800	0.015	50000	1400	0.015	50000	1400	0.03			
	2	50000	1300	0.01	50000	1000	0.01	50000	1000	0.02			
	3	50000	900	0.005	50000	700	0.005	50000	700	0.01			
	4	40000	600	0.004	40000	480	0.004	40000	480	0.008			
	5	40000	400	0.003	40000	320	0.003	40000	320	0.006			
R0.25	6	30000	200	0.002	30000	160	0.002	30000	160	0.004			
	2	50000	2500	0.02	50000	2000	0.02	50000	2000	0.04			
	3	50000	1500	0.015	50000	1200	0.015	50000	1200	0.03			
	4	45000	1200	0.01	45000	950	0.01	45000	950	0.02			
	5	45000	900	0.007	45000	700	0.007	45000	700	0.014			
	6	36000	600	0.006	36000	480	0.006	36000	480	0.012			
	7	32000	400	0.005	32000	320	0.005	32000	320	0.01			
	8	32000	300	0.003	32000	240	0.003	32000	240	0.006			
R0.3	10	26000	200	0.002	26000	160	0.002	26000	160	0.004			
	2	50000	3500	0.03	50000	2800	0.03	50000	2800	0.06			
	3	50000	3500	0.03	50000	2800	0.03	50000	2800	0.06			
	4	44000	2500	0.02	44000	2000	0.02	44000	2000	0.04			
	5	37000	1200	0.01	37000	950	0.01	37000	950	0.02			
	6	37000	1000	0.008	37000	800	0.008	37000	800	0.016			
	7	35000	750	0.008	35000	600	0.008	35000	600	0.016			
	8	35000	600	0.006	35000	480	0.006	35000	480	0.012			
	9	30000	500	0.004	30000	400	0.004	30000	400	0.008			
	10	30000	500	0.003	30000	400	0.003	30000	400	0.006			
	11	22000	300	0.002	22000	240	0.002	22000	240	0.004			
	12	22000	200	0.002	22000	160	0.002	22000	160	0.004			
R0.4	2	50000	4400	0.04	50000	3500	0.04	50000	3500	0.08			
	3	50000	4000	0.04	50000	3200	0.04	50000	3200	0.08			
	4	50000	4000	0.02	50000	3200	0.02	50000	3200	0.04			
	5	35000	2400	0.02	35000	1900	0.02	35000	1900	0.04			
	6	35000	2400	0.02	35000	1900	0.02	35000	1900	0.04			
	7	30000	1500	0.015	30000	1200	0.015	30000	1200	0.03			
	8	30000	1500	0.01	30000	1200	0.01	30000	1200	0.02			
	10	30000	700	0.008	30000	560	0.008	30000	560	0.016			
12	22000	500	0.006	22000	400	0.006	22000	400	0.012				

Depth of cut

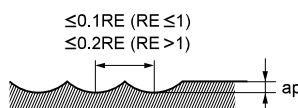

RE:Radius

Note 1) When the inclination angle of machined surface is high, or when machining at high loads; such as in corners, reduce the revolution and feed rate.

Note 2) The use of oil mist is recommended when machining with a small diameter.

Note 3) The revolution and feed rate can be increased at small depths of cut (ap).

Work material		P			M			H			N		
		Carbon steel, Alloy steel, Alloy tool steel, Prehardened steel, Precipitation hardening stainless steel			Hardened steel (45—55HRC)			Copper, Copper alloys					
RE (mm)	Neck length LU (mm)	Revolution (min ⁻¹)	Feed rate (mm/min)	Depth of cut ap (mm)	Revolution (min ⁻¹)	Feed rate (mm/min)	Depth of cut ap (mm)	Revolution (min ⁻¹)	Feed rate (mm/min)	Depth of cut ap (mm)			
R0.5	3	40000	4000	0.05	40000	3200	0.05	40000	3200	0.1			
	4	40000	4000	0.05	40000	3200	0.05	40000	3200	0.1			
	6	35000	3000	0.03	35000	2400	0.03	35000	2400	0.06			
	8	30000	2000	0.02	30000	1600	0.02	30000	1600	0.04			
	10	20000	1000	0.01	20000	800	0.01	20000	800	0.02			
	12	20000	1000	0.01	20000	800	0.01	20000	800	0.02			
	14	18000	600	0.008	18000	480	0.008	18000	480	0.016			
	16	18000	500	0.008	18000	400	0.008	18000	400	0.016			
	18	13000	300	0.005	13000	240	0.005	13000	240	0.01			
20	13000	250	0.005	13000	200	0.005	13000	200	0.01				
R0.6	6	40000	4400	0.04	40000	3500	0.04	40000	3500	0.08			
	8	40000	4000	0.04	40000	3200	0.04	40000	3200	0.08			
	10	27000	1900	0.02	27000	1500	0.02	27000	1500	0.04			
	12	16000	1400	0.02	16000	1100	0.02	16000	1100	0.04			
	18	15000	700	0.008	15000	560	0.008	15000	560	0.016			
	24	11000	300	0.006	11000	240	0.006	11000	240	0.012			
R0.7	8	40000	4000	0.05	40000	3200	0.05	40000	2560	0.1			
	12	26000	2000	0.04	26000	1600	0.04	26000	1280	0.08			
	16	17000	1400	0.03	17000	1120	0.03	17000	896	0.06			
R0.75	6	40000	6000	0.07	36000	4300	0.07	36000	4300	0.14			
	8	40000	6000	0.07	36000	4300	0.07	36000	4300	0.14			
	10	40000	5000	0.06	36000	3600	0.06	36000	3600	0.12			
	12	32000	3400	0.04	29000	2400	0.04	29000	2400	0.08			
	16	15000	1400	0.03	15000	1100	0.03	15000	1100	0.06			
	20	12000	900	0.02	12000	720	0.02	12000	720	0.04			
	30	9000	400	0.01	9000	320	0.01	9000	320	0.02			
R0.8	8	40000	6000	0.08	32000	3800	0.08	32000	3800	0.16			
	12	36000	4500	0.06	29000	2800	0.06	29000	2800	0.12			
	16	14000	1400	0.04	14000	1100	0.04	14000	1100	0.08			
	20	12000	1000	0.03	12000	800	0.03	12000	800	0.06			
R0.9	8	40000	6600	0.09	32000	4200	0.09	32000	4200	0.18			
	12	40000	5000	0.07	32000	3200	0.07	32000	3200	0.14			
	16	28000	2800	0.04	22000	1800	0.04	22000	1800	0.08			
	20	10000	800	0.03	10000	640	0.03	10000	640	0.06			
R1	4	40000	8000	0.1	32000	5000	0.1	32000	5000	0.2			
	6	40000	8000	0.1	32000	5000	0.1	32000	5000	0.2			
	8	40000	6000	0.1	32000	3800	0.1	32000	3800	0.2			
	10	40000	5000	0.08	32000	3200	0.08	32000	3200	0.16			
	12	40000	5000	0.08	32000	3200	0.08	32000	3200	0.16			
	16	32000	3500	0.05	26000	2200	0.05	26000	2200	0.1			
	20	10000	1000	0.04	10000	800	0.04	10000	800	0.08			
	25	10000	1000	0.04	10000	800	0.04	10000	800	0.08			
	30	10000	800	0.02	10000	640	0.02	10000	640	0.04			
	35	10000	600	0.02	10000	480	0.02	10000	480	0.04			
	40	8000	400	0.01	8000	320	0.01	8000	320	0.02			

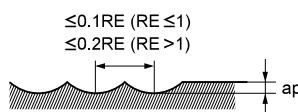

RE:Radius

Note 4) Cutting conditions may differ considerably due to the overhang, depth of cut and machine tool condition. Please use the table above as a reference starting point.

Note 5) For hardened steel over 55HRC, use VF2XLB.

Note 6) For cutting conditions for austenitic stainless steel and titanium alloy, use the high hardness steel (45-55HRC) table but reduce the spindle speed by 40% and the feed rate by 55%.

MS PLUS END MILLS

MP2XLB

Ball nose, Short cut length, Long neck, 2 flute

CARBIDE

SOLID END MILLS

SQUARE

BALL

RADIUS

TAPER

BARREL

ROUGHING

Work material		P			M			H			N		
		Revolution (min ⁻¹)	Feed rate (mm/min)	Depth of cut ap (mm)	Revolution (min ⁻¹)	Feed rate (mm/min)	Depth of cut ap (mm)	Revolution (min ⁻¹)	Feed rate (mm/min)	Depth of cut ap (mm)	Revolution (min ⁻¹)	Feed rate (mm/min)	Depth of cut ap (mm)
RE (mm)	Neck length LU (mm)												
R1.25	10	36000	6000	0.12	29000	3800	0.12	29000	3800	0.24			
	15	32000	4500	0.1	26000	2900	0.1	26000	2900	0.2			
	20	26000	3200	0.07	21000	2000	0.07	21000	2000	0.14			
	25	12000	1400	0.06	8000	720	0.06	8000	720	0.12			
	30	8000	900	0.04	8000	700	0.04	8000	700	0.08			
	35	8000	800	0.02	8000	640	0.02	8000	510	0.04			
R1.5	6	32000	7000	0.15	26000	4500	0.15	22000	3800	0.3			
	10	32000	7000	0.15	26000	4500	0.15	22000	3800	0.3			
	16	32000	5000	0.1	26000	3200	0.1	22000	2700	0.2			
	20	27000	3800	0.1	22000	2400	0.1	22000	2400	0.2			
	25	21000	2700	0.08	17000	1700	0.08	17000	1700	0.16			
	30	10000	700	0.08	6000	560	0.08	6000	560	0.16			
	35	6000	700	0.06	6000	560	0.06	6000	560	0.12			
	40	6000	600	0.04	6000	480	0.04	6000	480	0.08			
R1.75	15	27500	4400	0.13	22000	2800	0.13	18000	2300	0.26			
	25	23000	3600	0.1	18000	2200	0.1	18000	2200	0.2			
	35	10000	1400	0.08	10000	1100	0.08	10000	1100	0.16			
	45	7500	900	0.04	7500	720	0.04	7500	720	0.08			
R2	10	24000	6000	0.2	19000	3800	0.2	16000	3200	0.4			
	20	24000	3800	0.15	19000	2400	0.15	16000	2000	0.3			
	30	20000	3000	0.1	16000	1900	0.1	16000	1900	0.2			
	40	12000	1700	0.1	12000	1400	0.1	12000	1400	0.2			
	50	8000	1000	0.05	8000	800	0.05	8000	800	0.1			
R2.5	20	22000	6000	0.2	18000	3800	0.2	13000	2800	0.4			
	25	22000	4400	0.2	18000	2800	0.2	13000	2000	0.4			
	30	22000	3800	0.15	18000	2400	0.15	13000	1700	0.3			
	40	22000	3600	0.1	18000	2300	0.1	13000	1600	0.2			
R3	20	20000	6000	0.2	16000	3800	0.2	11000	2600	0.4			
	30	20000	6000	0.2	16000	3800	0.2	11000	2600	0.4			
	40	20000	4500	0.15	16000	2800	0.15	11000	2000	0.3			
	50	20000	3000	0.15	16000	1900	0.15	11000	1300	0.3			
Depth of cut		<p style="text-align: right;">RE:Radius</p>											

Note 1) When the inclination angle of machined surface is high, or when machining at high loads; such as in corners, reduce the revolution and feed rate.

Note 2) The use of oil mist is recommended when machining with a small diameter.

Note 3) The revolution and feed rate can be increased at small depths of cut (ap).

Note 4) Cutting conditions may differ considerably due to the overhang, depth of cut and machine tool condition. Please use the table above as a reference starting point.

Note 5) For hardened steel over 55HRC, use VF2XLB.

Note 6) For cutting conditions for austenitic stainless steel and titanium alloy, use the high hardness steel (45-55HRC) table but reduce the spindle speed by 40% and the feed rate by 55%.

MP3XB

Ball nose, Taper neck, 3 flute



Carbon Steel, Alloy Steel, Cast Iron (<30HRC)	Tool Steel, Pre-Hardened Steel, Hardened Steel (≤45HRC)	Hardened Steel (≤55HRC)	Hardened Steel (>55HRC)	Austenitic Stainless Steel	Titanium Alloy, Heat Resistant Alloy	Copper Alloy	Aluminium Alloy
○	○	○		○	○	○	



Effective length for inclined angle

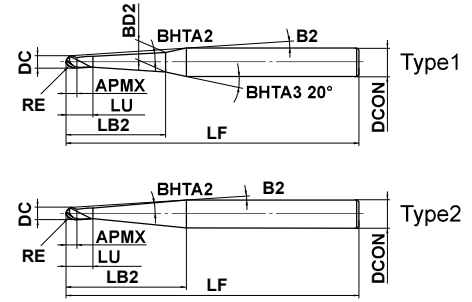
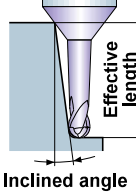

	RE ≤ 3	RE ≥ 4			
	±0.005	±0.010			
	DCON = 6	DCON = 8			
	0 - 0.005	0 - 0.006			
	DCON = 10	DCON ≥ 12			
	0 - 0.009	0 - 0.011			

- Ideal for rough milling of long overhang applications and semi-finishing of forging dies (40-52 HRC).
- Rigid, high helix, 3 flute design enables large depths of cut and high feed rates for increased machining efficiency. (mm)

Order Number	RE	DC	BHTA2	APMX	LB2	LU	B2	BD2	LF	DCON	Flutes	Stock	Type	Effective length for inclined angle			
														0.5°	1°	2°	3°
MP3XBR0050N008T05	0.5	1	0.5°	0.8	8	2.3	9.3°	1.04	60	6	3	●	1	8.5	8.8	9.3	9.8
MP3XBR0050N012T05	0.5	1	0.5°	0.8	12	2.3	7.5°	1.1	60	6	3	●	1	12.6	13	13.6	14.4
MP3XBR0050N016T05	0.5	1	0.5°	0.8	16	2.3	6.3°	1.18	60	6	3	●	1	16.6	17.1	18	18.9
MP3XBR0050N020T05	0.5	1	0.5°	0.8	20	2.3	5.4°	1.24	60	6	3	●	1	20.6	21.2	22.3	23.5
MP3XBR0050N025T05	0.5	1	0.5°	0.8	25	2.3	4.6°	1.34	70	6	3	●	1	25.7	26.3	27.7	29.3
MP3XBR0050N030T05	0.5	1	0.5°	0.8	30	2.3	4°	1.42	70	6	3	●	1	30.7	31.5	33.1	35
MP3XBR0050N050T05	0.5	1	0.5°	0.8	50	2.3	2.6°	1.78	90	6	3	●	1	50.8	52.1	54.8	*
MP3XBR0050N010T10	0.5	1	1°	0.8	10	2.3	8.4°	1.2	60	6	3	●	1	—	10.6	11.2	11.8
MP3XBR0050N016T10	0.5	1	1°	0.8	16	2.3	6.4°	1.42	60	6	3	●	1	—	16.7	17.6	18.5
MP3XBR0050N020T10	0.5	1	1°	0.8	20	2.3	5.5°	1.56	60	6	3	●	1	—	20.7	21.8	23
MP3XBR0050N025T10	0.5	1	1°	0.8	25	2.3	4.7°	1.74	70	6	3	●	1	—	25.7	27.1	28.6
MP3XBR0050N030T10	0.5	1	1°	0.8	30	2.3	4.1°	1.9	70	6	3	●	1	—	30.8	32.4	34.2
MP3XBR0050N035T10	0.5	1	1°	0.8	35	2.3	3.6°	2.08	90	6	3	●	1	—	35.8	37.7	39.8
MP3XBR0050N050T10	0.5	1	1°	0.8	50	2.3	2.7°	2.6	90	6	3	●	1	—	50.9	53.6	*
MP3XBR0050N010T15	0.5	1	1.5°	0.8	10	2.3	8.5°	1.34	60	6	3	●	1	—	—	11	11.6
MP3XBR0050N016T15	0.5	1	1.5°	0.8	16	2.3	6.5°	1.66	60	6	3	●	1	—	—	17.2	18.1
MP3XBR0050N020T15	0.5	1	1.5°	0.8	20	2.3	5.6°	1.86	60	6	3	●	1	—	—	21.3	22.5
MP3XBR0050N023T15	0.5	1	1.5°	0.8	23	2.3	5°	2.02	70	6	3	●	1	—	—	24.4	25.7
MP3XBR0050N025T15	0.5	1	1.5°	0.8	25	2.3	4.7°	2.12	70	6	3	●	1	—	—	26.5	27.9
MP3XBR0050N010T30	0.5	1	3°	0.8	10	2.3	8.8°	1.74	60	6	3	●	1	—	—	—	10.8
MP3XBR0050N020T30	0.5	1	3°	0.8	20	2.3	5.9°	2.8	60	6	3	●	1	—	—	—	20.9
MP3XBR0050N030T30	0.5	1	3°	0.8	30	2.3	4.4°	3.84	70	6	3	●	1	—	—	—	31
MP3XBR0050N042T30	0.5	1	3°	0.8	42	2.3	3.4°	5.1	90	6	3	●	1	—	—	—	43
MP3XBR0050N025T50	0.5	1	5°	0.8	25	2.3	5.4°	4.92	60	6	3	●	1	—	—	—	—
MP3XBR0075N010T05	0.75	1.5	0.5°	1.2	10	2.7	7.8°	1.56	60	6	3	●	1	10.6	10.9	11.4	12
MP3XBR0075N016T05	0.75	1.5	0.5°	1.2	16	2.7	5.8°	1.68	60	6	3	●	1	16.6	17.1	17.9	18.9
MP3XBR0075N020T05	0.75	1.5	0.5°	1.2	20	2.7	5°	1.74	60	6	3	●	1	20.6	21.2	22.3	23.5
MP3XBR0075N030T05	0.75	1.5	0.5°	1.2	30	2.7	3.7°	1.92	80	6	3	●	1	30.7	31.5	33.1	35
MP3XBR0075N010T10	0.75	1.5	1°	1.2	10	2.7	7.9°	1.7	60	6	3	●	1	—	10.6	11.2	11.8
MP3XBR0075N016T10	0.75	1.5	1°	1.2	16	2.7	5.9°	1.9	60	6	3	●	1	—	16.7	17.6	18.5
MP3XBR0075N020T10	0.75	1.5	1°	1.2	20	2.7	5.1°	2.04	60	6	3	●	1	—	20.7	21.8	23
MP3XBR0075N030T10	0.75	1.5	1°	1.2	30	2.7	3.7°	2.4	80	6	3	●	1	—	30.8	32.4	34.2

* No interference

● : Inventory maintained.

SQUARE

BALL

RADIUS

TAPER

BARREL

ROUGHING

SOLID END MILLS

CARBIDE

MS PLUS END MILLS

MP3XB

Ball nose, Taper neck, 3 flute

(mm)

Order Number	RE	DC	BHTA2	APMX	LB2	LU	B2	BD2	LF	DCON	Flutes	Stock	Type	Effective length for inclined angle			
														0.5°	1°	2°	3°
MP3XBR0075N010T15	0.75	1.5	1.5°	1.2	10	2.7	8°	1.82	60	6	3	●	1	—	—	11	11.6
MP3XBR0075N016T15	0.75	1.5	1.5°	1.2	16	2.7	6°	2.14	60	6	3	●	1	—	—	17.2	18.1
MP3XBR0075N020T15	0.75	1.5	1.5°	1.2	20	2.7	5.1°	2.34	60	6	3	●	1	—	—	21.3	22.5
MP3XBR0075N025T15	0.75	1.5	1.5°	1.2	25	2.7	4.4°	2.6	80	6	3	●	1	—	—	26.5	27.9
MP3XBR0075N030T15	0.75	1.5	1.5°	1.2	30	2.7	3.8°	2.86	80	6	3	●	1	—	—	31.6	33.4
MP3XBR0075N046T30	0.75	1.5	3°	1.2	46	2.7	2.9°	—	80	6	3	●	2	—	—	—	*
MP3XBR0100N016T05	1	2	0.5°	1.6	16	3.6	5.2°	2.12	60	6	3	●	1	17	17.6	18.6	19.5
MP3XBR0100N020T05	1	2	0.5°	1.6	20	3.6	4.5°	2.18	60	6	3	●	1	21.1	21.8	22.9	24.1
MP3XBR0100N030T05	1	2	0.5°	1.6	30	3.6	3.3°	2.36	70	6	3	●	1	31.1	32.1	33.7	35.6
MP3XBR0100N035T05	1	2	0.5°	1.6	35	3.6	2.9°	2.44	80	6	3	●	1	36.2	37.2	39.2	*
MP3XBR0100N040T05	1	2	0.5°	1.6	40	3.6	2.6°	2.54	80	6	3	●	1	41.2	42.4	44.6	*
MP3XBR0100N016T10	1	2	1°	1.6	16	3.6	5.3°	2.34	60	6	3	●	1	—	17.1	18.2	19.1
MP3XBR0100N020T10	1	2	1°	1.6	20	3.6	4.5°	2.48	60	6	3	●	1	—	21.2	22.4	23.6
MP3XBR0100N025T10	1	2	1°	1.6	25	3.6	3.8°	2.64	70	6	3	●	1	—	26.2	27.7	29.2
MP3XBR0100N030T10	1	2	1°	1.6	30	3.6	3.3°	2.82	70	6	3	●	1	—	31.3	33	34.8
MP3XBR0100N035T10	1	2	1°	1.6	35	3.6	3°	3	80	6	3	●	1	—	36.3	38.3	40.4
MP3XBR0100N040T10	1	2	1°	1.6	40	3.6	2.7°	3.18	80	6	3	●	1	—	41.3	43.6	*
MP3XBR0100N050T10	1	2	1°	1.6	50	3.6	2.2°	3.52	110	6	3	●	1	—	51.4	54.2	*
MP3XBR0100N070T10	1	2	1°	1.6	70	3.6	1.7°	4.22	110	6	3	●	1	—	71.5	*	*
MP3XBR0100N016T15	1	2	1.5°	1.6	16	3.6	5.4°	2.54	60	6	3	●	1	—	—	22.8	18.7
MP3XBR0100N020T15	1	2	1.5°	1.6	20	3.6	4.6°	2.76	60	6	3	●	1	—	—	21.9	23.1
MP3XBR0100N025T15	1	2	1.5°	1.6	25	3.6	3.9°	3.02	70	6	3	●	1	—	—	27.1	28.5
MP3XBR0100N030T15	1	2	1.5°	1.6	30	3.6	3.4°	3.28	70	6	3	●	1	—	—	32.2	34
MP3XBR0100N035T15	1	2	1.5°	1.6	35	3.6	3°	3.54	80	6	3	●	1	—	—	37.4	39.4
MP3XBR0100N040T15	1	2	1.5°	1.6	40	3.6	2.7°	3.8	80	6	3	●	1	—	—	42.6	*
MP3XBR0100N020T30	1	2	3°	1.6	20	3.6	4.8°	3.62	60	6	3	●	1	—	—	—	20.5
MP3XBR0100N030T30	1	2	3°	1.6	30	3.6	3.6°	4.66	70	6	3	●	1	—	—	—	30.6
MP3XBR0100N042T30	1	2	3°	1.6	42	3.6	2.8°	—	80	6	3	●	2	—	—	—	*
MP3XBR0100N027T50	1	2	5°	1.6	27	3.6	4.3°	—	60	6	3	●	2	—	—	—	—
MP3XBR0150N010T05	1.5	3	0.5°	2.4	10	5.4	5.7°	2.98	60	6	3	●	1	11	11.4	12	12.6
MP3XBR0150N020T05	1.5	3	0.5°	2.4	20	5.4	3.5°	3.16	60	6	3	●	1	21.1	21.8	22.9	24.1
MP3XBR0150N030T05	1.5	3	0.5°	2.4	30	5.4	2.6°	3.32	70	6	3	●	1	31.2	32.1	33.7	*
MP3XBR0150N040T05	1.5	3	0.5°	2.4	40	5.4	2°	3.5	80	6	3	●	1	41.3	42.4	44.6	*
MP3XBR0150N050T05	1.5	3	0.5°	2.4	50	5.4	1.7°	3.68	90	6	3	●	1	51.3	52.7	*	*
MP3XBR0150N020T10	1.5	3	1°	2.4	20	5.4	3.6°	3.4	60	6	3	●	1	—	21.3	22.4	23.6
MP3XBR0150N030T10	1.5	3	1°	2.4	30	5.4	2.6°	3.76	70	6	3	●	1	—	31.3	33	*
MP3XBR0150N035T10	1.5	3	1°	2.4	35	5.4	2.3°	3.94	80	6	3	●	1	—	36.4	38.3	*
MP3XBR0150N040T10	1.5	3	1°	2.4	40	5.4	2.1°	4.1	80	6	3	●	1	—	41.4	43.6	*
MP3XBR0150N050T10	1.5	3	1°	2.4	50	5.4	1.7°	4.46	90	6	3	●	1	—	51.5	*	*
MP3XBR0150N060T10	1.5	3	1°	2.4	60	5.4	1.5°	4.8	110	6	3	●	1	—	61.5	*	*
MP3XBR0150N070T10	1.5	3	1°	2.4	70	5.4	1.3°	5.16	110	6	3	●	1	—	71.6	*	*
MP3XBR0150N020T15	1.5	3	1.5°	2.4	20	5.4	3.7°	3.66	60	6	3	●	1	—	—	22	23.2
MP3XBR0150N030T15	1.5	3	1.5°	2.4	30	5.4	2.7°	4.18	70	6	3	●	1	—	—	32.3	*
MP3XBR0150N035T15	1.5	3	1.5°	2.4	35	5.4	2.4°	4.46	70	6	3	●	1	—	—	37.5	*
MP3XBR0150N040T15	1.5	3	1.5°	2.4	40	5.4	2.1°	4.72	80	6	3	●	1	—	—	42.6	*
MP3XBR0150N045T15	1.5	3	1.5°	2.4	45	5.4	1.9°	4.98	80	6	3	●	1	—	—	*	*
MP3XBR0150N052T15	1.5	3	1.5°	2.4	52	5.4	1.7°	5.34	90	6	3	●	1	—	—	*	*
MP3XBR0150N064T15	1.5	3	1.5°	2.4	64	5.4	1.4°	—	110	6	3	●	2	—	—	*	*
MP3XBR0150N025T30	1.5	3	3°	2.4	25	5.4	3.3°	4.96	60	6	3	●	1	—	—	—	26.8
MP3XBR0150N034T30	1.5	3	3°	2.4	34	5.4	2.6°	—	70	6	3	●	2	—	—	—	*

* No interference

● : Inventory maintained.

(mm)

Order Number	RE	DC	BH2A2	APMX	LB2	LU	B2	BD2	LF	DCON	Flutes	Stock	Type	Effective length for inclined angle			
														0.5°	1°	2°	3°
MP3XBR0150N040T30	1.5	3	3°	2.4	40	5.4	3.4°	6.52	90	8	3	●	1	—	—	—	41.9
MP3XBR0150N054T30	1.5	3	3°	2.4	54	5.4	2.7°	—	90	8	3	●	2	—	—	—	*
MP3XBR0200N030T05	2	4	0.5°	3.2	30	6.2	1.8°	4.32	70	6	3	●	1	31.2	32.1	*	*
MP3XBR0200N040T05	2	4	0.5°	3.2	40	6.2	1.4°	4.48	80	6	3	●	1	41.3	42.4	*	*
MP3XBR0200N060T05	2	4	0.5°	3.2	60	6.2	1°	4.84	100	6	3	●	1	61.4	63	*	*
MP3XBR0200N020T10	2	4	1°	3.2	20	6.2	2.6°	4.38	70	6	3	●	1	—	21.3	22.4	*
MP3XBR0200N030T10	2	4	1°	3.2	30	6.2	1.8°	4.74	70	6	3	●	1	—	31.4	*	*
MP3XBR0200N035T10	2	4	1°	3.2	35	6.2	1.6°	4.9	70	6	3	●	1	—	36.4	*	*
MP3XBR0200N040T10	2	4	1°	3.2	40	6.2	1.5°	5.08	80	6	3	●	1	—	41.4	*	*
MP3XBR0200N045T10	2	4	1°	3.2	45	6.2	1.3°	5.26	80	6	3	●	1	—	46.5	*	*
MP3XBR0200N066T10	2	4	1°	3.2	66	6.2	1°	—	100	6	3	●	2	—	*	*	*
MP3XBR0200N050T15	2	4	1.5°	3.2	50	6.2	2.2°	6.2	90	8	3	●	1	—	—	53	*
MP3XBR0200N084T15	2	4	1.5°	3.2	84	6.2	1.5°	—	120	8	3	●	2	—	—	*	*
MP3XBR0200N030T30	2	4	3°	3.2	30	6.2	3.6°	6.4	90	8	3	●	1	—	—	—	31.9
MP3XBR0200N045T30	2	4	3°	3.2	45	6.2	2.6°	—	90	8	3	●	2	—	—	—	*
MP3XBR0250N038T10	2.5	5	1°	4	38	7	0.8°	—	80	6	3	●	2	—	*	*	*
MP3XBR0250N050T10	2.5	5	1°	4	50	7	1.7°	6.4	90	8	3	●	1	—	51.5	*	*
MP3XBR0250N065T10	2.5	5	1°	4	65	7	1.4°	6.92	110	8	3	●	1	—	66.6	*	*
MP3XBR0250N066T15	2.5	5	1.5°	4	66	7	1.4°	—	110	8	3	●	2	—	—	*	*
MP3XBR0250N036T30	2.5	5	3°	4	36	7	2.4°	—	90	8	3	●	2	—	—	—	*
MP3XBR0300N040T10	3	6	1°	9	40	12	1.4°	6.82	80	8	3	●	1	—	41.8	*	*
MP3XBR0300N050T10	3	6	1°	9	50	12	1.2°	7.18	90	8	3	●	1	—	51.8	*	*
MP3XBR0300N073T10	3	6	1°	9	73	12	0.9°	—	110	8	3	●	2	—	*	*	*
MP3XBR0300N090T10	3	6	1°	9	90	12	1.3°	8.58	140	10	3	●	1	—	92	*	*
MP3XBR0300N053T15	3	6	1.5°	9	53	12	1.2°	—	90	8	3	●	2	—	—	*	*
MP3XBR0300N032T30	3	6	3°	9	32	12	1.9°	—	80	8	3	●	2	—	—	—	*
MP3XBR0400N050T10	4	8	1°	12	50	15	1.2°	9.08	110	10	3	●	1	—	51.9	*	*
MP3XBR0400N065T10	4	8	1°	12	65	15	1°	9.6	130	10	3	●	1	—	67	*	*
MP3XBR0400N076T10	4	8	1°	12	76	15	0.8°	—	130	10	3	●	2	—	*	*	*
MP3XBR0400N090T10	4	8	1°	12	90	15	1.3°	10.46	150	12	3	●	1	—	92.1	*	*
MP3XBR0400N040T15	4	8	1.5°	12	40	15	1.5°	9.16	90	10	3	●	1	—	—	*	*
MP3XBR0400N056T15	4	8	1.5°	12	56	15	1.1°	—	110	10	3	●	2	—	—	*	*
MP3XBR0400N035T30	4	8	3°	12	35	15	1.7°	—	90	10	3	●	2	—	—	—	*
MP3XBR0500N060T10	5	10	1°	15	60	25	1°	10.92	120	12	3	●	1	—	62.6	*	*
MP3XBR0500N070T10	5	10	1°	15	70	25	0.9°	11.28	120	12	3	●	1	—	*	*	*
MP3XBR0500N100T10	5	10	1°	15	100	25	1.7°	12.32	160	16	3	●	1	—	102.8	*	*
MP3XBR0500N050T15	5	10	1.5°	15	50	25	1.2°	11	100	12	3	●	1	—	—	*	*
MP3XBR0500N068T15	5	10	1.5°	15	68	25	0.9°	—	120	12	3	●	2	—	—	*	*
MP3XBR0500N046T30	5	10	3°	15	46	25	1.3°	—	100	12	3	●	2	—	—	—	*
MP3XBR0600N070T10	6	12	1°	18	70	28	1.6°	13.16	130	16	3	●	1	—	72.7	*	*
MP3XBR0600N100T10	6	12	1°	18	100	28	1.2°	14.22	160	16	3	●	1	—	102.9	*	*
MP3XBR0600N080T15	6	12	1.5°	18	80	28	1.5°	14.42	130	16	3	●	1	—	—	*	*
MP3XBR0600N069T30	6	12	3°	18	69	28	1.8°	—	130	16	3	●	2	—	—	—	*

* No interference

SOLID END MILLS

SQUARE

BALL

RADIUS

TAPER

BARREL

ROUGHING

MS PLUS END MILLS

MP3XB

Ball nose, Taper neck, 3 flute,

CARBIDE

RECOMMENDED CUTTING CONDITIONS

Work material			P				H				N				
			Carbon steel, Cast iron (180–280HB) Tool steel ($\leq 350\text{HB}$) Pre-hardened steel (35–45HRC)				Hardened steel (45–52HRC)				Copper, Copper alloys				
RE (mm)	Taper angle one side BHTA2	Neck length LB2 (mm)	Revolution (min^{-1})	Feed rate (mm/min)	Depth of cut a_p (mm)	Depth of cut a_e (mm)	Revolution (min^{-1})	Feed rate (mm/min)	Depth of cut a_p (mm)	Depth of cut a_e (mm)	Revolution (min^{-1})	Feed rate (mm/min)	Depth of cut a_p (mm)	Depth of cut a_e (mm)	
R0.5	0.5°	8	40000	1200	0.07	0.22	39000	1200	0.06	0.19	39000	1200	0.12	0.38	
		12	40000	1200	0.06	0.19	39000	1200	0.05	0.16	39000	1200	0.1	0.32	
		16	35000	1100	0.06	0.18	33000	900	0.04	0.14	33000	900	0.09	0.29	
		20	32000	960	0.05	0.14	29000	800	0.04	0.11	29000	800	0.07	0.22	
		25	28000	830	0.03	0.11	24000	600	0.02	0.07	24000	600	0.05	0.15	
		30	24000	720	0.03	0.1	21000	450	0.02	0.06	21000	450	0.04	0.13	
		50	10000	300	0.003	0.015	11000	150	0.003	0.015	11000	150	0.006	0.019	
	1°	10	40000	1200	0.07	0.22	39000	1300	0.06	0.19	39000	1300	0.12	0.38	
		16	35000	1100	0.06	0.18	33000	1000	0.05	0.14	33000	1000	0.09	0.29	
		20	32000	960	0.05	0.14	29000	900	0.04	0.11	29000	900	0.07	0.22	
		25	28000	830	0.04	0.11	24000	700	0.03	0.08	24000	700	0.05	0.16	
		30	24000	720	0.03	0.1	21000	550	0.02	0.06	21000	550	0.04	0.13	
		35	17000	500	0.03	0.08	13000	350	0.02	0.05	13000	350	0.03	0.1	
		50	10000	300	0.003	0.015	11000	250	0.003	0.015	11000	250	0.006	0.019	
	1.5°	10	40000	1200	0.07	0.22	39000	1400	0.06	0.19	39000	1400	0.12	0.38	
		16	35000	1100	0.06	0.18	33000	1100	0.05	0.14	33000	1100	0.09	0.29	
		20	32000	960	0.05	0.14	29000	1000	0.04	0.11	29000	1000	0.07	0.22	
		23	27000	830	0.04	0.11	24000	800	0.03	0.08	24000	800	0.05	0.16	
		25	27000	830	0.04	0.12	24000	800	0.03	0.09	24000	800	0.05	0.17	
	3°	10	40000	1200	0.07	0.22	39000	1500	0.06	0.19	39000	1500	0.12	0.38	
		20	32000	960	0.05	0.14	29000	1100	0.04	0.11	29000	1100	0.07	0.22	
		30	22000	660	0.03	0.1	19000	700	0.02	0.06	19000	700	0.04	0.13	
		42	13000	390	0.005	0.02	11000	390	0.005	0.02	11000	390	0.01	0.03	
	5°	25	32000	960	0.04	0.11	29000	1000	0.03	0.08	29000	1000	0.05	0.16	
	R0.75	0.5°	10	30000	1800	0.11	0.34	28000	1500	0.1	0.3	28000	1500	0.19	0.61
			16	27000	1600	0.09	0.27	24000	1100	0.08	0.24	24000	1100	0.15	0.48
			20	26000	1500	0.08	0.24	24000	1100	0.07	0.21	24000	1100	0.13	0.42
			30	25000	1400	0.07	0.21	22000	1000	0.06	0.18	22000	1000	0.11	0.35
1°		10	30000	1900	0.11	0.34	28000	1600	0.1	0.3	28000	1600	0.19	0.61	
		16	26000	1600	0.09	0.27	24000	1200	0.08	0.24	24000	1200	0.15	0.48	
		20	27000	1700	0.08	0.24	24000	1200	0.07	0.21	24000	1200	0.13	0.42	
		30	25000	1500	0.07	0.21	22000	1100	0.06	0.18	22000	1100	0.11	0.35	
1.5°		10	30000	1900	0.11	0.34	28000	1700	0.1	0.3	28000	1700	0.19	0.61	
		16	27500	1700	0.09	0.27	24000	1300	0.08	0.24	24000	1300	0.15	0.48	
		20	26500	1700	0.08	0.24	24000	1300	0.07	0.21	24000	1300	0.13	0.42	
		25	26000	1600	0.07	0.22	23000	1200	0.06	0.19	23000	1200	0.12	0.38	
		30	25000	1500	0.07	0.21	22000	1100	0.06	0.18	22000	1100	0.11	0.35	
3°		46	15000	450	0.05	0.16	14000	800	0.04	0.13	14000	800	0.08	0.26	

Depth of cut

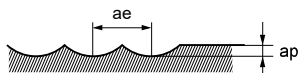

Note 1) If the depth of cut is shallow, the revolution and feed rate can be increased.

Note 2) If the rigidity of the machine or the work materials installation is very low, or chattering and noise are generated, reduce the revolution and feed rate proportionately.

Work material			P				H				N				
			Carbon steel, Cast iron (180–280HB) Tool steel (≤350HB) Pre-hardened steel (35–45HRC)				Hardened steel (45–52HRC)				Copper, Copper alloys				
RE (mm)	Taper angle one side BHTA2	Neck length LB2 (mm)	Revolution (min ⁻¹)	Feed rate (mm/min)	Depth of cut ap (mm)	Depth of cut ae (mm)	Revolution (min ⁻¹)	Feed rate (mm/min)	Depth of cut ap (mm)	Depth of cut ae (mm)	Revolution (min ⁻¹)	Feed rate (mm/min)	Depth of cut ap (mm)	Depth of cut ae (mm)	
R1.0	0.5°	16	25000	1500	0.14	0.45	22000	1600	0.13	0.42	22000	1600	0.26	0.83	
		20	23000	1400	0.1	0.3	20000	1400	0.09	0.27	20000	1400	0.17	0.54	
		30	20000	1200	0.05	0.17	18000	1100	0.06	0.18	18000	1100	0.13	0.42	
		35	19000	1100	0.05	0.15	17000	1000	0.05	0.16	17000	1000	0.12	0.38	
		40	19000	1100	0.04	0.14	16000	900	0.05	0.14	16000	900	0.11	0.35	
	1°	16	25000	2300	0.14	0.45	22000	1700	0.13	0.42	22000	1700	0.26	0.83	
		20	23000	2100	0.1	0.3	20000	1500	0.09	0.27	20000	1500	0.17	0.54	
		25	23000	1400	0.06	0.19	20000	1300	0.07	0.21	20000	1300	0.16	0.5	
		30	20000	1200	0.05	0.17	18000	1200	0.06	0.18	18000	1200	0.13	0.42	
		35	19000	1100	0.05	0.15	17000	1100	0.05	0.15	17000	1100	0.12	0.37	
		40	19000	1100	0.04	0.14	16000	1000	0.05	0.14	16000	1000	0.11	0.35	
		50	17000	900	0.03	0.09	15000	900	0.03	0.08	15000	900	0.06	0.19	
	70	13000	700	0.02	0.06	11000	650	0.02	0.05	11000	650	0.04	0.12		
	1.5°	16	25000	2300	0.14	0.45	22000	1800	0.13	0.42	22000	1800	0.26	0.83	
		20	23000	2100	0.1	0.3	20000	1600	0.09	0.27	20000	1600	0.17	0.54	
		25	23000	1600	0.06	0.19	20000	1400	0.07	0.21	20000	1400	0.16	0.5	
		30	20000	1200	0.05	0.17	18000	1300	0.06	0.18	18000	1300	0.13	0.42	
		35	19000	1100	0.05	0.15	16000	1100	0.05	0.16	17000	1100	0.12	0.38	
		40	19000	1100	0.04	0.14	16000	1000	0.05	0.14	16000	1000	0.11	0.35	
	3°	20	23000	2100	0.1	0.3	20000	1700	0.09	0.27	20000	1700	0.17	0.54	
		30	18000	1600	0.08	0.26	16000	1300	0.07	0.22	16500	1300	0.14	0.45	
		42	16000	1400	0.07	0.21	13000	1000	0.06	0.18	13000	1000	0.11	0.35	
	5°	27	18000	2200	0.09	0.29	17000	1900	0.08	0.26	17000	1900	0.16	0.51	
	R1.5	0.5°	10	20000	2400	0.22	0.7	17000	1900	0.21	0.67	17000	1900	0.42	1.34
			20	17000	2000	0.2	0.64	15000	1600	0.19	0.61	15000	1600	0.38	1.22
			30	16000	1700	0.14	0.45	13000	1400	0.13	0.42	13000	1400	0.26	0.83
			40	16000	1400	0.08	0.24	12000	1200	0.09	0.27	12000	1200	0.2	0.65
50			13000	1100	0.06	0.2	11000	1100	0.07	0.22	11000	1100	0.17	0.54	
1°		20	17000	2000	0.2	0.64	15000	1800	0.19	0.61	15000	1800	0.38	1.22	
		30	17000	1900	0.14	0.45	13000	1500	0.13	0.42	13000	1500	0.26	0.83	
		35	16000	1700	0.08	0.26	13000	1500	0.09	0.29	13000	1500	0.22	0.69	
		40	16000	1500	0.08	0.24	13000	1300	0.09	0.27	13000	1300	0.2	0.65	
		50	13000	1200	0.06	0.2	11000	1100	0.07	0.22	11000	1100	0.17	0.54	
		60	13000	1100	0.06	0.19	11000	1000	0.07	0.21	11000	1000	0.16	0.5	
		70	10000	800	0.05	0.17	9000	700	0.06	0.18	9000	700	0.13	0.42	
1.5°		20	17000	2000	0.2	0.64	15000	1900	0.19	0.61	15000	1900	0.38	1.22	
		30	16000	1800	0.14	0.45	13000	1600	0.13	0.42	13000	1600	0.26	0.83	
		35	15000	1700	0.08	0.26	12000	1400	0.09	0.29	12000	1400	0.22	0.69	
		40	15000	1600	0.08	0.24	12000	1300	0.09	0.27	12000	1300	0.2	0.65	
		45	13000	1400	0.07	0.22	11000	1300	0.08	0.24	11000	1300	0.18	0.58	
		52	13000	1300	0.06	0.2	11000	1100	0.07	0.22	11000	1100	0.17	0.54	
		64	10000	900	0.06	0.18	9000	900	0.06	0.19	9000	900	0.14	0.46	
3°		25	16000	2400	0.16	0.51	13000	1900	0.15	0.48	13000	1900	0.3	0.96	
		34	14000	2100	0.13	0.4	11000	1600	0.12	0.37	11000	1600	0.23	0.74	
		40	14000	1700	0.12	0.37	11000	1400	0.11	0.34	11000	1400	0.21	0.67	
		40	14000	1700	0.12	0.37	11000	1400	0.11	0.34	11000	1400	0.21	0.67	
		54	12000	1400	0.1	0.3	10000	1200	0.09	0.27	10000	1200	0.17	0.54	

I

SOLID END MILLS

SQUARE

BALL

RADIUS

TAPER

BARREL

ROUGHING

Depth of cut

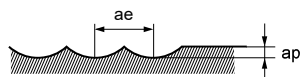

Note 1) If the depth of cut is shallow, the revolution and feed rate can be increased.

Note 2) If the rigidity of the machine or the work materials installation is very low, or chattering and noise are generated, reduce the revolution and feed rate proportionately.

MS PLUS END MILLS

MP3XB

Ball nose, Taper neck, 3 flute

CARBIDE

SOLID END MILLS

SQUARE

BALL

RADIUS

TAPER

BARREL

ROUGHING

Work material			P				H				N			
			Carbon steel, Cast iron (180–280HB) Tool steel ($\leq 350\text{HB}$) Pre-hardened steel (35–45HRC)				Hardened steel (45–52HRC)				Copper, Copper alloys			
RE (mm)	Taper angle one side BHTA2	Neck length LB2 (mm)	Revolution (min ⁻¹)	Feed rate (mm/min)	Depth of cut ap (mm)	Depth of cut ae (mm)	Revolution (min ⁻¹)	Feed rate (mm/min)	Depth of cut ap (mm)	Depth of cut ae (mm)	Revolution (min ⁻¹)	Feed rate (mm/min)	Depth of cut ap (mm)	Depth of cut ae (mm)
R2.0	0.5°	30	14000	2100	0.23	0.74	11000	1800	0.22	0.7	11000	1800	0.44	1.41
		40	12000	1800	0.19	0.61	10000	1600	0.18	0.58	10000	1600	0.36	1.15
		60	9000	1300	0.06	0.19	8500	1400	0.07	0.21	8500	1400	0.16	0.5
	1°	20	15000	2700	0.31	0.99	12000	2200	0.3	0.96	12000	2200	0.72	2.3
		30	14000	2100	0.23	0.74	11000	1800	0.22	0.7	11000	1800	0.53	1.69
		35	12000	1800	0.21	0.67	10000	1700	0.2	0.64	10000	1700	0.48	1.54
		40	12000	1700	0.19	0.61	10000	1600	0.18	0.58	10000	1600	0.43	1.38
		45	12000	1500	0.13	0.42	10000	1600	0.12	0.38	10000	1600	0.29	0.92
	1.5°	66	9000	1100	0.08	0.24	8500	1300	0.07	0.21	8500	1300	0.16	0.5
		50	12000	2200	0.11	0.35	10000	1700	0.1	0.32	10000	1700	0.24	0.77
	3°	84	8000	1400	0.04	0.13	6500	900	0.03	0.1	6500	900	0.07	0.23
		30	14000	2500	0.23	0.74	11000	2000	0.22	0.7	11000	2000	0.53	1.69
		45	11000	1900	0.16	0.51	9000	1600	0.15	0.48	9000	1600	0.36	1.15
R2.5	1°	38	10000	2200	0.28	0.9	8500	2000	0.27	0.86	8500	2000	0.65	2.07
		50	9000	1900	0.24	0.77	8000	1800	0.23	0.74	8000	1800	0.55	1.77
		65	8000	1600	0.16	0.51	6500	1400	0.15	0.48	6500	1400	0.36	1.15
	1.5°	66	8000	1600	0.16	0.51	6500	1500	0.15	0.48	6500	1500	0.36	1.15
	3°	36	10000	2700	0.31	0.99	8500	2300	0.3	0.96	8500	2300	0.72	2.3
R3.0	1°	40	8000	2200	0.28	0.9	7500	2100	0.27	0.86	7500	2100	0.65	2.07
		50	8000	2000	0.23	0.74	6500	1800	0.22	0.7	6500	1800	0.53	1.69
		73	7000	1700	0.15	0.48	6500	1700	0.14	0.45	6500	1700	0.34	1.07
		90	6500	1500	0.09	0.29	6000	1300	0.08	0.26	6000	1300	0.19	0.61
	1.5°	53	7000	2100	0.22	0.7	6500	1900	0.21	0.67	6500	1900	0.5	1.61
	3°	32	9000	2400	0.35	1.12	8000	2200	0.34	1.09	8000	2200	0.82	2.61
R4.0	1°	50	6000	2200	0.41	1.31	5500	2000	0.4	1.28	5500	2000	0.96	3.07
		65	6000	2000	0.36	1.15	5200	1700	0.35	1.12	5200	1700	0.84	2.69
		76	6000	1800	0.29	0.93	5000	1500	0.28	0.9	5000	1500	0.67	2.15
		90	5000	1400	0.19	0.61	4700	1200	0.18	0.58	4700	1200	0.43	1.38
	1.5°	40	6000	2300	0.46	1.47	5800	2200	0.45	1.44	5800	2200	1.08	3.46
		56	6000	2200	0.38	1.22	5500	2000	0.37	1.18	5500	2000	0.9	2.84
	3°	35	7000	2700	0.49	1.57	6000	2400	0.48	1.54	6000	2400	1.15	3.69
R5.0	1°	60	5500	2600	0.51	1.63	4500	2300	0.5	1.6	4500	2300	1.2	3.84
		70	5500	2600	0.46	1.47	4500	2200	0.45	1.44	4500	2200	1.08	3.46
		100	5000	2400	0.36	1.15	4000	1900	0.35	1.12	4000	1900	0.84	2.69
	1.5°	50	5000	2400	0.56	1.79	4600	2400	0.55	1.76	4600	2400	1.32	4.22
		68	5000	2400	0.49	1.57	4600	2300	0.48	1.54	4600	2300	1.15	3.69
	3°	46	5000	2400	0.69	2.21	4800	2500	0.68	2.18	4800	2500	1.63	5.22
R6.0	1°	70	4500	2600	0.81	2.59	4000	2100	0.8	2.56	4000	2100	1.92	6.14
		100	4000	2200	0.61	1.95	3500	1800	0.6	1.92	3500	1800	1.44	4.61
	1.5°	80	5000	2300	0.71	2.27	4000	2000	0.7	2.24	4000	2000	1.68	5.38
	3°	69	5000	2700	0.81	2.59	4000	2200	0.8	2.56	4000	2200	1.92	6.14

Depth of cut

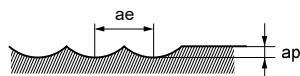

Note 1) If the depth of cut is shallow, the revolution and feed rate can be increased.

Note 2) If the rigidity of the machine or the work materials installation is very low, or chattering and noise are generated, reduce the revolution and feed rate proportionately.

MPSHV/W

End mill, Short cut length, 2.5 x DC neck recess



CARBIDE

Carbon Steel, Alloy Steel, Cast Iron (<30HRC)	Tool Steel, Pre-Hardened Steel, Hardened Steel (≤45HRC)	Hardened Steel (≤55HRC)	Hardened Steel (>55HRC)	Austenitic Stainless Steel	Titanium Alloy, Heat Resistant Alloy	Copper Alloy	Aluminium Alloy
○	○	○	○	○	○	○	○

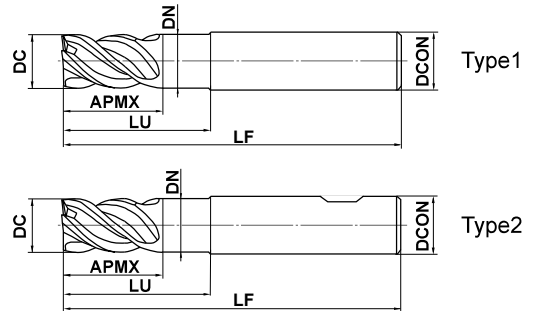

	DC ≤ 12	DC > 12			
	$\begin{matrix} 0 \\ -0.020 \end{matrix}$	$\begin{matrix} 0 \\ -0.030 \end{matrix}$			
	D CON = 6	8 ≤ D CON ≤ 10	12 ≤ D CON ≤ 16	D CON = 20	
	$\begin{matrix} 0 \\ -0.008 \end{matrix}$	$\begin{matrix} 0 \\ -0.009 \end{matrix}$	$\begin{matrix} 0 \\ -0.011 \end{matrix}$	$\begin{matrix} 0 \\ -0.013 \end{matrix}$	

● 4 flute irregular helix with neck recess for reliable HPC / HSC applications

(mm)

Order Number	DC	APMX	LU	DN	LF	D CON	Flutes	Stock	Type
MPSHVD0600N015	6	9	15	5.85	50	6	4	●	1
MPSHVD0600N015W	6	9	15	5.85	50	6	4	●	2
MPSHVD0800N020	8	12	20	7.85	60	8	4	●	1
MPSHVD0800N020W	8	12	20	7.85	60	8	4	●	2
MPSHVD1000N025	10	15	25	9.7	70	10	4	●	1
MPSHVD1000N025W	10	15	25	9.7	70	10	4	●	2
MPSHVD1200N030	12	18	30	11.7	75	12	4	●	1
MPSHVD1200N030W	12	18	30	11.7	75	12	4	●	2
MPSHVD1600N040	16	24	40	15.5	90	16	4	●	1
MPSHVD1600N040W	16	24	40	15.5	90	16	4	●	2
MPSHVD2000N050	20	30	50	19.5	110	20	4	●	1
MPSHVD2000N050W	20	30	50	19.5	110	20	4	●	2

SOLID END MILLS

SQUARE

BALL

RADIUS

TAPER

BARREL

ROUGHING

● : Inventory maintained.

MS PLUS END MILLS

MPSHV/W

End mill, Short cut length, 2.5 x DC neck recess

CARBIDE

SOLID END MILLS

SQUARE

BALL

RADIUS

TAPER

BARREL

ROUGHING

RECOMMENDED CUTTING CONDITIONS

Side milling — High speed cutting conditions (HSC)

Work material	P								M				S		H			
	Carbon steel, Alloy steels (180—280HB), Ductile Cast Iron				Carbon steel, Alloy steels (280—350HB), Pre-hardened steel, Alloy tool steel				Austenitic stainless steels ($\leq 200\text{HB}$), Titanium alloys						Hardened steel (40—52HRC)			
Dia. DC (mm)	Revolution (min ⁻¹)	Feed rate (mm/min)	Depth of cut ap (mm)	Depth of cut ae (mm)	Revolution (min ⁻¹)	Feed rate (mm/min)	Depth of cut ap (mm)	Depth of cut ae (mm)	Revolution (min ⁻¹)	Feed rate (mm/min)	Depth of cut ap (mm)	Depth of cut ae (mm)	Revolution (min ⁻¹)	Feed rate (mm/min)	Depth of cut ap (mm)	Depth of cut ae (mm)		
6	11000	3100	9	0.12	8000	1900	9	0.12	6400	1200	9	0.12	5300	640	9	0.12		
8	8000	2600	12	0.16	6000	1700	12	0.16	4800	1200	12	0.16	4000	640	12	0.16		
10	6400	2600	15	0.2	4800	1600	15	0.2	3800	1100	15	0.2	3200	640	15	0.2		
12	5300	2500	18	0.24	4000	1600	18	0.24	3200	1100	18	0.24	2700	540	18	0.24		
16	4000	1900	24	0.32	3000	1200	24	0.32	2400	860	24	0.32	2000	480	24	0.32		
20	3200	1500	30	0.4	2400	960	30	0.4	1900	680	30	0.4	1600	380	30	0.4		

Depth of cut

Side milling — High depth of cut conditions (HPC)

Work material	P								M				S		H			
	Carbon steel, Alloy steels (180—280HB), Ductile Cast Iron				Carbon steel, Alloy steels (280—350HB), Pre-hardened steel, Alloy tool steel				Austenitic stainless steels ($\leq 200\text{HB}$), Titanium alloys						Hardened steel (40—52HRC)			
Dia. DC (mm)	Revolution (min ⁻¹)	Feed rate (mm/min)	Depth of cut ap (mm)	Depth of cut ae (mm)	Revolution (min ⁻¹)	Feed rate (mm/min)	Depth of cut ap (mm)	Depth of cut ae (mm)	Revolution (min ⁻¹)	Feed rate (mm/min)	Depth of cut ap (mm)	Depth of cut ae (mm)	Revolution (min ⁻¹)	Feed rate (mm/min)	Depth of cut ap (mm)	Depth of cut ae (mm)		
6	8000	2100	9	1.2	6400	1300	9	1.2	5300	1100	9	1.2	3700	440	9	1.2		
8	6000	2000	12	1.6	4800	1400	12	1.6	4000	1100	12	1.6	2800	440	12	1.6		
10	4800	2000	15	2	3800	1400	15	2	3200	1100	15	2	2200	440	15	2		
12	4000	1900	18	2.4	3200	1400	18	2.4	2700	1100	18	2.4	1900	380	18	2.4		
16	3000	1400	24	3.2	2400	1100	24	3.2	2000	840	24	3.2	1400	340	24	3.2		
20	2400	1200	30	4	1900	840	30	4	1600	670	30	4	1100	260	30	4		

Depth of cut

Slotting

Work material	P							M			S		H		
	Carbon steel, Alloy steels (180—280HB), Ductile Cast Iron			Carbon steel, Alloy steels (280—350HB), Pre-hardened steel, Alloy tool steel				Austenitic stainless steels ($\leq 200\text{HB}$), Titanium alloys					Hardened steel (40—52HRC)		
Dia. DC (mm)	Revolution (min ⁻¹)	Feed rate (mm/min)	Depth of cut ap (mm)	Revolution (min ⁻¹)	Feed rate (mm/min)	Depth of cut ap (mm)	Revolution (min ⁻¹)	Feed rate (mm/min)	Depth of cut ap (mm)	Revolution (min ⁻¹)	Feed rate (mm/min)	Depth of cut ap (mm)			
6	6400	860	6	5100	630	6	4200	470	6	1600	190	6			
8	4800	1000	8	3800	750	8	3200	580	8	1200	190	8			
10	3800	910	10	3100	680	10	2500	500	10	950	150	10			
12	3200	910	12	2500	660	12	2100	500	12	800	150	12			
16	2400	690	16	1900	500	16	1600	380	16	600	120	16			
20	1900	550	20	1500	400	20	1300	310	20	450	96	20			

Depth of cut

MPMHV/W

End mill, Medium cut length, 2.5 x DC neck recess



CARBIDE

Carbon Steel, Alloy Steel, Cast Iron (<30HRC)	Tool Steel, Pre-Hardened Steel, Hardened Steel (≤45HRC)	Hardened Steel (≤55HRC)	Hardened Steel (>55HRC)	Austenitic Stainless Steel	Titanium Alloy, Heat Resistant Alloy	Copper Alloy	Aluminium Alloy
○	○	○		○	○	○	

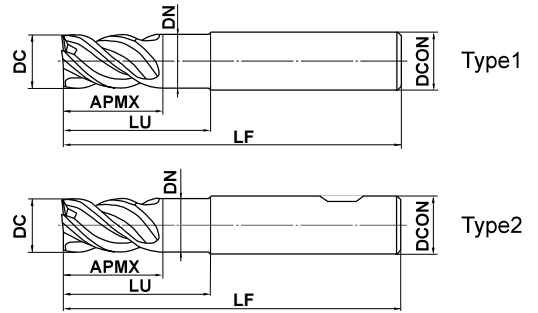

	DC ≤ 12	DC > 12			
	$\begin{matrix} 0 \\ -0.020 \end{matrix}$	$\begin{matrix} 0 \\ -0.030 \end{matrix}$			
	D CON = 6	8 ≤ D CON ≤ 10	12 ≤ D CON ≤ 16	D CON = 20	
	$\begin{matrix} 0 \\ -0.008 \end{matrix}$	$\begin{matrix} 0 \\ -0.009 \end{matrix}$	$\begin{matrix} 0 \\ -0.011 \end{matrix}$	$\begin{matrix} 0 \\ -0.013 \end{matrix}$	

● 4 flute irregular helix with neck recess for reliable HPC / HSC applications

(mm)

Order Number	DC	APMX	LU	DN	LF	D CON	Flutes	Stock	Type
MPMHVD0600N015	6	12	15	5.85	50	6	4	●	1
MPMHVD0600N015W	6	12	15	5.85	50	6	4	●	2
MPMHVD0800N020	8	16	20	7.85	60	8	4	●	1
MPMHVD0800N020W	8	16	20	7.85	60	8	4	●	2
MPMHVD1000N025	10	20	25	9.7	70	10	4	●	1
MPMHVD1000N025W	10	20	25	9.7	70	10	4	●	2
MPMHVD1200N030	12	24	30	11.7	75	12	4	●	1
MPMHVD1200N030W	12	24	30	11.7	75	12	4	●	2
MPMHVD1600N040	16	32	40	15.5	90	16	4	●	1
MPMHVD1600N040W	16	32	40	15.5	90	16	4	●	2
MPMHVD2000N050	20	40	50	19.5	110	20	4	●	1
MPMHVD2000N050W	20	40	50	19.5	110	20	4	●	2

SOLID END MILLS

SQUARE

BALL

RADIUS

TAPER

BARREL

ROUGHING

● : Inventory maintained.

MS PLUS END MILLS

MPMHV/W

End mill, Medium cut length, 2.5 x DC neck recess

CARBIDE

SOLID END MILLS

SQUARE

BALL

RADIUS

TAPER

BARREL

ROUGHING

RECOMMENDED CUTTING CONDITIONS

Side milling — High speed cutting conditions (HSC)

Work material	P								M				S		H			
	Carbon steel, Alloy steels (180—280HB), Ductile Cast Iron				Carbon steel, Alloy steels (280—350HB), Pre-hardened steel, Alloy tool steel				Austenitic stainless steels ($\leq 200\text{HB}$), Titanium alloys				Hardened steel (40—52HRC)					
Dia. DC (mm)	Revolution (min ⁻¹)	Feed rate (mm/min)	Depth of cut ap (mm)	Depth of cut ae (mm)	Revolution (min ⁻¹)	Feed rate (mm/min)	Depth of cut ap (mm)	Depth of cut ae (mm)	Revolution (min ⁻¹)	Feed rate (mm/min)	Depth of cut ap (mm)	Depth of cut ae (mm)	Revolution (min ⁻¹)	Feed rate (mm/min)	Depth of cut ap (mm)	Depth of cut ae (mm)		
6	11000	3100	10	0.12	8000	1900	10	0.12	6400	1200	10	0.12	5300	640	10	0.12		
8	8000	2600	13.5	0.16	6000	1700	13.5	0.16	4800	1200	13.5	0.16	4000	640	13.5	0.16		
10	6400	2600	17	0.2	4800	1600	17	0.2	3800	1100	17	0.2	3200	640	17	0.2		
12	5300	2500	20.5	0.24	4000	1600	20.5	0.24	3200	1100	20.5	0.24	2700	540	20.5	0.24		
16	4000	1900	27.2	0.32	3000	1200	27.2	0.32	2400	860	27.2	0.32	2000	480	27.2	0.32		
20	3200	1500	34	0.4	2400	960	34	0.4	1900	680	34	0.4	1600	380	34	0.4		

Depth of cut

Side milling — High depth of cut conditions (HPC)

Work material	P								M				S		H			
	Carbon steel, Alloy steels (180—280HB), Ductile Cast Iron				Carbon steel, Alloy steels (280—350HB), Pre-hardened steel, Alloy tool steel				Austenitic stainless steels ($\leq 200\text{HB}$), Titanium alloys				Hardened steel (40—52HRC)					
Dia. DC (mm)	Revolution (min ⁻¹)	Feed rate (mm/min)	Depth of cut ap (mm)	Depth of cut ae (mm)	Revolution (min ⁻¹)	Feed rate (mm/min)	Depth of cut ap (mm)	Depth of cut ae (mm)	Revolution (min ⁻¹)	Feed rate (mm/min)	Depth of cut ap (mm)	Depth of cut ae (mm)	Revolution (min ⁻¹)	Feed rate (mm/min)	Depth of cut ap (mm)	Depth of cut ae (mm)		
6	8000	2100	10	1.2	6400	1300	10	1.2	5300	1100	10	1.2	3700	440	10	1.2		
8	6000	2000	13.5	1.6	4800	1400	13.5	1.6	4000	1100	13.5	1.6	2800	440	13.5	1.6		
10	4800	2000	17	2	3800	1400	17	2	3200	1100	17	2	2200	440	17	2		
12	4000	1900	20.5	2.4	3200	1400	20.5	2.4	2700	1100	20.5	2.4	1900	380	20.5	2.4		
16	3000	1400	27.2	3.2	2400	1100	27.2	3.2	2000	840	27.2	3.2	1400	340	27.2	3.2		
20	2400	1200	34	4	1900	840	34	4	1600	670	34	4	1100	260	34	4		

Depth of cut

Slotting

Work material	P							M			S		H		
	Carbon steel, Alloy steels (180—280HB), Ductile Cast Iron				Carbon steel, Alloy steels (280—350HB), Pre-hardened steel, Alloy tool steel			Austenitic stainless steels ($\leq 200\text{HB}$), Titanium alloys			Hardened steel (40—52HRC)				
Dia. DC (mm)	Revolution (min ⁻¹)	Feed rate (mm/min)	Depth of cut ap (mm)	Revolution (min ⁻¹)	Feed rate (mm/min)	Depth of cut ap (mm)	Revolution (min ⁻¹)	Feed rate (mm/min)	Depth of cut ap (mm)	Revolution (min ⁻¹)	Feed rate (mm/min)	Depth of cut ap (mm)			
6	6400	860	6	5100	630	6	4200	470	6	1600	190	6			
8	4800	1000	8	3800	750	8	3200	580	8	1200	190	8			
10	3800	910	10	3100	680	10	2500	500	10	950	150	10			
12	3200	910	12	2500	660	12	2100	500	12	800	150	12			
16	2400	690	16	1900	500	16	1600	380	16	600	120	16			
20	1900	550	20	1500	400	20	1300	310	20	450	96	20			

Depth of cut

MPMHV

End mill, Medium cut length, Irregular helix, 4 flute



CARBIDE

Carbon Steel, Alloy Steel, Cast Iron (<30HRC)	Tool Steel, Pre-Hardened Steel, Hardened Steel (<=45HRC)	Hardened Steel (<=55HRC)	Hardened Steel (>55HRC)	Austenitic Stainless Steel	Titanium Alloy, Heat Resistant Alloy	Copper Alloy	Aluminium Alloy
○	○	○		○	○	○	

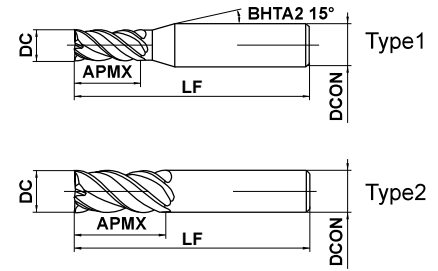

	DC ≤ 12	DC > 12			
	$\begin{matrix} 0 \\ -0.02 \end{matrix}$	$\begin{matrix} 0 \\ -0.03 \end{matrix}$			
	DCON=4	DCON=6	DCON=8		
	$\begin{matrix} 0 \\ -0.005 \end{matrix}$	$\begin{matrix} 0 \\ -0.005 \end{matrix}$	$\begin{matrix} 0 \\ -0.006 \end{matrix}$		
	DCON=6(DC=8)	DCON=8(DC=10)	DCON=10	12 ≤ DCON ≤ 16	DCON=20
	$\begin{matrix} 0 \\ -0.008 \end{matrix}$	$\begin{matrix} 0 \\ -0.009 \end{matrix}$	$\begin{matrix} 0 \\ -0.009 \end{matrix}$	$\begin{matrix} 0 \\ -0.011 \end{matrix}$	$\begin{matrix} 0 \\ -0.013 \end{matrix}$

● 4 flute irregular helix end mill for reduced vibration when machining stainless and carbon steel.

(mm)

Order Number	DC	APMX	LF	DCON	Flutes	Stock	Type
MPMHVD0100	1	2.5	45	4	4	●	1
MPMHVD0150	1.5	3.8	45	4	4	●	1
MPMHVD0200	2	5	45	4	4	●	1
MPMHVD0250	2.5	6.3	45	4	4	●	1
MPMHVD0300	3	7.5	45	6	4	●	1
MPMHVD0400	4	10	45	6	4	●	1
MPMHVD0500	5	12.5	50	6	4	●	1
MPMHVD0600	6	15	60	6	4	●	2
MPMHVD0700	7	17.5	70	8	4	●	2
MPMHVD0800	8	20	70	8	4	●	2
MPMHVD1000	10	25	80	10	4	●	2
MPMHVD1200	12	30	100	12	4	●	2
MPMHVD1600	16	40	110	16	4	●	2
MPMHVD2000	20	50	125	20	4	●	2

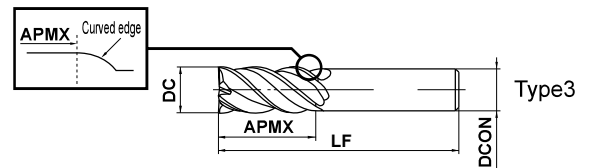

■ Slim Shank

Order Number	DC	APMX	LF	DCON	Flutes	Stock	Type
MPMHVD0700S06	7	17.5	80	6	4	●	3
MPMHVD0800S06	8	20	90	6	4	●	3
MPMHVD0900S08	9	22.5	90	8	4	●	3
MPMHVD1000S08	10	25	100	8	4	●	3
MPMHVD1100S10	11	28	100	10	4	●	3
MPMHVD1200S10	12	30	110	10	4	●	3
MPMHVD1300S12	13	32	110	12	4	●	3
MPMHVD1400S12	14	35	130	12	4	●	3
MPMHVD1800S16	18	45	150	16	4	●	3
MPMHVD2200S20	22	55	160	20	4	●	3

● : Inventory maintained.

SOLID END MILLS

SQUARE

BALL

RADIUS

TAPER

BARREL

ROUGHING

MS PLUS END MILLS

MPMHV

End mill, Medium cut length, Irregular helix, 4 flute

CARBIDE

RECOMMENDED CUTTING CONDITIONS

Side milling

Work material	P								M		S		H			
	Carbon steel, Alloy steel (180—280HB), Ductile Cast Iron				Carbon steel, Alloy steel (280—350HB), Pre-hardened steel, Alloy tool steel				Austenitic stainless steels ($\leq 200\text{HB}$), Titanium alloys		Hardened Steel (45—55HRC)					
Dia. DC (mm)	Revolution (min ⁻¹)	Feed rate (mm/min)	Depth of cut ap (mm)	Depth of cut ae (mm)	Revolution (min ⁻¹)	Feed rate (mm/min)	Depth of cut ap (mm)	Depth of cut ae (mm)	Revolution (min ⁻¹)	Feed rate (mm/min)	Depth of cut ap (mm)	Depth of cut ae (mm)	Revolution (min ⁻¹)	Feed rate (mm/min)	Depth of cut ap (mm)	Depth of cut ae (mm)
1	38000	910	1.7	0.2	31000	500	1.7	0.2	25000	500	1.7	0.2	18000	290	1.7	0.05
1.5	27000	970	2.5	0.3	22000	530	2.5	0.3	18000	500	2.5	0.3	13000	310	2.5	0.08
2	21000	1500	3.5	0.4	17000	820	3.5	0.4	14000	640	3.5	0.4	10000	320	3.5	0.1
2.5	18000	1700	4.2	0.5	15000	900	4.2	0.5	12000	820	4.2	0.5	8500	360	4.2	0.13
3	16000	1800	5	0.6	13000	940	5	0.6	11000	880	5	0.6	7400	380	5	0.15
4	12000	1700	7	0.8	9500	950	7	0.8	8000	900	7	0.8	5600	400	7	0.2
5	9500	1800	8.5	1	7600	1100	8.5	1	6400	900	8.5	1	4500	430	8.5	0.25
6	8000	2100	10	1.2	6400	1300	10	1.2	5300	1100	10	1.2	3700	440	10	0.3
7	6800	2000	12	1.4	5500	1400	12	1.4	4500	1200	12	1.4	3200	450	12	0.35
8	6000	2000	13.5	1.6	4800	1400	13.5	1.6	4000	1200	13.5	1.6	2800	450	13.5	0.4
10	4800	2100	17	2	3800	1500	17	2	3200	1100	17	2	2200	440	17	0.5
12	4000	1900	20.5	2.4	3200	1400	20.5	2.4	2700	1100	20.5	2.4	1900	380	20.5	0.6
16	3000	1400	27.2	3.2	2400	1100	27.2	3.2	2000	840	27.2	3.2	1400	340	27.2	0.8
20	2400	1200	34	4	1900	840	34	4	1600	670	34	4	1100	260	34	1

Note 1) Wet cutting mode is recommended for cutting stainless steels and titanium alloys, and air blow is recommended for carbon steels.
 Note 2) The irregular helix flute end mill has a larger effect on controlling vibration when compared to standard end mills. However, if the rigidity of the machine or the workpiece installation is poor, vibration or abnormal sound can occur. In this case, please reduce the revolution and feed rate proportionately, or set a lower depth of cut.

Side milling (Slim Shank)

Work material	P								M		S		H			
	Carbon steel, Alloy steel (180—280HB), Ductile Cast Iron				Carbon steel, Alloy steel (280—350HB), Pre-hardened steel, Alloy tool steel				Austenitic stainless steel ($\leq 200\text{HB}$), Titanium alloy		Hardened Steel (45—55HRC)					
Dia. DC (mm)	Revolution (min ⁻¹)	Feed rate (mm/min)	Depth of cut ap (mm)	Depth of cut ae (mm)	Revolution (min ⁻¹)	Feed rate (mm/min)	Depth of cut ap (mm)	Depth of cut ae (mm)	Revolution (min ⁻¹)	Feed rate (mm/min)	Depth of cut ap (mm)	Depth of cut ae (mm)	Revolution (min ⁻¹)	Feed rate (mm/min)	Depth of cut ap (mm)	Depth of cut ae (mm)
7	4100	1200	12	0.7	3300	860	12	0.7	2700	700	12	0.7	1900	270	12	0.35
8	3600	1200	13.5	0.8	2900	870	13.5	0.8	2400	720	13.5	0.8	1700	270	13.5	0.4
9	3200	1200	15	0.9	2500	900	15	0.9	2100	660	15	0.9	1500	270	15	0.45
10	2900	1300	17	1	2300	920	17	1	1900	670	17	1	1300	260	17	0.5
11	2600	1200	18.5	1.1	2100	880	18.5	1.1	1700	520	18.5	1.1	1200	190	18.5	0.55
12	2400	1200	20.5	1.2	1900	840	20.5	1.2	1600	650	20.5	1.2	1100	220	20.5	0.6
13	2200	1100	22	1.3	1800	790	22	1.3	1500	490	22	1.3	1000	160	22	0.65
14	2000	960	24	1.4	1600	700	24	1.4	1400	460	24	1.4	950	150	24	0.7
18	1600	770	31	1.8	1300	570	31	1.8	1100	360	31	1.8	740	120	31	0.9
22	1300	620	37.5	2.2	1000	440	37.5	2.2	870	280	37.5	2.2	610	98	37.5	1.2

Note 1) Wet cutting mode is recommended for cutting stainless steels and titanium alloys, and air blow is recommended for carbon steels.
 Note 2) The irregular helix flute end mill has a larger effect on controlling vibration when compared to standard end mills. However, if the rigidity of the machine or the workpiece installation is poor, vibration or abnormal sound can occur. In this case, please reduce the revolution and feed rate proportionately, or set a lower depth of cut.

Slotting

Work material	P						M			S			H		
	Carbon steel, Alloy steel (180—280HB), Ductile Cast Iron			Carbon steel, Alloy steel (280—350HB), Pre-hardened steel, Alloy tool steel			Austenitic stainless steels ($\leq 200\text{HB}$), Titanium alloys			Hardened Steel (45—55HRC)					
Dia. DC (mm)	Revolution (min ⁻¹)	Feed rate (mm/min)	Depth of cut ap (mm)	Revolution (min ⁻¹)	Feed rate (mm/min)	Depth of cut ap (mm)	Revolution (min ⁻¹)	Feed rate (mm/min)	Depth of cut ap (mm)	Revolution (min ⁻¹)	Feed rate (mm/min)	Depth of cut ap (mm)			
1	31000	620	0.5	24000	380	0.5	20000	320	0.5	9500	110	0.2			
1.5	22000	630	0.8	17000	410	0.8	14000	340	0.8	6400	130	0.3			
2	17000	650	2	14000	450	2	11000	350	2	4800	130	0.4			
2.5	15000	830	2.5	12000	580	2.5	9700	470	2.5	3800	130	0.5			
3	13000	940	3	10000	660	3	8500	510	3	3200	140	0.6			
4	9500	820	4	7600	600	4	6400	460	4	2400	150	0.8			
5	7600	910	5	6100	670	5	5100	510	5	1900	170	1			
6	6400	860	6	5100	630	6	4200	470	6	1600	190	1.2			
7	5500	960	7	4400	710	7	3600	530	7	1400	190	1.4			
8	4800	1000	8	3800	750	8	3200	580	8	1200	190	1.6			
10	3800	910	10	3100	680	10	2500	500	10	950	150	2			
12	3200	920	12	2500	660	12	2100	500	12	800	160	2.4			
16	2400	690	16	1900	500	16	1600	380	16	600	120	3.2			
20	1900	550	20	1500	400	20	1300	310	20	480	96	4			

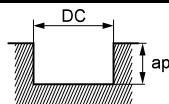

Note 1) Slim shank type is not recommended for slotting.

DC: Dia.

SOLID END MILLS

SQUARE

BALL

RADIUS

TAPER

BARREL

ROUGHING

MS PLUS END MILLS

MPJHV

End mill, Medium cut length, Irregular helix, 4 flute



APMX=DCx3.3 APMX=DCx4

Carbon Steel, Alloy Steel, Cast Iron (<30HRC)	Tool Steel, Pre-Hardened Steel, Hardened Steel (<=45HRC)	Hardened Steel (<=55HRC)	Hardened Steel (>55HRC)	Austenitic Stainless Steel	Titanium Alloy, Heat Resistant Alloy	Copper Alloy	Aluminium Alloy
○	○	○	○	○	○	○	○

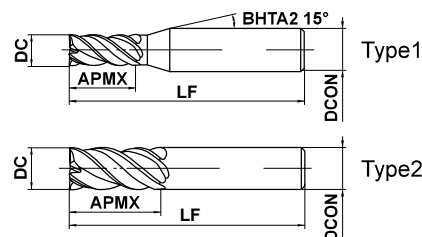

SOLID END MILLS



DC ≤ 12	DC > 12			
0 - 0.02	0 - 0.03			
DCON=4	DCON=6	DCON=8		
0 - 0.005	0 - 0.005	0 - 0.006		
DCON=10	DCON=12	DCON=16	DCON=20	
0 - 0.009	0 - 0.011	0 - 0.11		

- 4 flute irregular helix end mill for reduced vibration when machining stainless and carbon steel.
- Semi long flute length suitable for vertical wall finishing.

(mm)

Order Number	DC	APMX	LF	DCON	Flutes	Stock	Type
MPJHVD0100AP04	1	4	45	4	4	●	1
MPJHVD0150AP06	1.5	6	45	4	4	●	1
MPJHVD0200AP06	2	6.5	60	6	4	●	1
MPJHVD0200AP08	2	8	60	6	4	●	1
MPJHVD0250AP10	2.5	10	60	6	4	●	1
MPJHVD0300AP10	3	10	60	6	4	●	1
MPJHVD0300AP12	3	12	60	6	4	●	1
MPJHVD0400AP13	4	13	60	6	4	●	1
MPJHVD0400AP16	4	16	60	6	4	●	1
MPJHVD0500AP17	5	17	60	6	4	●	1
MPJHVD0500AP20	5	20	60	6	4	●	1
MPJHVD0600AP20	6	20	60	6	4	●	2
MPJHVD0600AP24	6	24	60	6	4	●	2
MPJHVD0800AP26	8	26	80	8	4	●	2
MPJHVD0800AP32	8	32	80	8	4	●	2
MPJHVD1000AP33	10	33	100	10	4	●	2
MPJHVD1000AP40	10	40	100	10	4	●	2
MPJHVD1200AP40	12	40	110	12	4	●	2
MPJHVD1200AP48	12	48	110	12	4	●	2
MPJHVD1600AP53	16	53	125	16	4	●	2
MPJHVD1600AP64	16	64	125	16	4	●	2
MPJHVD2000AP66	20	66	140	20	4	●	2
MPJHVD2000AP80	20	80	140	20	4	●	2

● : Inventory maintained.

SQUARE

BALL

RADIUS

TAPER

BARREL

ROUGHING

RECOMMENDED CUTTING CONDITIONS

■ Side milling

Work material		P								M		S		H			
		Carbon steel, Alloy steel (180—280HB), Ductile Cast Iron				Carbon steel, Alloy steel (280—350HB), Pre-hardened steel, Alloy tool steel				Austenitic stainless steels (≤200HB), Titanium alloys		Hardened Steel (45—55HRC)					
Dia. DC (mm)	Length of Cut APMX(mm)	Revolution (min ⁻¹)	Feed rate (mm/min)	Depth of cut ap (mm)	Depth of cut ae (mm)	Revolution (min ⁻¹)	Feed rate (mm/min)	Depth of cut ap (mm)	Depth of cut ae (mm)	Revolution (min ⁻¹)	Feed rate (mm/min)	Depth of cut ap (mm)	Depth of cut ae (mm)	Revolution (min ⁻¹)	Feed rate (mm/min)	Depth of cut ap (mm)	Depth of cut ae (mm)
1	4	19000	300	3	0.03	15000	240	3	0.03	13000	210	3	0.03	13000	160	3	0.02
1.5	6	16000	320	4.5	0.05	13000	260	4.5	0.05	11000	220	4.5	0.05	8500	170	4.5	0.03
2	6.5	15000	500	5	0.1	12000	380	5	0.1	10000	320	5	0.1	7700	220	5	0.06
2	8	14000	470	6	0.06	11000	350	6	0.06	9500	300	6	0.06	7300	200	6	0.04
2.5	10	13000	660	7.5	0.08	11000	520	7.5	0.08	8900	390	7.5	0.08	6300	250	7.5	0.05
3	10	13000	890	7.4	0.15	10000	620	7.4	0.15	8400	470	7.4	0.15	5900	300	7.4	0.09
3	12	12000	820	9	0.09	9500	590	9	0.09	8000	450	9	0.09	5600	280	9	0.06
4	13	9400	940	9.9	0.2	7500	650	9.9	0.2	6300	530	9.9	0.2	4700	320	9.9	0.12
4	16	9000	900	12	0.12	7200	620	12	0.12	6000	500	12	0.12	4500	310	12	0.08
5	17	7500	990	12.4	0.25	6000	680	12.4	0.25	5000	560	12.4	0.25	3800	350	12.4	0.15
5	20	7200	950	15	0.15	5700	650	15	0.15	4800	540	15	0.15	3600	330	15	0.1
6	20	6300	1100	14.9	0.3	5000	760	14.9	0.3	4200	640	14.9	0.3	3200	350	14.9	0.18
6	24	6000	1000	18	0.18	4800	730	18	0.18	4000	610	18	0.18	3000	330	18	0.12
8	26	4700	1100	19.8	0.4	3800	800	19.8	0.4	3100	620	19.8	0.4	2400	360	19.8	0.24
8	32	4500	1000	24	0.24	3600	760	24	0.24	3000	600	24	0.24	2300	350	24	0.16
10	33	3800	1000	24.8	0.5	3000	760	24.8	0.5	2500	590	24.8	0.5	1900	330	24.8	0.3
10	40	3600	970	30	0.3	2900	730	30	0.3	2400	570	30	0.3	1800	310	30	0.2
12	40	3100	1000	29.7	0.6	2500	720	29.7	0.6	2100	550	29.7	0.6	1600	300	29.7	0.36
12	48	3000	970	36	0.36	2400	690	36	0.36	2000	520	36	0.36	1500	280	36	0.24
16	53	2400	780	27.2	0.48	1900	550	39.6	0.8	1600	420	39.6	0.8	1200	240	39.6	0.48
16	64	2200	710	48	0.48	1800	520	48	0.48	1500	390	48	0.48	1100	220	48	0.32
20	66	1900	620	34	0.6	1500	430	49.5	1	1300	340	49.5	1	950	190	49.5	0.6
20	80	1800	580	60	0.6	1400	400	60	0.6	1200	310	60	0.6	900	180	60	0.4

Depth of cut

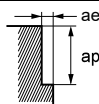

SOLID END MILLS

SQUARE

BALL

RADIUS

TAPER

BARREL

ROUGHING

MS PLUS END MILLS

MP2ES NEW

End mill, For small automatic lathes, 2 flute



Carbon Steel, Alloy Steel, Cast Iron (<30HRC)	Tool Steel, Pre-Hardened Steel, Hardened Steel (≤45HRC)	Hardened Steel (≤55HRC)	Hardened Steel (>55HRC)	Austenitic Stainless Steel	Titanium Alloy, Heat Resistant Alloy	Copper Alloy	Aluminium Alloy
○	○	○	○	○	○	○	○

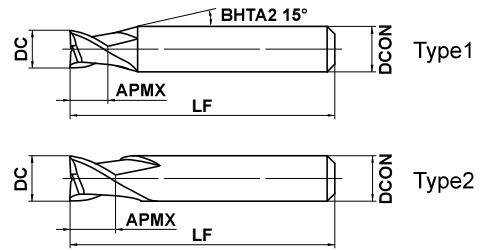

SOLID END MILLS

	3 ≤ DC ≤ 10				
	- 0.010 - 0.030				
	4 ≤ DCON ≤ 6	7 ≤ DCON ≤ 10			
	0 - 0.008	0 - 0.009			

● 2 flute end mill.

(mm)

Order Number	DC	APMX	LF	DCON	Flutes	Stock	Type
MP2ESD0300S04	3	4.5	50	4	2	●	1
MP2ESD0400S04	4	6	50	4	2	●	2
MP2ESD0500S06	5	7.5	50	6	2	●	1
MP2ESD0600S06	6	9	50	6	2	●	2
MP2ESD0700S07	7	10.5	50	7	2	●	2
MP2ESD0800S08	8	12	50	8	2	●	2
MP2ESD1000S10	10	15	50	10	2	●	2

SQUARE

BALL

RADIUS

TAPER

BARREL

ROUGHING

● : Inventory maintained.

RECOMMENDED CUTTING CONDITIONS

■ Side milling

Work material	P				M		S					
	Carbon steel, Cast iron, Alloy steel (–30HRC) AISI 1050, AISI No 35 B, AISI P20				Alloy steel, Tool steel, Pre-hardened steel AISI H13, AISI W1-10, AISI P21		Austenitic stainless steel, Titanium alloy AISI 304, AISI 306, Ti-6Al-4V					
Dia. DC (mm)	Revolution (min ⁻¹)	Feed rate (mm/min)	Depth of Cut ap (mm)	Width of Cut ae (mm)	Revolution (min ⁻¹)	Feed rate (mm/min)	Depth of Cut ap (mm)	Width of Cut ae (mm)	Revolution (min ⁻¹)	Feed rate (mm/min)	Depth of Cut ap (mm)	Width of Cut ae (mm)
3	10000	600	3	0.6	7000	400	3	0.6	6000	300	3	0.6
4	7500	600	4	0.6	5200	400	4	0.6	4500	300	4	0.6
5	6000	600	5	0.6	4200	400	5	0.6	3600	300	5	0.6
6	5000	600	6	0.6	3500	400	6	0.6	3000	300	6	0.6
7	4500	560	7	0.6	3200	360	7	0.6	2700	280	7	0.6
8	4000	520	8	0.6	2800	350	8	0.6	2400	260	8	0.6
10	3200	450	10	0.6	2200	300	10	0.6	1900	230	10	0.6

Depth of cut

Work material	H				N			
	Hardened steel (45–55HRC) AISI H13				Copper, Copper Alloy			
Dia. DC (mm)	Revolution (min ⁻¹)	Feed rate (mm/min)	Depth of Cut ap (mm)	Width of Cut ae (mm)	Revolution (min ⁻¹)	Feed rate (mm/min)	Depth of Cut ap (mm)	Width of Cut ae (mm)
3	5000	120	3	0.2	13000	780	3	0.6
4	4000	120	4	0.2	9500	760	4	0.6
5	3200	120	5	0.2	7600	760	5	0.6
6	2700	120	6	0.2	6400	770	6	0.6
7	2300	110	7	0.2	5500	680	7	0.6
8	2000	110	8	0.2	4800	620	8	0.6
10	1600	100	10	0.2	3800	530	10	0.6

Depth of cut

Note 1) When cutting austenitic stainless steels, the use of water-soluble cutting fluid is effective.

Note 2) If the depth of cut is shallow, the revolution and feed rate can be increased.

Note 3) When drilling, please set the feed rate at 1/3 or below the values above.

Note 4) If the rigidity of the machine or the work materials installation is very low, or chattering and noise are generated, reduce the revolution and feed rate proportionately.

MS PLUS END MILLS

MP2ES NEW

End mill, For small automatic lathes, 2 flute

CARBIDE

RECOMMENDED CUTTING CONDITIONS

■ Slotting

Work material	P			M			S		
	Carbon steel, Cast iron, Alloy steel (–30HRC) AISI 1050, AISI No 35 B, AISI P20			Alloy steel, Tool steel, Pre-hardened steel AISI H13, AISI W1-10, AISI P21			Austenitic stainless steel, Titanium alloy AISI 304, AISI 306, Ti-6Al-4V		
Dia. DC (mm)	Revolution (min ⁻¹)	Feed rate (mm/min)	Depth of Cut ap (mm)	Revolution (min ⁻¹)	Feed rate (mm/min)	Depth of Cut ap (mm)	Revolution (min ⁻¹)	Feed rate (mm/min)	Depth of Cut ap (mm)
3	10000	600	0.6	7000	400	0.6	6000	300	0.6
4	7500	600	0.6	5200	400	0.6	4500	300	0.6
5	6000	600	0.6	4200	400	0.6	3600	300	0.6
6	5000	600	0.6	3500	400	0.6	3000	300	0.6
7	4500	560	0.6	3200	360	0.6	2700	280	0.6
8	4000	520	0.6	2800	350	0.6	2400	260	0.6
10	3200	450	0.6	2200	300	0.6	1900	230	0.6

Depth of cut

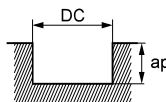

DC: Dia.

Work material	H			N		
	Hardened steel (45–55HRC) AISI H13			Copper, Copper Alloy		
Dia. DC (mm)	Revolution (min ⁻¹)	Feed rate (mm/min)	Depth of Cut ap (mm)	Revolution (min ⁻¹)	Feed rate (mm/min)	Depth of Cut ap (mm)
3	5000	120	0.2	13000	780	0.6
4	4000	120	0.2	9500	760	0.6
5	3200	120	0.2	7600	760	0.6
6	2700	120	0.2	6400	770	0.6
7	2300	110	0.2	5500	680	0.6
8	2000	110	0.2	4800	620	0.6
10	1600	100	0.2	3800	530	0.6

Depth of cut

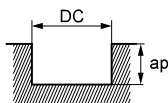

DC: Dia.

Note 1) When cutting austenitic stainless steels, the use of water-soluble cutting fluid is effective.

Note 2) If the depth of cut is shallow, the revolution and feed rate can be increased.

Note 3) When drilling, please set the feed rate at 1/3 or below the values above.

Note 4) If the rigidity of the machine or the work materials installation is very low, or chattering and noise are generated, reduce the revolution and feed rate proportionately.

SOLID END MILLS

SQUARE

BALL

RADIUS

TAPER

BARREL

ROUGHING

MP3ES NEW

End mill, For small automatic lathes, 3 flute



CARBIDE

Carbon Steel, Alloy Steel, Cast Iron (<30HRC)	Tool Steel, Pre-Hardened Steel, Hardened Steel (≤45HRC)	Hardened Steel (≤55HRC)	Hardened Steel (>55HRC)	Austenitic Stainless Steel	Titanium Alloy, Heat Resistant Alloy	Copper Alloy	Aluminium Alloy
○	○	○	○	○	○	○	○

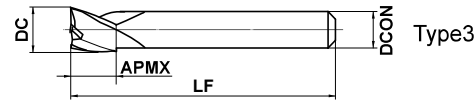
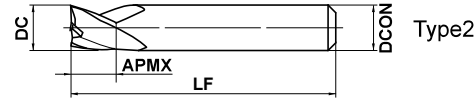
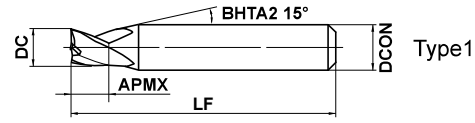

3 ≤ DC ≤ 12				
- 0.010				
- 0.030				
4 ≤ DCON ≤ 6	7 ≤ DCON ≤ 10	DCON = 12		
0	0	0		
- 0.008	- 0.009	- 0.011		

● 3 flute end mill.

(mm)

Order Number	DC	APMX	LF	DCON	Flutes	Stock	Type
MP3ESD0300S04	3	4.5	50	4	3	●	1
MP3ESD0400S04	4	6	50	4	3	●	2
MP3ESD0500S06	5	7.5	50	6	3	●	1
MP3ESD0600S06	6	9	50	6	3	●	2
MP3ESD0700S07	7	10.5	50	7	3	●	2
MP3ESD0800S08	8	12	50	8	3	●	2
MP3ESD0900S10	9	13.5	50	10	3	●	1
MP3ESD1000S10	10	15	50	10	3	●	2
MP3ESD1200S10	12	15	50	10	3	●	3
MP3ESD1200S12	12	15	50	12	3	●	2

SOLID END MILLS

SQUARE

BALL

RADIUS

TAPER

BARREL

ROUGHING

● : Inventory maintained.

MS PLUS END MILLS

MP3ES NEW

End mill, For small automatic lathes, 3 flute

CARBIDE

RECOMMENDED CUTTING CONDITIONS

■ Side milling

Work material	P				M				S					
	Revolution (min ⁻¹)	Feed rate (mm/min)	Depth of Cut ap (mm)	Width of Cut ae (mm)	Revolution (min ⁻¹)	Feed rate (mm/min)	Depth of Cut ap (mm)	Width of Cut ae (mm)	Revolution (min ⁻¹)	Feed rate (mm/min)	Depth of Cut ap (mm)	Width of Cut ae (mm)		
Carbon steel, Cast iron, Alloy steel (-30HRC) AISI 1050, AISI No 35 B, AISI P20					Alloy steel, Tool steel, Pre-hardened steel AISI H13, AISI W1-10, AISI P21					Austenitic stainless steel, Titanium alloy AISI 304, AISI 306, Ti-6Al-4V				
Dia. DC (mm)	Revolution (min ⁻¹)	Feed rate (mm/min)	Depth of Cut ap (mm)	Width of Cut ae (mm)	Revolution (min ⁻¹)	Feed rate (mm/min)	Depth of Cut ap (mm)	Width of Cut ae (mm)	Revolution (min ⁻¹)	Feed rate (mm/min)	Depth of Cut ap (mm)	Width of Cut ae (mm)		
3	10000	720	3	0.6	7000	480	3	0.6	6000	360	3	0.6		
4	7500	720	4	0.6	5200	480	4	0.6	4500	360	4	0.6		
5	6000	720	5	0.6	4200	480	5	0.6	3600	360	5	0.6		
6	5000	720	6	0.6	3500	480	6	0.6	3000	360	6	0.6		
7	4500	670	7	0.6	3200	440	7	0.6	2700	340	7	0.6		
8	4000	620	8	0.6	2800	420	8	0.6	2400	310	8	0.6		
9	3500	580	9	0.6	2500	380	9	0.6	2100	290	9	0.6		
10	3200	540	10	0.6	2200	360	10	0.6	1900	280	10	0.6		
12	2700	490	12	0.6	1900	320	12	0.6	1600	250	12	0.6		

Depth of cut

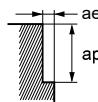

SOLID END MILLS

SQUARE

Work material	H				N				
	Revolution (min ⁻¹)	Feed rate (mm/min)	Depth of Cut ap (mm)	Width of Cut ae (mm)	Revolution (min ⁻¹)	Feed rate (mm/min)	Depth of Cut ap (mm)	Width of Cut ae (mm)	
Hardened steel (45-55HRC) AISI H13					Copper, Copper Alloy				
Dia. DC (mm)	Revolution (min ⁻¹)	Feed rate (mm/min)	Depth of Cut ap (mm)	Width of Cut ae (mm)	Revolution (min ⁻¹)	Feed rate (mm/min)	Depth of Cut ap (mm)	Width of Cut ae (mm)	
3	5000	140	3	0.2	13000	940	3	0.6	
4	4000	140	4	0.2	9500	910	4	0.6	
5	3200	140	5	0.2	7600	910	5	0.6	
6	2700	140	6	0.2	6400	920	6	0.6	
7	2300	130	7	0.2	5500	820	7	0.6	
8	2000	130	8	0.2	4800	740	8	0.6	
9	1800	130	9	0.2	4200	700	9	0.6	
10	1600	120	10	0.2	3800	640	10	0.6	
12	1300	120	12	0.2	3200	580	12	0.6	

Depth of cut

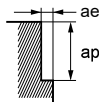

BALL

RADIUS

TAPER

BARREL

ROUGHING

Note 1) When cutting austenitic stainless steels, the use of water-soluble cutting fluid is effective.

Note 2) If the depth of cut is shallow, the revolution and feed rate can be increased.

Note 3) When drilling, please set the feed rate at 1/3 or below the values above.

Note 4) If the rigidity of the machine or the work materials installation is very low, or chattering and noise are generated, reduce the revolution and feed rate proportionately.

Slotting

Work material	P			M			S		
	Carbon steel, Cast iron, Alloy steel (-30HRC) AISI 1050, AISI No 35 B, AISI P20			Alloy steel, Tool steel, Pre-hardened steel AISI H13, AISI W1-10, AISI P21			Austenitic stainless steel, Titanium alloy AISI 304, AISI 306, Ti-6Al-4V		
Dia. DC (mm)	Revolution (min ⁻¹)	Feed rate (mm/min)	Depth of Cut ap (mm)	Revolution (min ⁻¹)	Feed rate (mm/min)	Depth of Cut ap (mm)	Revolution (min ⁻¹)	Feed rate (mm/min)	Depth of Cut ap (mm)
3	10000	720	0.6	7000	480	0.6	6000	360	0.6
4	7500	720	0.6	5200	480	0.6	4500	360	0.6
5	6000	720	0.6	4200	480	0.6	3600	360	0.6
6	5000	720	0.6	3500	480	0.6	3000	360	0.6
7	4500	670	0.6	3200	440	0.6	2700	340	0.6
8	4000	620	0.6	2800	420	0.6	2400	310	0.6
9	3500	580	0.6	2500	380	0.6	2100	290	0.6
10	3200	540	0.6	2200	360	0.6	1900	280	0.6
12	2700	490	0.6	1900	320	0.6	1600	250	0.6

Depth of cut

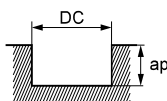

DC: Dia.

Work material	H			N		
	Hardened steel (45-55HRC) AISI H13			Copper, Copper Alloy		
Dia. DC (mm)	Revolution (min ⁻¹)	Feed rate (mm/min)	Depth of Cut ap (mm)	Revolution (min ⁻¹)	Feed rate (mm/min)	Depth of Cut ap (mm)
3	5000	140	0.2	13000	940	0.6
4	4000	140	0.2	9500	910	0.6
5	3200	140	0.2	7600	910	0.6
6	2700	140	0.2	6400	920	0.6
7	2300	130	0.2	5500	820	0.6
8	2000	130	0.2	4800	740	0.6
9	1800	130	0.2	4200	700	0.6
10	1600	120	0.2	3800	640	0.6
12	1300	120	0.2	3200	580	0.6

Depth of cut

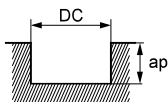

DC: Dia.

Note 1) When cutting austenitic stainless steels, the use of water-soluble cutting fluid is effective.

Note 2) If the depth of cut is shallow, the revolution and feed rate can be increased.

Note 3) When drilling, please set the feed rate at 1/3 or below the values above.

Note 4) If the rigidity of the machine or the work materials installation is very low, or chattering and noise are generated, reduce the revolution and feed rate proportionately.

MS PLUS END MILLS

MP4EC NEW

End mill, For small automatic lathes, 4 flute



Carbon Steel, Alloy Steel, Cast Iron (<30HRC)	Tool Steel, Pre-Hardened Steel, Hardened Steel (≤45HRC)	Hardened Steel (≤55HRC)	Hardened Steel (>55HRC)	Austenitic Stainless Steel	Titanium Alloy, Heat Resistant Alloy	Copper Alloy	Aluminium Alloy
○	○	○		○	○	○	

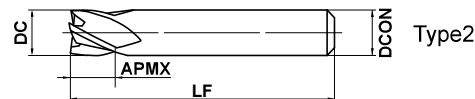
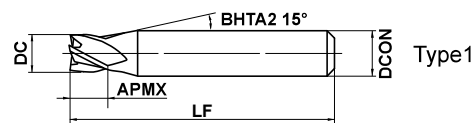

	3 ≤ DC ≤ 12	DC = 14			
	- 0.010 - 0.030	- 0.010 - 0.040			
	4 ≤ DCON ≤ 6	7 ≤ DCON ≤ 10	DCON = 12		
	0 - 0.008	0 - 0.009	0 - 0.011		

● 4 flute end mill.

(mm)

Order Number	DC	APMX	LF	DCON	Flutes	Stock	Type
MP4ECD0300S04	3	4.5	50	4	4	●	1
MP4ECD0350S04	3.5	5	50	4	4	●	1
MP4ECD0400S04	4	6	50	4	4	●	2
MP4ECD0500S06	5	7.5	50	6	4	●	1
MP4ECD0600S06	6	9	50	6	4	●	2
MP4ECD0700S07	7	10.5	50	7	4	●	2
MP4ECD0800S07	8	12	50	7	4	●	3
MP4ECD0800S08	8	12	50	8	4	●	2
MP4ECD0900S10	9	13.5	50	10	4	★	1
MP4ECD1000S07	10	15	50	7	4	●	3
MP4ECD1000S10	10	15	50	10	4	●	2
MP4ECD1200S10	12	15	50	10	4	●	3
MP4ECD1200S12	12	15	50	12	4	★	2
MP4ECD1400S10	14	15	50	10	4	●	3

● : Inventory maintained. ★ : Inventory maintained in Japan.

RECOMMENDED CUTTING CONDITIONS

■ Side milling

Work material	P				M				S			
	Carbon steel, Cast iron, Alloy steel (–30HRC) AISI 1050, AISI No 35 B, AISI P20				Alloy steel, Tool steel, Pre-hardened steel AISI H13, AISI W1-10, AISI P21				Austenitic stainless steel, Titanium alloy AISI 304, AISI 306, Ti-6Al-4V			
Dia. DC (mm)	Revolution (min ⁻¹)	Feed rate (mm/min)	Depth of Cut ap (mm)	Width of Cut ae (mm)	Revolution (min ⁻¹)	Feed rate (mm/min)	Depth of Cut ap (mm)	Width of Cut ae (mm)	Revolution (min ⁻¹)	Feed rate (mm/min)	Depth of Cut ap (mm)	Width of Cut ae (mm)
3	10000	900	3	0.6	7000	600	3	0.6	6000	450	3	0.6
3.5	8500	900	3.5	0.6	6000	600	3.5	0.6	5100	450	3.5	0.6
4	7500	900	4	0.6	5200	600	4	0.6	4500	450	4	0.6
5	6000	900	5	0.6	4200	600	5	0.6	3600	450	5	0.6
6	5000	900	6	0.6	3500	600	6	0.6	3000	450	6	0.6
7	4500	840	7	0.6	3200	540	7	0.6	2700	420	7	0.6
8	4000	780	8	0.6	2800	520	8	0.6	2400	390	8	0.6
9	3500	720	9	0.6	2500	480	9	0.6	2100	360	9	0.6
10	3200	680	10	0.6	2200	450	10	0.6	1900	340	10	0.6
12	2700	620	12	0.6	1900	410	12	0.6	1600	310	12	0.6
14	2300	550	14	0.6	1600	350	14	0.6	1400	280	14	0.6

Depth of cut

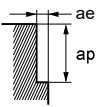

Work material	H				N			
	Hardened steel (45–55HRC) AISI H13				Copper, Copper Alloy			
Dia. DC (mm)	Revolution (min ⁻¹)	Feed rate (mm/min)	Depth of Cut ap (mm)	Width of Cut ae (mm)	Revolution (min ⁻¹)	Feed rate (mm/min)	Depth of Cut ap (mm)	Width of Cut ae (mm)
3	5000	180	3	0.2	13000	1200	3	0.6
3.5	4500	180	3.5	0.2	11000	1200	3.5	0.6
4	4000	180	4	0.2	9500	1100	4	0.6
5	3200	180	5	0.2	7600	1100	5	0.6
6	2700	180	6	0.2	6400	1100	6	0.6
7	2300	160	7	0.2	5500	1000	7	0.6
8	2000	160	8	0.2	4800	940	8	0.6
9	1800	150	9	0.2	4200	860	9	0.6
10	1600	140	10	0.2	3800	810	10	0.6
12	1300	120	12	0.2	3200	730	12	0.6
14	1200	120	14	0.2	2700	650	14	0.6

Depth of cut

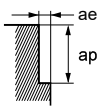

Note 1) When cutting austenitic stainless steels, the use of water-soluble cutting fluid is effective.

Note 2) If the depth of cut is shallow, the revolution and feed rate can be increased.

Note 3) When drilling, please set the feed rate at 1/3 or below the values above.

Note 4) If the rigidity of the machine or the work materials installation is very low, or chattering and noise are generated, reduce the revolution and feed rate proportionately.

MS PLUS END MILLS

MP4EC NEW

End mill, For small automatic lathes, 4 flute

CARBIDE

RECOMMENDED CUTTING CONDITIONS

■ Slotting

Work material	P			M			S			
	Revolution (min ⁻¹)	Feed rate (mm/min)	Depth of Cut ap (mm)	Revolution (min ⁻¹)	Feed rate (mm/min)	Depth of Cut ap (mm)	Revolution (min ⁻¹)	Feed rate (mm/min)	Depth of Cut ap (mm)	
Carbon steel, Cast iron, Alloy steel (-30HRC) AISI 1050, AISI No 35 B, AISI P20				Alloy steel, Tool steel, Pre-hardened steel AISI H13, AISI W1-10, AISI P21			Austenitic stainless steel, Titanium alloy AISI 304, AISI 306, Ti-6Al-4V			
Dia. DC (mm)	Revolution (min ⁻¹)	Feed rate (mm/min)	Depth of Cut ap (mm)	Revolution (min ⁻¹)	Feed rate (mm/min)	Depth of Cut ap (mm)	Revolution (min ⁻¹)	Feed rate (mm/min)	Depth of Cut ap (mm)	
3	10000	900	0.6	7000	600	0.6	6000	450	0.6	
3.5	8500	900	0.6	6000	600	0.6	5100	450	0.6	
4	7500	900	0.6	5200	600	0.6	4500	450	0.6	
5	6000	900	0.6	4200	600	0.6	3600	450	0.6	
6	5000	900	0.6	3500	600	0.6	3000	450	0.6	
7	4500	840	0.6	3200	540	0.6	2700	420	0.6	
8	4000	780	0.6	2800	520	0.6	2400	390	0.6	
9	3500	720	0.6	2500	480	0.6	2100	360	0.6	
10	3200	680	0.6	2200	450	0.6	1900	340	0.6	
12	2700	620	0.6	1900	410	0.6	1600	310	0.6	
14	2300	550	0.6	1600	350	0.6	1400	280	0.6	

Depth of cut

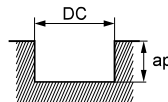

DC: Dia.

Work material	H			N		
	Revolution (min ⁻¹)	Feed rate (mm/min)	Depth of Cut ap (mm)	Revolution (min ⁻¹)	Feed rate (mm/min)	Depth of Cut ap (mm)
Hardened steel (45-55HRC) AISI H13				Copper, Copper Alloy		
Dia. DC (mm)	Revolution (min ⁻¹)	Feed rate (mm/min)	Depth of Cut ap (mm)	Revolution (min ⁻¹)	Feed rate (mm/min)	Depth of Cut ap (mm)
3	5000	180	0.2	13000	1200	0.6
3.5	4500	180	0.2	11000	1200	0.6
4	4000	180	0.2	9500	1100	0.6
5	3200	180	0.2	7600	1100	0.6
6	2700	180	0.2	6400	1100	0.6
7	2300	160	0.2	5500	1000	0.6
8	2000	160	0.2	4800	940	0.6
9	1800	150	0.2	4200	860	0.6
10	1600	140	0.2	3800	810	0.6
12	1300	120	0.2	3200	730	0.6
14	1200	120	0.2	2700	650	0.6

Depth of cut

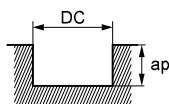

DC: Dia.

Note 1) When cutting austenitic stainless steels, the use of water-soluble cutting fluid is effective.

Note 2) If the depth of cut is shallow, the revolution and feed rate can be increased.

Note 3) When drilling, please set the feed rate at 1/3 or below the values above.

Note 4) If the rigidity of the machine or the work materials installation is very low, or chattering and noise are generated, reduce the revolution and feed rate proportionately.

MPMHVRB

Corner radius, Medium cut length, Irregular helix, 4 flute



CARBIDE

Carbon Steel, Alloy Steel, Cast Iron (<30HRC)	Tool Steel, Pre-Hardened Steel, Hardened Steel (<=45HRC)	Hardened Steel (<=55HRC)	Hardened Steel (>55HRC)	Austenitic Stainless Steel	Titanium Alloy, Heat Resistant Alloy	Copper Alloy	Aluminium Alloy
○	○	○	○	○	○	○	○

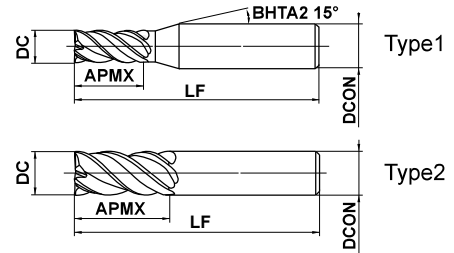

	0.1 ≤ RE ≤ 5				
	± 0.015				
	DC ≤ 12	DC > 12			
	0	0			
	- 0.02	- 0.03			
	DCON=4	DCON=6	DCON=8		
	0	0	0		
	- 0.005	- 0.005	- 0.006		
	DCON=8 (DC=10)	DCON=10 (DC=12)	DCON=10	12 ≤ DCON ≤ 16	DCON=20
	0	0	0	0	0
	- 0.009	- 0.009	- 0.009	- 0.011	- 0.013

● 4 flute irregular helix end mill for reduced vibration when machining stainless and carbon steels.

(mm)

Order Number	DC	RE	APMX	LF	DCON	Flutes	Stock	Type
MPMHVRBD0100R010	1	0.1	2.5	45	4	4	●	1
MPMHVRBD0100R020	1	0.2	2.5	45	4	4	●	1
MPMHVRBD0200R010	2	0.1	5	45	4	4	●	1
MPMHVRBD0200R020	2	0.2	5	45	4	4	●	1
MPMHVRBD0200R030	2	0.3	5	45	4	4	●	1
MPMHVRBD0200R050	2	0.5	5	45	4	4	●	1
MPMHVRBD0300R010	3	0.1	7.5	45	6	4	●	1
MPMHVRBD0300R020	3	0.2	7.5	45	6	4	●	1
MPMHVRBD0300R030	3	0.3	7.5	45	6	4	●	1
MPMHVRBD0300R050	3	0.5	7.5	45	6	4	●	1
MPMHVRBD0400R010	4	0.1	10	45	6	4	●	1
MPMHVRBD0400R020	4	0.2	10	45	6	4	●	1
MPMHVRBD0400R030	4	0.3	10	45	6	4	●	1
MPMHVRBD0400R050	4	0.5	10	45	6	4	●	1
MPMHVRBD0400R100	4	1	10	45	6	4	●	1
MPMHVRBD0500R010	5	0.1	12.5	50	6	4	●	1
MPMHVRBD0500R020	5	0.2	12.5	50	6	4	●	1
MPMHVRBD0500R030	5	0.3	12.5	50	6	4	●	1
MPMHVRBD0500R050	5	0.5	12.5	50	6	4	●	1
MPMHVRBD0500R100	5	1	12.5	50	6	4	●	1
MPMHVRBD0600R010	6	0.1	15	60	6	4	●	2
MPMHVRBD0600R020	6	0.2	15	60	6	4	●	2
MPMHVRBD0600R030	6	0.3	15	60	6	4	●	2
MPMHVRBD0600R050	6	0.5	15	60	6	4	●	2
MPMHVRBD0600R100	6	1	15	60	6	4	●	2
MPMHVRBD0800R020	8	0.2	20	70	8	4	●	2
MPMHVRBD0800R030	8	0.3	20	70	8	4	●	2
MPMHVRBD0800R050	8	0.5	20	70	8	4	●	2
MPMHVRBD0800R100	8	1	20	70	8	4	●	2
MPMHVRBD0800R150	8	1.5	20	70	8	4	●	2
MPMHVRBD0800R200	8	2	20	70	8	4	●	2
MPMHVRBD0800R250	8	2.5	20	70	8	4	●	2

SOLID END MILLS

SQUARE

BALL

RADIUS

TAPER

BARREL

ROUGHING

● : Inventory maintained.

MS PLUS END MILLS

MPMHVRB

Corner radius, Medium cut length, Irregular helix, 4 flute

(mm)

CARBIDE

SOLID END MILLS

SQUARE

BALL

RADIUS

TAPER

BARREL

ROUGHING

Order Number	DC	RE	APMX	LF	DCON	Flutes	Stock	Type
MPMHVRBD0800R300	8	3	20	70	8	4	●	2
MPMHVRBD1000R020	10	0.2	25	80	10	4	●	2
MPMHVRBD1000R030	10	0.3	25	80	10	4	●	2
MPMHVRBD1000R050	10	0.5	25	80	10	4	●	2
MPMHVRBD1000R100	10	1	25	80	10	4	●	2
MPMHVRBD1000R150	10	1.5	25	80	10	4	●	2
MPMHVRBD1000R200	10	2	25	80	10	4	●	2
MPMHVRBD1000R250	10	2.5	25	80	10	4	●	2
MPMHVRBD1000R300	10	3	25	80	10	4	●	2
MPMHVRBD1200R030	12	0.3	30	100	12	4	●	2
MPMHVRBD1200R050	12	0.5	30	100	12	4	●	2
MPMHVRBD1200R100	12	1	30	100	12	4	●	2
MPMHVRBD1200R150	12	1.5	30	100	12	4	●	2
MPMHVRBD1200R200	12	2	30	100	12	4	●	2
MPMHVRBD1200R300	12	3	30	100	12	4	●	2
MPMHVRBD1600R030	16	0.3	40	110	16	4	●	2
MPMHVRBD1600R050	16	0.5	40	110	16	4	●	2
MPMHVRBD1600R100	16	1	40	110	16	4	●	2
MPMHVRBD1600R200	16	2	40	110	16	4	●	2
MPMHVRBD1600R300	16	3	40	110	16	4	●	2
MPMHVRBD1600R500	16	5	40	110	16	4	●	2
MPMHVRBD2000R030	20	0.3	50	125	20	4	●	2
MPMHVRBD2000R050	20	0.5	50	125	20	4	●	2
MPMHVRBD2000R100	20	1	50	125	20	4	●	2
MPMHVRBD2000R200	20	2	50	125	20	4	●	2
MPMHVRBD2000R300	20	3	50	125	20	4	●	2
MPMHVRBD2000R500	20	5	50	125	20	4	●	2

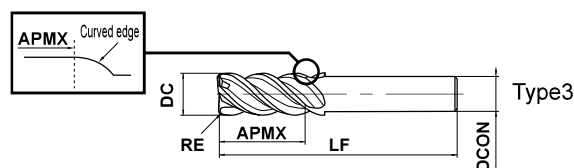

■ Slim Shank

Order Number	DC	RE	APMX	LF	DCON	Flutes	Stock	Type
MPMHVRBD1000R030S08	10	0.3	25	100	8	4	●	3
MPMHVRBD1000R050S08	10	0.5	25	100	8	4	●	3
MPMHVRBD1000R100S08	10	1	25	100	8	4	●	3
MPMHVRBD1000R200S08	10	2	25	100	8	4	●	3
MPMHVRBD1200R030S10	12	0.3	30	110	10	4	●	3
MPMHVRBD1200R050S10	12	0.5	30	110	10	4	●	3
MPMHVRBD1200R100S10	12	1	30	110	10	4	●	3
MPMHVRBD1200R200S10	12	2	30	110	10	4	●	3
MPMHVRBD1200R300S10	12	3	30	110	10	4	●	3

● : Inventory maintained.

RECOMMENDED CUTTING CONDITIONS

Side milling

Work material	P								M				S				H			
	Carbon steel, Alloy steel (280—350HB), Ductile Cast Iron				Carbon steel, Alloy steel (280—350HB), Pre-hardened steel, Alloy tool steel				Austenitic stainless steels ($\leq 200\text{HB}$), Titanium alloys				Hardened Steel (45—55HRC)							
Dia. DC (mm)	Revolution (min ⁻¹)	Feed rate (mm/min)	Depth of cut ap (mm)	Depth of cut ae (mm)	Revolution (min ⁻¹)	Feed rate (mm/min)	Depth of cut ap (mm)	Depth of cut ae (mm)	Revolution (min ⁻¹)	Feed rate (mm/min)	Depth of cut ap (mm)	Depth of cut ae (mm)	Revolution (min ⁻¹)	Feed rate (mm/min)	Depth of cut ap (mm)	Depth of cut ae (mm)				
1	38000	910	1.7	0.2	31000	500	1.7	0.2	25000	500	1.7	0.2	18000	290	1.7	0.05				
2	21000	1500	3.5	0.4	17000	820	3.5	0.4	14000	640	3.5	0.4	10000	320	3.5	0.1				
3	16000	1800	5	0.6	13000	940	5	0.6	11000	880	5	0.6	7400	380	5	0.15				
4	12000	1700	7	0.8	9500	950	7	0.8	8000	900	7	0.8	5600	400	7	0.2				
5	9500	1800	8.5	1	7600	1100	8.5	1	6400	900	8.5	1	4500	430	8.5	0.25				
6	8000	2100	10	1.2	6400	1300	10	1.2	5300	1100	10	1.2	3700	440	10	0.3				
8	6000	2000	13.5	1.6	4800	1400	13.5	1.6	4000	1200	13.5	1.6	2800	450	13.5	0.4				
10	4800	2100	17	2	3800	1500	17	2	3200	1100	17	2	2200	440	17	0.5				
12	4000	1900	20.5	2.4	3200	1400	20.5	2.4	2700	1100	20.5	2.4	1900	380	20.5	0.6				
16	3000	1400	27.2	3.2	2400	1100	27.2	3.2	2000	840	27.2	3.2	1400	340	27.2	0.8				
20	2400	1200	34	4	1900	840	34	4	1600	670	34	4	1100	260	34	1				

Depth of cut



Slotting

Work material	P			M			S			H		
	Carbon steel, Alloy steel (280—350HB), Ductile Cast Iron			Carbon steel, Alloy steel (280—350HB), Pre-hardened steel, Alloy tool steel			Austenitic stainless steels ($\leq 200\text{HB}$), Titanium alloys			Hardened Steel (45—55HRC)		
Dia. DC (mm)	Revolution (min ⁻¹)	Feed rate (mm/min)	Depth of cut ap (mm)	Revolution (min ⁻¹)	Feed rate (mm/min)	Depth of cut ap (mm)	Revolution (min ⁻¹)	Feed rate (mm/min)	Depth of cut ap (mm)	Revolution (min ⁻¹)	Feed rate (mm/min)	Depth of cut ap (mm)
1	31000	620	0.5	24000	380	0.5	20000	400	0.5	9500	110	0.2
2	17000	650	2	14000	450	2	11000	500	2	4800	130	0.4
3	13000	940	3	10000	660	3	8500	680	3	3200	140	0.6
4	9500	820	4	7600	600	4	6400	720	4	2400	150	0.8
5	7600	910	5	6100	670	5	5100	710	5	1900	170	1
6	6400	860	6	5100	630	6	4200	870	6	1600	190	1.2
8	4800	1000	8	3800	750	8	3200	960	8	1200	190	1.6
10	3800	910	10	3100	680	10	2500	880	10	950	150	2
12	3200	920	12	2500	660	12	2100	860	12	800	160	2.4
16	2400	690	16	1900	500	16	1600	380	16	600	120	3.2
20	1900	550	20	1500	400	20	1300	310	20	480	96	4

Depth of cut

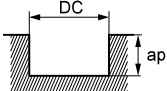

DC: Dia.

SOLID END MILLS

SQUARE

BALL

RADIUS

TAPER

BARREL

ROUGHING

MS PLUS END MILLS

MPXLRB

Corner radius, Short cut length, Long Neck, 2-4 flutes



DC≤0.3

DC≥0.4

Carbon Steel, Alloy Steel, Cast Iron (<30HRC)	Tool Steel, Pre-Hardened Steel, Hardened Steel (≤45HRC)	Hardened Steel (≤55HRC)	Hardened Steel (>55HRC)	Austenitic Stainless Steel	Titanium Alloy, Heat Resistant Alloy	Copper Alloy	Aluminium Alloy
○	○	○		○	○	○	

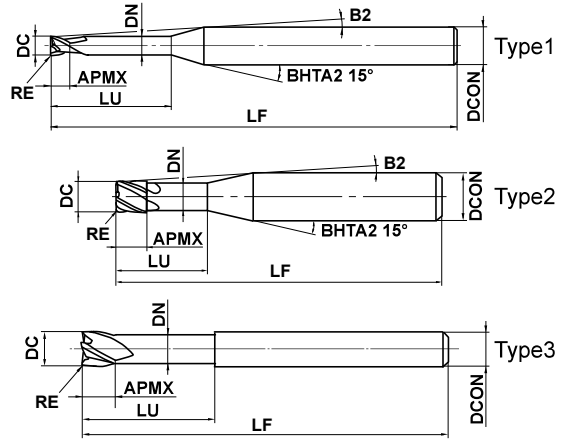

	$0.1 \leq RE \leq 5$
	± 0.005
	$DC \leq 6$
	$0 - 0.01$
	$4 \leq DCON \leq 6$
	$0 - 0.005$

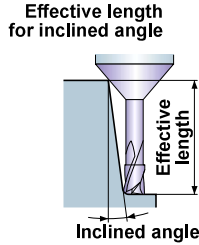

● 2-4 flute irregular helix end mill with corner radius for reduced vibration when machining stainless and carbon steels.

(mm)

Order Number	DC	RE	APMX	LU	DN	B2	LF	DCON	Flutes	Stock	Type	Effective length for inclined angle			
												0.5°	1°	2°	3°
MPXLBD0020R005N005	0.2	0.05	0.2	0.5	0.18	11.4°	50	4	2	●	1	0.5	0.5	0.6	0.7
MPXLBD0020R005N010	0.2	0.05	0.2	1	0.18	10.8°	50	4	2	●	1	1.0	1.1	1.2	1.3
MPXLBD0030R005N010	0.3	0.05	0.3	1	0.28	10.8°	50	4	2	●	1	1.0	1.1	1.2	1.3
MPXLBD0030R005N020	0.3	0.05	0.3	2	0.28	9.8°	50	4	2	●	1	2.1	2.2	2.4	2.7
MPXLBD0040R005N020	0.4	0.05	0.4	2	0.37	9.8°	50	4	4	●	1	2.1	2.2	2.4	2.6
MPXLBD0040R005N030	0.4	0.05	0.4	3	0.37	8.9°	50	4	4	●	1	3.1	3.3	3.6	4.0
MPXLBD0040R005N040	0.4	0.05	0.4	4	0.37	8.2°	50	4	4	●	1	4.2	4.3	4.8	5.3
MPXLBD0050R005N020	0.5	0.05	0.5	2	0.47	9.7°	50	4	4	●	1	2.1	2.2	2.4	2.6
MPXLBD0050R005N030	0.5	0.05	0.5	3	0.47	8.9°	50	4	4	●	1	3.1	3.3	3.6	4.0
MPXLBD0050R005N040	0.5	0.05	0.5	4	0.47	8.1°	50	4	4	●	1	4.2	4.3	4.8	5.3
MPXLBD0050R005N050	0.5	0.05	0.5	5	0.47	7.5°	50	4	4	●	1	5.2	5.4	6.0	6.6
MPXLBD0060R005N020	0.6	0.05	0.6	2	0.57	9.7°	50	4	4	●	1	2.1	2.2	2.4	2.6
MPXLBD0060R005N040	0.6	0.05	0.6	4	0.57	8.1°	50	4	4	●	1	4.2	4.3	4.8	5.3
MPXLBD0060R005N060	0.6	0.05	0.6	6	0.57	6.9°	50	4	4	●	1	6.2	6.5	7.2	7.9
MPXLBD0080R005N040	0.8	0.05	0.8	4	0.77	7.9°	50	4	4	●	1	4.2	4.3	4.8	5.3
MPXLBD0080R005N060	0.8	0.05	0.8	6	0.77	6.8°	50	4	4	●	1	6.2	6.5	7.2	7.9
MPXLBD0100R005N030	1	0.05	1	3	0.96	8.3°	50	4	4	●	1	3.2	3.4	3.8	4.2
MPXLBD0100R005N040	1	0.05	1	4	0.96	7.6°	50	4	4	●	1	4.3	4.5	5.0	5.6
MPXLBD0100R005N050	1	0.05	1	5	0.96	7.0°	50	4	4	●	1	5.4	5.6	6.2	6.9
MPXLBD0100R005N060	1	0.05	1	6	0.96	6.5°	50	4	4	●	1	6.4	6.7	7.4	8.2
MPXLBD0100R005N080	1	0.05	1	8	0.96	5.6°	50	4	4	●	1	8.5	8.9	9.8	10.9
MPXLBD0100R005N100	1	0.05	1	10	0.96	5.0°	50	4	4	●	1	10.6	11.1	12.2	13.5
MPXLBD0100R005N120	1	0.05	1	12	0.96	4.5°	50	4	4	●	1	12.7	13.3	14.6	16.2
MPXLBD0100R010N030	1	0.1	1	3	0.96	8.4°	50	4	4	●	1	3.2	3.4	3.8	4.2
MPXLBD0100R010N040	1	0.1	1	4	0.96	7.6°	50	4	4	●	1	4.3	4.5	5.0	5.5
MPXLBD0100R010N050	1	0.1	1	5	0.96	7.0°	50	4	4	●	1	5.3	5.6	6.2	6.9
MPXLBD0100R010N060	1	0.1	1	6	0.96	6.5°	50	4	4	●	1	6.4	6.7	7.4	8.2
MPXLBD0100R010N080	1	0.1	1	8	0.96	5.6°	50	4	4	●	1	8.5	8.9	9.8	10.8
MPXLBD0100R010N100	1	0.1	1	10	0.96	5.0°	50	4	4	●	1	10.6	11.1	12.2	13.5
MPXLBD0100R010N120	1	0.1	1	12	0.96	4.5°	50	4	4	●	1	12.7	13.3	14.6	16.2
MPXLBD0120R010N100	1.2	0.1	1.2	10	1.16	4.8°	50	4	4	●	1	10.6	11.1	12.2	13.5
MPXLBD0120R020N100	1.2	0.2	1.2	10	1.16	4.8°	50	4	4	●	1	10.6	11.1	12.2	13.5
MPXLBD0150R010N060	1.5	0.1	1.5	6	1.44	6.0°	50	4	4	●	1	6.4	6.7	7.3	8.1
MPXLBD0150R010N120	1.5	0.1	1.5	12	1.44	4.0°	50	4	4	●	1	12.6	13.2	14.5	16.1

● : Inventory maintained.

(mm)

Order Number	DC	RE	APMX	LU	DN	B2	LF	DCON	Flutes	Stock	Type	Effective length for inclined angle			
												0.5°	1°	2°	3°
MPXLRBD0150R010N180	1.5	0.1	1.5	18	1.44	3.0°	60	4	4	●	1	18.9	19.7	21.7	24.0
MPXLRBD0150R020N060	1.5	0.2	1.5	6	1.44	6.0°	50	4	4	●	1	6.4	6.7	7.3	8.1
MPXLRBD0150R020N120	1.5	0.2	1.5	12	1.44	4.0°	50	4	4	●	1	12.6	13.2	14.5	16.0
MPXLRBD0150R020N180	1.5	0.2	1.5	18	1.44	3.0°	60	4	4	●	1	18.9	19.7	21.7	*
MPXLRBD0150R030N060	1.5	0.3	1.5	6	1.44	6.1°	50	4	4	●	1	6.3	6.6	7.3	8.0
MPXLRBD0150R030N120	1.5	0.3	1.5	12	1.44	4.0°	50	4	4	●	1	12.6	13.2	14.5	16.0
MPXLRBD0150R030N180	1.5	0.3	1.5	18	1.44	3.0°	60	4	4	●	1	18.9	19.7	21.6	*
MPXLRBD0200R010N080	2	0.1	2	8	1.94	4.5°	50	4	4	●	1	8.5	8.8	9.7	10.8
MPXLRBD0200R010N120	2	0.1	2	12	1.94	3.4°	50	4	4	●	1	12.6	13.2	14.5	16.1
MPXLRBD0200R010N160	2	0.1	2	16	1.94	2.8°	60	4	4	●	1	16.8	17.6	19.3	*
MPXLRBD0200R010N200	2	0.1	2	20	1.94	2.3°	60	4	4	●	1	21.0	21.9	24.1	*
MPXLRBD0200R010N240	2	0.1	2	24	1.94	2.0°	70	4	4	●	1	25.2	26.3	*	*
MPXLRBD0200R020N080	2	0.2	2	8	1.94	4.5°	50	4	4	●	1	8.5	8.8	9.7	10.7
MPXLRBD0200R020N120	2	0.2	2	12	1.94	3.4°	50	4	4	●	1	12.6	13.2	14.5	*
MPXLRBD0200R020N160	2	0.2	2	16	1.94	2.8°	60	4	4	●	1	16.8	17.6	19.3	*
MPXLRBD0200R020N200	2	0.2	2	20	1.94	2.3°	60	4	4	●	1	21.0	21.9	24.0	*
MPXLRBD0200R020N240	2	0.2	2	24	1.94	2.0°	70	4	4	●	1	25.1	26.3	*	*
MPXLRBD0200R030N080	2	0.3	2	8	1.94	4.5°	50	4	4	●	1	8.5	8.8	9.7	10.7
MPXLRBD0200R030N120	2	0.3	2	12	1.94	3.5°	50	4	4	●	1	12.6	13.2	14.5	16.0
MPXLRBD0200R030N160	2	0.3	2	16	1.94	2.8°	60	4	4	●	1	16.8	17.5	19.2	*
MPXLRBD0200R030N200	2	0.3	2	20	1.94	2.3°	60	4	4	●	1	21.0	21.9	24.0	*
MPXLRBD0200R030N240	2	0.3	2	24	1.94	2.0°	70	4	4	●	1	25.1	26.3	*	*
MPXLRBD0300R010N080	3	0.1	3	8	2.9	5.7°	60	6	4	●	1	8.4	8.8	9.6	10.7
MPXLRBD0300R010N120	3	0.1	3	12	2.9	4.5°	60	6	4	●	1	12.6	13.1	14.4	16.0
MPXLRBD0300R010N180	3	0.1	3	18	2.9	3.4°	70	6	4	●	1	18.8	19.7	21.6	23.9
MPXLRBD0300R010N240	3	0.1	3	24	2.9	2.8°	70	6	4	●	1	25.1	26.2	28.8	*
MPXLRBD0300R010N300	3	0.1	3	30	2.9	2.3°	70	6	4	●	1	31.3	32.7	35.9	*
MPXLRBD0300R010N360	3	0.1	3	36	2.9	2.0°	90	6	4	●	1	37.6	39.3	*	*
MPXLRBD0300R020N120	3	0.2	3	12	2.9	4.5°	60	6	4	●	1	12.6	13.1	14.4	15.9
MPXLRBD0300R020N180	3	0.2	3	18	2.9	3.4°	60	6	4	●	1	18.8	19.6	21.6	23.9
MPXLRBD0300R020N240	3	0.2	3	24	2.9	2.8°	70	6	4	●	1	25.1	26.2	28.7	*
MPXLRBD0300R020N300	3	0.2	3	30	2.9	2.3°	70	6	4	●	1	31.3	32.7	35.9	*
MPXLRBD0300R020N360	3	0.2	3	36	2.9	2.0°	90	6	4	●	1	37.6	39.3	43.1	*
MPXLRBD0300R030N120	3	0.3	3	12	2.9	4.5°	60	6	4	●	1	12.5	13.1	14.4	15.9
MPXLRBD0300R030N180	3	0.3	3	18	2.9	3.5°	60	6	4	●	1	18.8	19.6	21.5	23.9
MPXLRBD0300R030N240	3	0.3	3	24	2.9	2.8°	70	6	4	●	1	25.1	26.2	28.7	*
MPXLRBD0300R030N300	3	0.3	3	30	2.9	2.3°	70	6	4	●	1	31.3	32.7	35.9	*
MPXLRBD0300R030N360	3	0.3	3	36	2.9	2.0°	90	6	4	●	1	37.6	39.2	*	*
MPXLRBD0300R050N120	3	0.5	3	12	2.9	4.6°	60	6	4	●	1	12.5	13.1	14.3	15.8
MPXLRBD0300R050N180	3	0.5	3	18	2.9	3.5°	60	6	4	●	1	18.8	19.6	21.5	23.8
MPXLRBD0300R050N240	3	0.5	3	24	2.9	2.8°	70	6	4	●	1	25.1	26.2	28.7	*
MPXLRBD0300R050N300	3	0.5	3	30	2.9	2.3°	70	6	4	●	1	31.3	32.7	35.9	*
MPXLRBD0300R050N360	3	0.5	3	36	2.9	2.0°	90	6	4	●	1	37.6	39.2	*	*
MPXLRBD0400R010N160	4	0.1	4	16	3.9	2.8°	70	6	4	●	1	16.7	17.5	19.2	*
MPXLRBD0400R010N240	4	0.1	4	24	3.9	2.0°	70	6	4	●	1	25.1	26.2	*	*
MPXLRBD0400R010N320	4	0.1	4	32	3.9	1.6°	70	6	4	●	1	33.4	34.9	*	*
MPXLRBD0400R010N480	4	0.1	4	48	3.9	1.1°	90	6	4	●	1	50.1	52.3	*	*
MPXLRBD0400R020N160	4	0.2	4	16	3.9	2.8°	70	6	4	●	1	16.7	17.5	19.2	*
MPXLRBD0400R020N240	4	0.2	4	24	3.9	2.0°	70	6	4	●	1	25.1	26.2	*	*
MPXLRBD0400R020N320	4	0.2	4	32	3.9	1.6°	70	6	4	●	1	33.4	34.9	*	*
MPXLRBD0400R020N480	4	0.2	4	48	3.9	1.1°	90	6	4	●	1	50.1	52.3	*	*
MPXLRBD0400R030N160	4	0.3	4	16	3.9	2.8°	70	6	4	●	1	16.7	17.5	19.1	*

* No interference

SOLID END MILLS

SQUARE

BALL

RADIUS

TAPER

BARREL

ROUGHING

MS PLUS END MILLS

MPXLRB

Corner radius, Short cut length, Long Neck, 2-4 flute

(mm)

Order Number	DC	RE	APMX	LU	DN	B2	LF	DCON	Flutes	Stock	Type	Effective length for inclined angle			
												0.5°	1°	2°	3°
MPXLRBD0400R030N240	4	0.3	4	24	3.9	2.0°	70	6	4	●	1	25.1	26.2	*	*
MPXLRBD0400R030N320	4	0.3	4	32	3.9	1.6°	70	6	4	●	1	33.4	34.9	*	*
MPXLRBD0400R030N480	4	0.3	4	48	3.9	1.1°	90	6	4	●	1	50.1	52.3	*	*
MPXLRBD0400R050N160	4	0.5	4	16	3.9	2.8°	70	6	4	●	1	16.7	17.4	19.1	*
MPXLRBD0400R050N240	4	0.5	4	24	3.9	2.0°	70	6	4	●	1	25.1	26.2	*	*
MPXLRBD0400R050N320	4	0.5	4	32	3.9	1.6°	70	6	4	●	1	33.4	34.9	*	*
MPXLRBD0400R050N480	4	0.5	4	48	3.9	1.1°	90	6	4	●	1	50.1	52.3	*	*
MPXLRBD0600R010N240	6	0.1	6	24	5.85	—	70	6	4	●	2	*	*	*	*
MPXLRBD0600R010N480	6	0.1	6	48	5.85	—	100	6	4	●	2	*	*	*	*
MPXLRBD0600R020N240	6	0.2	6	24	5.85	—	70	6	4	●	2	*	*	*	*
MPXLRBD0600R020N480	6	0.2	6	48	5.85	—	100	6	4	●	2	*	*	*	*
MPXLRBD0600R030N240	6	0.3	6	24	5.85	—	70	6	4	●	2	*	*	*	*
MPXLRBD0600R030N480	6	0.3	6	48	5.85	—	100	6	4	●	2	*	*	*	*
MPXLRBD0600R050N240	6	0.5	6	24	5.85	—	70	6	4	●	2	*	*	*	*
MPXLRBD0600R050N480	6	0.5	6	48	5.85	—	100	6	4	●	2	*	*	*	*

* No interference

CARBIDE

—

SOLID END MILLS

SQUARE

BALL

RADIUS

TAPER

BARREL

ROUGHING

● : Inventory maintained.

RECOMMENDED CUTTING CONDITIONS

■ Side milling

Work material		P				H			
		Carbon steel, Alloy steel (180—280HB), Pre-hardened steel, Precipitation hardening stainless steel (<450HB)				Hardened Steel (45—52HRC)			
Dia. DC (mm)	Neck length LU (mm)	Revolution (min ⁻¹)	Feed rate (mm/min)	Depth of cut ap (mm)	Depth of cut ae (mm)	Revolution (min ⁻¹)	Feed rate (mm/min)	Depth of cut ap (mm)	Depth of cut ae (mm)
0.2	0.5	30000	180	0.003	0.04	30000	150	0.003	0.04
	1	30000	120	0.003	0.04	30000	100	0.003	0.04
0.3	1	30000	210	0.003	0.08	30000	180	0.003	0.08
	2	30000	120	0.003	0.08	30000	100	0.003	0.08
0.4	2	31000	970	0.005	0.10	31000	810	0.005	0.10
	3	31000	790	0.004	0.10	31000	660	0.004	0.10
	4	31000	540	0.003	0.10	31000	450	0.003	0.10
0.5	2	31000	1500	0.006	0.12	31000	1300	0.006	0.12
	3	31000	1300	0.005	0.12	31000	1100	0.005	0.12
	4	31000	970	0.004	0.12	31000	810	0.004	0.12
	5	25000	790	0.004	0.12	25000	660	0.004	0.12
0.6	2	31000	2100	0.020	0.13	31000	1800	0.020	0.13
	4	25000	1300	0.015	0.13	25000	1100	0.015	0.13
	6	20000	790	0.008	0.13	20000	660	0.008	0.13
0.8	4	25000	3200	0.025	0.20	25000	2700	0.025	0.20
	6	20000	2100	0.020	0.20	20000	1800	0.020	0.20
1	3	24000	2400	0.045	0.30	20000	2000	0.045	0.30
	4	24000	1900	0.040	0.30	20000	1600	0.040	0.30
	5	24000	1800	0.035	0.25	20000	1500	0.035	0.25
	6	20000	1400	0.030	0.25	17000	1200	0.030	0.25
	8	20000	1000	0.020	0.20	17000	880	0.020	0.20
	10	15000	800	0.015	0.10	13000	670	0.015	0.10
	12	15000	370	0.010	0.01	13000	310	0.010	0.01
1.2	10	18000	1500	0.030	0.25	15000	1300	0.030	0.25
1.5	6	20000	2400	0.050	0.40	17000	2000	0.050	0.40
	12	15000	1400	0.040	0.30	13000	1200	0.040	0.30
	18	12000	670	0.010	0.15	10000	560	0.010	0.15
2	8	15000	2600	0.050	0.50	13000	2200	0.050	0.50
	12	15000	2100	0.045	0.50	13000	1800	0.045	0.50
	16	14000	1900	0.040	0.35	12000	1600	0.040	0.35
	20	14000	1100	0.015	0.25	12000	960	0.015	0.25
	24	9300	930	0.010	0.20	7800	780	0.010	0.20
3	8	12000	3300	0.100	0.80	10000	2800	0.100	0.80
	12	12000	3100	0.080	0.80	10000	2600	0.080	0.80
	18	11000	3100	0.070	0.70	9600	2600	0.070	0.70
	24	11000	2600	0.060	0.50	9300	2200	0.060	0.50
	30	9000	1300	0.030	0.40	7500	1100	0.030	0.40
	36	6200	910	0.010	0.30	5200	760	0.010	0.30
4	16	9000	3200	0.100	1.00	7500	2700	0.100	1.00
	24	7900	2500	0.085	0.80	6600	2100	0.085	0.80
	32	6900	1600	0.040	0.70	5800	1400	0.040	0.70
	48	4800	740	0.010	0.35	4000	620	0.010	0.35
6	24	5500	2700	0.120	1.50	4600	2263	0.120	1.50
	48	3800	1200	0.050	1.20	3200	1000	0.050	1.20

Depth of cut

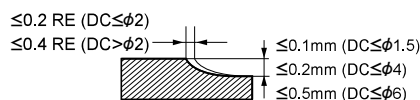

SOLID END MILLS

SQUARE

BALL

RADIUS

TAPER

BARREL

ROUGHING

MS PLUS END MILLS

MPXLRB

Corner radius, Short cut length, Long Neck, 2-4 flute

CARBIDE

SOLID END MILLS

SQUARE

BALL

RADIUS

TAPER

BARREL

ROUGHING

Work material		M				S				N			
		Austenitic stainless steels ($\leq 200\text{HB}$), Titanium alloys ($< 450\text{HB}$)				Copper, Copper alloys							
Dia. DC (mm)	Neck length LU (mm)	Revolution (min ⁻¹)	Feed rate (mm/min)	Depth of cut ap (mm)	Depth of cut ae (mm)	Revolution (min ⁻¹)	Feed rate (mm/min)	Depth of cut ap (mm)	Depth of cut ae (mm)				
0.2	0.5	33000	170	0.003	0.04	30000	150	0.003	0.08				
	1	30000	110	0.003	0.04	30000	100	0.003	0.08				
0.3	1	30000	200	0.003	0.08	30000	180	0.003	0.16				
	2	30000	110	0.003	0.08	30000	100	0.003	0.16				
0.4	2	31000	930	0.005	0.10	31000	810	0.005	0.20				
	3	31000	750	0.004	0.10	31000	660	0.004	0.20				
	4	31000	510	0.003	0.10	31000	450	0.003	0.20				
0.5	2	31000	1400	0.006	0.12	31000	1300	0.006	0.24				
	3	31000	1200	0.005	0.12	31000	1100	0.005	0.24				
	4	31000	930	0.004	0.12	31000	810	0.004	0.24				
	5	25000	750	0.004	0.12	25000	660	0.004	0.24				
0.6	2	31000	2000	0.020	0.13	31000	1800	0.020	0.26				
	4	25000	1200	0.015	0.13	25000	1100	0.015	0.26				
	6	20000	750	0.008	0.13	20000	660	0.008	0.26				
0.8	4	25000	3100	0.025	0.20	25000	2700	0.025	0.40				
	6	20000	2000	0.020	0.20	20000	1800	0.020	0.40				
1	3	23000	2300	0.045	0.30	20000	2000	0.045	0.60				
	4	23000	1800	0.040	0.30	20000	1600	0.040	0.60				
	5	23000	1700	0.035	0.25	20000	1500	0.035	0.50				
	6	19000	1300	0.030	0.25	17000	1200	0.030	0.50				
	8	19000	1000	0.020	0.20	17000	880	0.020	0.40				
	10	14000	770	0.015	0.10	13000	670	0.015	0.20				
1.2	10	14000	350	0.010	0.01	13000	310	0.010	0.02				
	10	17000	1400	0.030	0.25	15000	1300	0.030	0.50				
1.5	6	19000	2300	0.050	0.40	14700	1700	0.050	0.80				
	12	14000	1300	0.040	0.30	11000	1000	0.040	0.60				
	18	11000	640	0.010	0.15	8600	480	0.010	0.30				
2	8	14000	2500	0.050	0.50	11000	1900	0.050	1.00				
	12	14000	2000	0.045	0.50	11000	1500	0.045	1.00				
	16	13000	1800	0.040	0.35	10000	1300	0.040	0.70				
	20	13000	1100	0.015	0.25	10000	830	0.015	0.50				
	24	8900	890	0.010	0.20	6700	670	0.010	0.40				
3	8	11000	3200	0.100	0.80	8600	2400	0.100	1.60				
	12	11000	2900	0.080	0.80	8600	2200	0.080	1.60				
	18	11000	2900	0.070	0.70	8300	2200	0.070	1.40				
	24	10000	2500	0.060	0.50	8000	1900	0.060	1.00				
	30	8600	1200	0.030	0.40	6500	950	0.030	0.80				
	36	5900	870	0.010	0.30	4500	660	0.010	0.60				
4	16	8600	3100	0.100	1.00	6500	2300	0.100	2.00				
	24	7500	2400	0.085	0.80	5700	1800	0.085	1.60				
	32	6600	1600	0.040	0.70	5000	1200	0.040	1.40				
	48	4600	710	0.010	0.35	3400	530	0.010	0.70				
6	24	5200	2600	0.120	1.50	4000	1900	0.120	3.00				
	48	3600	1100	0.05	1.20	2700	870	0.050	2.40				

Depth of cut

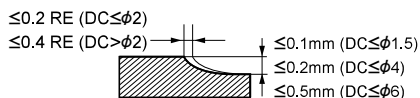

IMPACT MIRACLE END MILLS

VF4MB

Ball nose, Medium cut length, 4 flute



CARBIDE

Carbon Steel, Alloy Steel, Cast Iron (<30HRC)	Tool Steel, Pre-Hardened Steel, Hardened Steel (≤45HRC)	Hardened Steel (≤55HRC)	Hardened Steel (>55HRC)	Austenitic Stainless Steel	Titanium Alloy, Heat Resistant Alloy	Copper Alloy	Aluminium Alloy
	○	◎	◎				

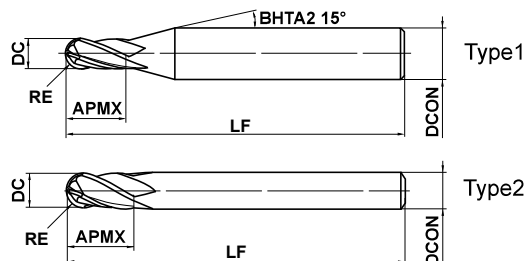

	0.5 ≤ RE ≤ 6				
	±0.01				
	1 ≤ DC ≤ 12				
	0 - 0.020				
	DCON=6	8 ≤ DCON ≤ 10	DCON=12		
	0 - 0.008	0 - 0.009	0 - 0.011		

● 4 flute ball nose end mill for high-speed machining of hardened steel.

(mm)

Order Number	RE	DC	APMX	LF	DCON	Flutes	Stock	Type
VF4MBR0050	0.5	1	2.5	50	6	4	●	1
VF4MBR0100	1	2	6	60	6	4	●	1
VF4MBR0150	1.5	3	8	70	6	4	●	1
VF4MBR0200	2	4	8	70	6	4	●	1
VF4MBR0250	2.5	5	12	80	6	4	●	1
VF4MBR0300	3	6	12	80	6	4	●	2
VF4MBR0400	4	8	14	90	8	4	●	2
VF4MBR0500	5	10	18	100	10	4	●	2
VF4MBR0600	6	12	22	110	12	4	●	2

SOLID END MILLS

SQUARE

BALL

RADIUS

TAPER

BARREL

ROUGHING

● : Inventory maintained.

IMPACT MIRACLE END MILLS

VF4MB

Ball nose, Medium cut length, 4 flute

CARBIDE

SOLID END MILLS

SQUARE

BALL

RADIUS

TAPER

BARREL

ROUGHING

RECOMMENDED CUTTING CONDITIONS

Work material	H														
	Hardened steel (45—55HRC)					Hardened steel (55—62HRC)					Hardened steel (62—70HRC)				
	X40CrMoV51					X210Cr12					070M55, 1.3343 (W6Mo5Cr4V2)				
RE (mm)	$\alpha \leq 15^\circ$		$\alpha > 15^\circ$		Depth of cut a_p (mm)	$\alpha \leq 15^\circ$		$\alpha > 15^\circ$		Depth of cut a_p (mm)	$\alpha \leq 15^\circ$		$\alpha > 15^\circ$		Depth of cut a_p (mm)
	Revolution (min ⁻¹)	Feed rate (mm/min)	Revolution (min ⁻¹)	Feed rate (mm/min)		Revolution (min ⁻¹)	Feed rate (mm/min)	Revolution (min ⁻¹)	Feed rate (mm/min)		Revolution (min ⁻¹)	Feed rate (mm/min)	Revolution (min ⁻¹)	Feed rate (mm/min)	
R0.5	40000	8000	40000	3800	0.06	40000	5600	40000	3100	0.05	40000	4700	32000	1700	0.03
R1	40000	9600	40000	5600	0.11	40000	8000	28000	3100	0.10	24000	5000	16000	1200	0.06
R1.5	40000	12000	32000	5600	0.13	32000	7700	19000	2900	0.12	16000	4200	11000	1100	0.07
R2	32000	11000	24000	4700	0.15	24000	6200	14000	2500	0.13	12000	3100	8000	1000	0.08
R2.5	25000	9000	19000	3800	0.20	19000	5300	12000	2200	0.15	9600	2700	6000	780	0.08
R3	21000	8400	15000	3400	0.25	16000	4800	9600	2000	0.20	8000	2300	5000	780	0.09
R4	16000	6400	12000	2600	0.30	12000	3600	7200	1600	0.20	6000	1900	4000	620	0.09
R5	13000	5200	9600	2200	0.50	10000	3200	5800	1300	0.20	4800	1500	3000	550	0.10
R6	9000	3600	7200	1700	0.50	7000	2200	4300	940	0.30	3600	1100	2200	400	0.10

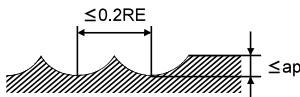

RE: Radius

Note 1) α is the inclination angle of the machined surface.

Note 2) If the depth of cut is shallow, the revolution and feed rate can be increased.

Note 3) If the rigidity of the machine or the work materials installation is very low, or chattering and noise are generated, reduce the revolution and feed rate proportionately.

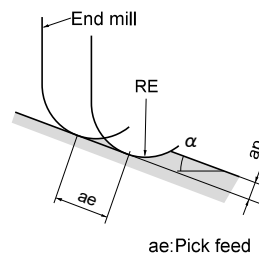

ae: Pick feed

VF2XLBS

Ball nose, Medium cut length, Short shank, 2 flute



CARBIDE

Carbon Steel, Alloy Steel, Cast Iron (<30HRC)	Tool Steel, Pre-Hardened Steel, Hardened Steel (≤45HRC)	Hardened Steel (≤55HRC)	Hardened Steel (>55HRC)	Austenitic Stainless Steel	Titanium Alloy, Heat Resistant Alloy	Copper Alloy	Aluminium Alloy
○	◎	◎	◎				

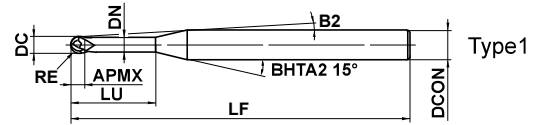

Effective length for inclined angle

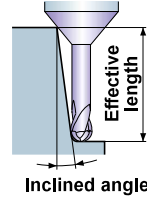

	0.2 ≤ RE ≤ 1				
	±0.007				
	0.4 ≤ DC ≤ 2				
	0 - 0.02				
	DCON=4				
	0 - 0.008				

- 2 flute long neck ball nose end mill for high-speed machining of hardened steel.
- Short shank type suitable for use with a shrink fit holder.

(mm)

Order Number	RE	DC	APMX	LU	DN	B2	LF	DCON	Flutes	Stock	Type	Effective length for inclined angle			
												0.5°	1°	2°	3°
VF2XLBSR0020N010	0.2	0.4	0.32	1	0.36	13.4°	40	4	2	★	1	1.0	1.0	1.1	1.2
VF2XLBSR0020N020	0.2	0.4	0.32	2	0.36	11.9°	40	4	2	★	1	2.0	2.1	2.3	2.5
VF2XLBSR0020N030	0.2	0.4	0.32	3	0.36	10.7°	40	4	2	★	1	3.1	3.2	3.4	3.7
VF2XLBSR0020N040	0.2	0.4	0.32	4	0.36	9.7°	40	4	2	★	1	4.1	4.3	4.6	4.9
VF2XLBSR0025N040	0.25	0.5	0.4	4	0.46	9.6°	40	4	2	★	1	4.1	4.3	4.6	4.9
VF2XLBSR0025N060	0.25	0.5	0.4	6	0.46	8.1°	40	4	2	★	1	6.2	6.4	6.9	7.4
VF2XLBSR0030N020	0.3	0.6	0.48	2	0.56	11.8°	40	4	2	★	1	2.1	2.2	2.3	2.5
VF2XLBSR0030N030	0.3	0.6	0.48	3	0.56	10.5°	40	4	2	★	1	3.1	3.3	3.5	3.8
VF2XLBSR0030N040	0.3	0.6	0.48	4	0.56	9.5°	40	4	2	★	1	4.2	4.3	4.6	5.0
VF2XLBSR0030N060	0.3	0.6	0.48	6	0.56	8.0°	40	4	2	★	1	6.3	6.5	6.9	7.5
VF2XLBSR0040N040	0.4	0.8	0.64	4	0.76	9.4°	40	4	2	★	1	4.2	4.3	4.6	5.0
VF2XLBSR0040N060	0.4	0.8	0.64	6	0.76	7.8°	40	4	2	★	1	6.3	6.5	6.9	7.5
VF2XLBSR0050N030	0.5	1	0.8	3	0.94	10.1°	40	4	2	★	1	3.2	3.3	3.6	3.9
VF2XLBSR0050N040	0.5	1	0.8	4	0.94	9.1°	40	4	2	★	1	4.2	4.4	4.8	5.2
VF2XLBSR0050N060	0.5	1	0.8	6	0.94	7.5°	40	4	2	★	1	6.3	6.6	7.1	7.7
VF2XLBSR0050N080	0.5	1	0.8	8	0.94	6.4°	40	4	2	★	1	8.4	8.8	9.4	10.2
VF2XLBSR0100N060	1	2	1.6	6	1.9	6.4°	40	4	2	★	1	6.2	6.5	6.9	7.4
VF2XLBSR0100N080	1	2	1.6	8	1.9	5.3°	40	4	2	★	1	8.3	8.7	9.2	9.9
VF2XLBSR0100N100	1	2	1.6	10	1.9	4.5°	40	4	2	★	1	10.4	10.8	11.5	12.4

SOLID END MILLS

SQUARE

BALL

RADIUS

TAPER

BARREL

ROUGHING

★ : Inventory maintained in Japan.

IMPACT MIRACLE END MILLS

VF2XLBS

Ball nose, Medium cut length, Short shank, 2 flute

CARBIDE

RECOMMENDED CUTTING CONDITIONS

Work material		H					
		Hardened steel (45—55HRC) X40CrMoV51			Hardened steel (55—62HRC) X210Cr12		
RE (mm)	Neck length LU (mm)	Revolution (min ⁻¹)	Feed rate (mm/min)	Depth of cut ap (mm)	Revolution (min ⁻¹)	Feed rate (mm/min)	Depth of cut ap (mm)
R 0.2	1	40000	1400	0.015	40000	1400	0.01
	2	40000	1000	0.01	40000	1000	0.006
	3	40000	700	0.005	40000	700	0.003
	4	40000	600	0.004	40000	500	0.003
R 0.25	4	36000	900	0.01	36000	900	0.007
	6	36000	600	0.006	36000	500	0.004
R 0.3	2	40000	2800	0.03	40000	2800	0.02
	3	40000	2800	0.03	40000	2800	0.02
	4	35000	2000	0.02	35000	2000	0.015
	6	35000	800	0.008	30000	800	0.005
R 0.4	4	40000	3000	0.02	40000	3000	0.015
	6	30000	1600	0.02	30000	1600	0.01
R 0.5	3	40000	4000	0.05	40000	4000	0.04
	4	40000	4000	0.05	40000	4000	0.04
	6	35000	2000	0.03	35000	2000	0.02
	8	35000	1600	0.02	30000	1600	0.01
R 1	6	40000	6000	0.1	24000	3400	0.1
	8	40000	5000	0.1	24000	3000	0.1
	10	40000	5000	0.08	24000	3000	0.07
Depth of cut							

RE:Radius

Note 1) If the depth of cut is shallow, the revolution and feed rate can be increased.

Note 2) Cutting condition may be considerably different due to the overhang (milling depth), depth of cut and type of machine tool.

Please use the above table as a standard.

SOLID END MILLS

SQUARE

BALL

RADIUS

TAPER

BARREL

ROUGHING

VF2XLB

Ball nose, Long cut length, For hardened materials, 2 flute



CARBIDE

Carbon Steel, Alloy Steel, Cast Iron (<30HRC)	Tool Steel, Pre-Hardened Steel, Hardened Steel (≤45HRC)	Hardened Steel (≤55HRC)	Hardened Steel (>55HRC)	Austenitic Stainless Steel	Titanium Alloy, Heat Resistant Alloy	Copper Alloy	Aluminium Alloy
---	---	-------------------------	-------------------------	----------------------------	--------------------------------------	--------------	-----------------

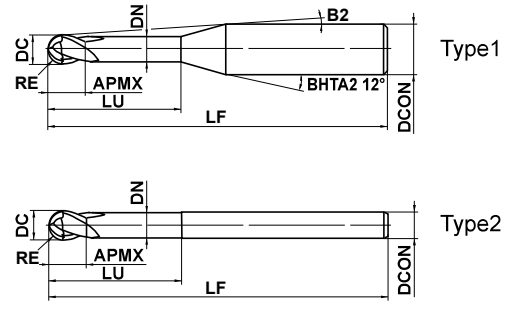

Effective length for inclined angle

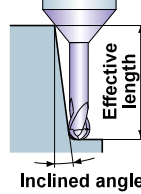

	RE ≤ 1	RE > 1			
	±0.007	±0.010			
	0.2 ≤ DC ≤ 6				
	⁰ - 0.02				
	4 ≤ DCON ≤ 6				
	⁰ - 0.008				

● 2 flute long neck ball nose end mill with Impact Miracle coating for high hardened materials.

(mm)

Order Number	RE	DC	APMX	LU	DN	B2	LF	DCON	Flutes	Stock	Type	Effective length for inclined angle			
												0.5°	1°	2°	3°
VF2XLB0010N005S04	0.1	0.2	0.16	0.5	0.17	11.5°	50	4	2	●	1	0.5	0.5	0.6	0.6
VF2XLB0010N005S06	0.1	0.2	0.16	0.5	0.17	11.7°	50	6	2	●	1	0.5	0.5	0.6	0.6
VF2XLB0010N008S04	0.1	0.2	0.16	0.75	0.17	11.2°	50	4	2	●	1	0.7	0.8	0.9	1.0
VF2XLB0010N010S04	0.1	0.2	0.16	1	0.17	10.9°	50	4	2	●	1	1.0	1.1	1.2	1.3
VF2XLB0010N010S06	0.1	0.2	0.16	1	0.17	11.3°	50	6	2	●	1	1.0	1.1	1.2	1.3
VF2XLB0010N013S04	0.1	0.2	0.16	1.25	0.17	10.7°	50	4	2	●	1	1.3	1.3	1.5	1.6
VF2XLB0010N015S04	0.1	0.2	0.16	1.5	0.17	10.4°	50	4	2	●	1	1.5	1.6	1.8	2.0
VF2XLB0010N015S06	0.1	0.2	0.16	1.5	0.17	10.9°	50	6	2	●	1	1.5	1.6	1.8	2.0
VF2XLB0010N018S04	0.1	0.2	0.16	1.75	0.17	10.2°	50	4	2	●	1	1.8	1.9	2.1	2.3
VF2XLB0010N020S04	0.1	0.2	0.16	2	0.17	10°	50	4	2	●	1	2.1	2.2	2.4	2.6
VF2XLB0010N025S04	0.1	0.2	0.16	2.5	0.17	9.5°	50	4	2	●	1	2.6	2.7	3.0	3.3
VF2XLB0015N010S04	0.15	0.3	0.24	1	0.27	11°	50	4	2	●	1	1.0	1.1	1.2	1.3
VF2XLB0015N010S06	0.15	0.3	0.24	1	0.27	11.3°	50	6	2	●	1	1.0	1.1	1.2	1.3
VF2XLB0015N013S04	0.15	0.3	0.24	1.25	0.27	10.7°	50	4	2	●	1	1.3	1.3	1.5	1.6
VF2XLB0015N015S04	0.15	0.3	0.24	1.5	0.27	10.4°	50	4	2	●	1	1.5	1.6	1.8	1.9
VF2XLB0015N015S06	0.15	0.3	0.24	1.5	0.27	10.9°	50	6	2	●	1	1.5	1.6	1.8	1.9
VF2XLB0015N018S04	0.15	0.3	0.24	1.75	0.27	10.2°	50	4	2	●	1	1.8	1.9	2.1	2.3
VF2XLB0015N020S04	0.15	0.3	0.24	2	0.27	9.9°	50	4	2	●	1	2.1	2.2	2.4	2.6
VF2XLB0015N020S06	0.15	0.3	0.24	2	0.27	10.6°	50	6	2	●	1	2.1	2.2	2.4	2.6
VF2XLB0015N025S04	0.15	0.3	0.24	2.5	0.27	9.5°	50	4	2	●	1	2.6	2.7	3.0	3.3
VF2XLB0015N030S04	0.15	0.3	0.24	3	0.27	9.1°	50	4	2	●	1	3.1	3.2	3.6	3.9
VF2XLB0015N040S04	0.15	0.3	0.24	4	0.27	8.4°	50	4	2	●	1	4.2	4.3	4.8	5.3
VF2XLB0020N010S04	0.2	0.4	0.32	1	0.36	11°	50	4	2	●	1	1.0	1.0	1.1	1.2
VF2XLB0020N010S06	0.2	0.4	0.32	1	0.36	11.3°	50	6	2	●	1	1.0	1.0	1.1	1.2
VF2XLB0020N015S04	0.2	0.4	0.32	1.5	0.36	10.4°	50	4	2	●	1	1.5	1.6	1.7	1.9
VF2XLB0020N015S06	0.2	0.4	0.32	1.5	0.36	11°	50	6	2	●	1	1.5	1.6	1.7	1.9
VF2XLB0020N020S04	0.2	0.4	0.32	2	0.36	10°	50	4	2	●	1	2.0	2.1	2.3	2.6
VF2XLB0020N020S06	0.2	0.4	0.32	2	0.36	10.6°	50	6	2	●	1	2.0	2.1	2.3	2.6
VF2XLB0020N025S04	0.2	0.4	0.32	2.5	0.36	9.5°	50	4	2	●	1	2.6	2.7	2.9	3.2
VF2XLB0020N025S06	0.2	0.4	0.32	2.5	0.36	10.3°	50	6	2	●	1	2.6	2.7	2.9	3.2
VF2XLB0020N030S04	0.2	0.4	0.32	3	0.36	9.1°	50	4	2	●	1	3.1	3.2	3.5	3.9
VF2XLB0020N030S06	0.2	0.4	0.32	3	0.36	10°	50	6	2	●	1	3.1	3.2	3.5	3.9
VF2XLB0020N040S04	0.2	0.4	0.32	4	0.36	8.4°	50	4	2	●	1	4.1	4.3	4.7	5.2
VF2XLB0020N050S04	0.2	0.4	0.32	5	0.36	7.8°	50	4	2	●	1	5.2	5.4	5.9	6.6

SOLID END MILLS

SQUARE

BALL

RADIUS

TAPER

BARREL

ROUGHING

● : Inventory maintained.

IMPACT MIRACLE END MILLS

VF2XLB

Ball nose, Long cut length, For hardened materials, 2 flute

(mm)

Order Number	RE	DC	APMX	LU	DN	B2	LF	DCON	Flutes	Stock	Type	Effective length for inclined angle			
												0.5°	1°	2°	3°
VF2XLBR0025N015S04	0.25	0.5	0.4	1.5	0.46	10.5°	50	4	2	●	1	1.5	1.6	1.7	1.9
VF2XLBR0025N015S06	0.25	0.5	0.4	1.5	0.46	11°	50	6	2	●	1	1.5	1.6	1.7	1.9
VF2XLBR0025N020S04	0.25	0.5	0.4	2	0.46	10°	50	4	2	●	1	2.0	2.1	2.3	2.6
VF2XLBR0025N020S06	0.25	0.5	0.4	2	0.46	10.6°	50	6	2	●	1	2.0	2.1	2.3	2.6
VF2XLBR0025N025S04	0.25	0.5	0.4	2.5	0.46	9.5°	50	4	2	●	1	2.6	2.7	2.9	3.2
VF2XLBR0025N030S04	0.25	0.5	0.4	3	0.46	9.1°	50	4	2	●	1	3.1	3.2	3.5	3.9
VF2XLBR0025N030S06	0.25	0.5	0.4	3	0.46	10°	50	6	2	●	1	3.1	3.2	3.5	3.9
VF2XLBR0025N035S04	0.25	0.5	0.4	3.5	0.46	8.7°	50	4	2	●	1	3.6	3.8	4.1	4.5
VF2XLBR0025N040S04	0.25	0.5	0.4	4	0.46	8.3°	50	4	2	●	1	4.1	4.3	4.7	5.2
VF2XLBR0025N040S06	0.25	0.5	0.4	4	0.46	9.4°	50	6	2	●	1	4.1	4.3	4.7	5.2
VF2XLBR0025N050S04	0.25	0.5	0.4	5	0.46	7.7°	50	4	2	●	1	5.2	5.4	5.9	6.5
VF2XLBR0025N050S06	0.25	0.5	0.4	5	0.46	8.9°	50	6	2	●	1	5.2	5.4	5.9	6.5
VF2XLBR0025N060S04	0.25	0.5	0.4	6	0.46	7.2°	50	4	2	●	1	6.2	6.5	7.1	7.9
VF2XLBR0025N060S06	0.25	0.5	0.4	6	0.46	8.4°	60	6	2	●	1	6.2	6.5	7.1	7.9
VF2XLBR0030N020S04	0.3	0.6	0.48	2	0.56	9.9°	50	4	2	●	1	2.1	2.2	2.4	2.6
VF2XLBR0030N020S06	0.3	0.6	0.48	2	0.56	10.6°	50	6	2	●	1	2.1	2.2	2.4	2.6
VF2XLBR0030N025S04	0.3	0.6	0.48	2.5	0.56	9.4°	50	4	2	●	1	2.6	2.7	3.0	3.3
VF2XLBR0030N030S04	0.3	0.6	0.48	3	0.56	9°	50	4	2	●	1	3.1	3.3	3.6	3.9
VF2XLBR0030N030S06	0.3	0.6	0.48	3	0.56	9.9°	50	6	2	●	1	3.1	3.3	3.6	3.9
VF2XLBR0030N035S04	0.3	0.6	0.48	3.5	0.56	8.6°	50	4	2	●	1	3.6	3.8	4.2	4.6
VF2XLBR0030N040S04	0.3	0.6	0.48	4	0.56	8.3°	50	4	2	●	1	4.2	4.4	4.8	5.2
VF2XLBR0030N040S06	0.3	0.6	0.48	4	0.56	9.3°	50	6	2	●	1	4.2	4.4	4.8	5.2
VF2XLBR0030N050S04	0.3	0.6	0.48	5	0.56	7.6°	50	4	2	●	1	5.2	5.4	6.0	6.6
VF2XLBR0030N050S06	0.3	0.6	0.48	5	0.56	8.8°	50	6	2	●	1	5.2	5.4	6.0	6.6
VF2XLBR0030N060S04	0.3	0.6	0.48	6	0.56	7.1°	50	4	2	●	1	6.3	6.5	7.1	7.9
VF2XLBR0030N060S06	0.3	0.6	0.48	6	0.56	8.4°	50	6	2	●	1	6.3	6.5	7.1	7.9
VF2XLBR0030N070S04	0.3	0.6	0.48	7	0.56	6.6°	50	4	2	●	1	7.3	7.6	8.3	9.2
VF2XLBR0030N080S04	0.3	0.6	0.48	8	0.56	6.2°	50	4	2	●	1	8.3	8.7	9.5	10.6
VF2XLBR0030N080S06	0.3	0.6	0.48	8	0.56	7.6°	60	6	2	●	1	8.3	8.7	9.5	10.6
VF2XLBR0040N020S04	0.4	0.8	0.64	2	0.76	9.9°	50	4	2	●	1	2.1	2.2	2.3	2.6
VF2XLBR0040N020S06	0.4	0.8	0.64	2	0.76	10.6°	50	6	2	●	1	2.1	2.2	2.3	2.6
VF2XLBR0040N030S04	0.4	0.8	0.64	3	0.76	8.9°	50	4	2	●	1	3.1	3.3	3.5	3.9
VF2XLBR0040N030S06	0.4	0.8	0.64	3	0.76	9.9°	50	6	2	●	1	3.1	3.3	3.5	3.9
VF2XLBR0040N040S04	0.4	0.8	0.64	4	0.76	8.2°	50	4	2	●	1	4.2	4.3	4.7	5.2
VF2XLBR0040N040S06	0.4	0.8	0.64	4	0.76	9.3°	50	6	2	●	1	4.2	4.3	4.7	5.2
VF2XLBR0040N050S04	0.4	0.8	0.64	5	0.76	7.5°	50	4	2	●	1	5.2	5.4	5.9	6.5
VF2XLBR0040N060S04	0.4	0.8	0.64	6	0.76	7°	50	4	2	●	1	6.3	6.5	7.1	7.9
VF2XLBR0040N060S06	0.4	0.8	0.64	6	0.76	8.3°	50	6	2	●	1	6.3	6.5	7.1	7.9
VF2XLBR0040N070S04	0.4	0.8	0.64	7	0.76	6.5°	50	4	2	●	1	7.3	7.6	8.3	9.2
VF2XLBR0040N080S04	0.4	0.8	0.64	8	0.76	6.1°	50	4	2	●	1	8.3	8.7	9.5	10.5
VF2XLBR0040N080S06	0.4	0.8	0.64	8	0.76	7.5°	50	6	2	●	1	8.3	8.7	9.5	10.5
VF2XLBR0040N100S04	0.4	0.8	0.64	10	0.76	5.4°	50	4	2	●	1	10.4	10.9	11.9	13.2
VF2XLBR0040N100S06	0.4	0.8	0.64	10	0.76	6.8°	60	6	2	●	1	10.4	10.9	11.9	13.2
VF2XLBR0050N030S04	0.5	1	0.8	3	0.94	8.8°	50	4	2	●	1	3.2	3.3	3.6	4.0
VF2XLBR0050N030S06	0.5	1	0.8	3	0.94	9.8°	50	6	2	●	1	3.2	3.3	3.6	4.0
VF2XLBR0050N040S04	0.5	1	0.8	4	0.94	8°	50	4	2	●	1	4.2	4.4	4.8	5.3
VF2XLBR0050N040S06	0.5	1	0.8	4	0.94	9.2°	50	6	2	●	1	4.2	4.4	4.8	5.3
VF2XLBR0050N050S04	0.5	1	0.8	5	0.94	7.3°	50	4	2	●	1	5.3	5.5	6.0	6.7
VF2XLBR0050N050S06	0.5	1	0.8	5	0.94	8.7°	50	6	2	●	1	5.3	5.5	6.0	6.7
VF2XLBR0050N060S04	0.5	1	0.8	6	0.94	6.8°	50	4	2	●	1	6.3	6.6	7.2	8.0
VF2XLBR0050N060S06	0.5	1	0.8	6	0.94	8.2°	50	6	2	●	1	6.3	6.6	7.2	8.0
VF2XLBR0050N070S04	0.5	1	0.8	7	0.94	6.3°	50	4	2	●	1	7.4	7.7	8.4	9.3

● : Inventory maintained.

(mm)

Order Number	RE	DC	APMX	LU	DN	B2	LF	DCON	Flutes	Stock	Type	Effective length for inclined angle			
												0.5°	1°	2°	3°
VF2XLBR0050N080S04	0.5	1	0.8	8	0.94	5.9°	50	4	2	●	1	8.4	8.8	9.6	10.6
VF2XLBR0050N080S06	0.5	1	0.8	8	0.94	7.4°	50	6	2	●	1	8.4	8.8	9.6	10.6
VF2XLBR0050N090S04	0.5	1	0.8	9	0.94	5.5°	50	4	2	●	1	9.5	9.9	10.8	12.0
VF2XLBR0050N100S04	0.5	1	0.8	10	0.94	5.2°	50	4	2	●	1	10.5	11.0	12.0	13.3
VF2XLBR0050N100S06	0.5	1	0.8	10	0.94	6.7°	50	6	2	●	1	10.5	11.0	12.0	13.3
VF2XLBR0050N120S04	0.5	1	0.8	12	0.94	4.6°	50	4	2	●	1	12.6	13.2	14.4	15.9
VF2XLBR0050N120S06	0.5	1	0.8	12	0.94	6.1°	60	6	2	●	1	12.6	13.2	14.4	15.9
VF2XLBR0050N140S04	0.5	1	0.8	14	0.94	4.2°	60	4	2	●	1	14.7	15.3	16.8	18.6
VF2XLBR0050N160S04	0.5	1	0.8	16	0.94	3.8°	60	4	2	●	1	16.8	17.5	19.2	21.3
VF2XLBR0050N160S06	0.5	1	0.8	16	0.94	5.3°	70	6	2	●	1	16.8	17.5	19.2	21.3
VF2XLBR0050N180S04	0.5	1	0.8	18	0.94	3.5°	60	4	2	●	1	18.9	19.7	21.6	23.9
VF2XLBR0050N200S04	0.5	1	0.8	20	0.94	3.3°	60	4	2	●	1	21.0	21.9	24.0	26.6
VF2XLBR0050N200S06	0.5	1	0.8	20	0.94	4.6°	70	6	2	●	1	21.0	21.9	24.0	26.6
VF2XLBR0060N060S04	0.6	1.2	0.96	6	1.14	6.6°	50	4	2	●	1	6.3	6.6	7.2	8.0
VF2XLBR0060N060S06	0.6	1.2	0.96	6	1.14	8.1°	50	6	2	●	1	6.3	6.6	7.2	8.0
VF2XLBR0060N080S04	0.6	1.2	0.96	8	1.14	5.7°	50	4	2	●	1	8.4	8.8	9.6	10.6
VF2XLBR0060N080S06	0.6	1.2	0.96	8	1.14	7.3°	50	6	2	●	1	8.4	8.8	9.6	10.6
VF2XLBR0060N100S04	0.6	1.2	0.96	10	1.14	5°	50	4	2	●	1	10.5	11.0	12.0	13.3
VF2XLBR0060N100S06	0.6	1.2	0.96	10	1.14	6.6°	50	6	2	●	1	10.5	11.0	12.0	13.3
VF2XLBR0060N120S04	0.6	1.2	0.96	12	1.14	4.5°	50	4	2	●	1	12.6	13.2	14.4	15.9
VF2XLBR0060N120S06	0.6	1.2	0.96	12	1.14	6°	50	6	2	●	1	12.6	13.2	14.4	15.9
VF2XLBR0060N140S04	0.6	1.2	0.96	14	1.14	4°	60	4	2	●	1	14.7	15.3	16.8	18.6
VF2XLBR0060N160S04	0.6	1.2	0.96	16	1.14	3.7°	60	4	2	●	1	16.8	17.5	19.2	21.2
VF2XLBR0060N160S06	0.6	1.2	0.96	16	1.14	5.2°	70	6	2	●	1	16.8	17.5	19.2	21.2
VF2XLBR0070N080S04	0.7	1.4	1.12	8	1.34	5.5°	50	4	2	●	1	8.4	8.8	9.6	10.6
VF2XLBR0070N120S04	0.7	1.4	1.12	12	1.34	4.3°	50	4	2	●	1	12.6	13.1	14.4	15.9
VF2XLBR0070N160S04	0.7	1.4	1.12	16	1.34	3.5°	60	4	2	●	1	16.8	17.5	19.2	21.2
VF2XLBR0075N060S04	0.75	1.5	1.2	6	1.44	6.3°	50	4	2	●	1	6.3	6.6	7.2	7.9
VF2XLBR0075N060S06	0.75	1.5	1.2	6	1.44	8°	50	6	2	●	1	6.3	6.6	7.2	7.9
VF2XLBR0075N080S04	0.75	1.5	1.2	8	1.44	5.4°	50	4	2	●	1	8.4	8.8	9.6	10.6
VF2XLBR0075N080S06	0.75	1.5	1.2	8	1.44	7.2°	50	6	2	●	1	8.4	8.8	9.6	10.6
VF2XLBR0075N100S04	0.75	1.5	1.2	10	1.44	4.7°	50	4	2	●	1	10.5	11.0	12.0	13.2
VF2XLBR0075N100S06	0.75	1.5	1.2	10	1.44	6.5°	50	6	2	●	1	10.5	11.0	12.0	13.2
VF2XLBR0075N120S04	0.75	1.5	1.2	12	1.44	4.2°	50	4	2	●	1	12.6	13.1	14.4	15.9
VF2XLBR0075N120S06	0.75	1.5	1.2	12	1.44	5.9°	50	6	2	●	1	12.6	13.1	14.4	15.9
VF2XLBR0075N140S04	0.75	1.5	1.2	14	1.44	3.8°	50	4	2	●	1	14.7	15.3	16.8	18.5
VF2XLBR0075N140S06	0.75	1.5	1.2	14	1.44	5.4°	50	6	2	●	1	14.7	15.3	16.8	18.5
VF2XLBR0075N160S04	0.75	1.5	1.2	16	1.44	3.4°	60	4	2	●	1	16.8	17.5	19.2	21.2
VF2XLBR0075N160S06	0.75	1.5	1.2	16	1.44	5°	60	6	2	●	1	16.8	17.5	19.2	21.2
VF2XLBR0075N180S04	0.75	1.5	1.2	18	1.44	3.1°	60	4	2	●	1	18.9	19.7	21.6	23.8
VF2XLBR0075N200S04	0.75	1.5	1.2	20	1.44	2.9°	60	4	2	●	1	21.0	21.9	23.9	*
VF2XLBR0075N200S06	0.75	1.5	1.2	20	1.44	4.3°	70	6	2	●	1	21.0	21.9	23.9	26.5
VF2XLBR0080N080S04	0.8	1.6	1.28	8	1.54	5.3°	50	4	2	●	1	8.4	8.8	9.6	10.5
VF2XLBR0080N120S04	0.8	1.6	1.28	12	1.54	4.1°	50	4	2	●	1	12.6	13.1	14.4	15.9
VF2XLBR0080N160S04	0.8	1.6	1.28	16	1.54	3.3°	60	4	2	●	1	16.8	17.5	19.1	21.2
VF2XLBR0080N200S04	0.8	1.6	1.28	20	1.54	2.8°	60	4	2	●	1	21.0	21.9	23.9	*
VF2XLBR0090N080S04	0.9	1.8	1.44	8	1.74	5.1°	50	4	2	●	1	8.4	8.8	9.6	10.5
VF2XLBR0090N120S04	0.9	1.8	1.44	12	1.74	3.9°	50	4	2	●	1	12.6	13.1	14.3	15.8
VF2XLBR0090N160S04	0.9	1.8	1.44	16	1.74	3.1°	60	4	2	●	1	16.8	17.5	19.1	21.1
VF2XLBR0090N200S04	0.9	1.8	1.44	20	1.74	2.6°	60	4	2	●	1	20.9	21.8	23.9	*
VF2XLBR0100N060S04	1	2	1.6	6	1.9	5.8°	50	4	2	●	1	6.2	6.5	7.0	7.7
VF2XLBR0100N060S06	1	2	1.6	6	1.9	7.9°	50	6	2	●	1	6.2	6.5	7.0	7.7

* No interference

SOLID END MILLS

SQUARE

BALL

RADIUS

TAPER

BARREL

ROUGHING

IMPACT MIRACLE END MILLS

VF2XLB

Ball nose, Long cut length, For hardened materials, 2 flute

(mm)

Order Number	RE	DC	APMX	LU	DN	B2	LF	DCON	Flutes	Stock	Type	Effective length for inclined angle			
												0.5°	1°	2°	3°
VF2XLB0100N080S04	1	2	1.6	8	1.9	4.9°	50	4	2	●	1	8.3	8.7	9.4	10.4
VF2XLB0100N080S06	1	2	1.6	8	1.9	6.9°	50	6	2	●	1	8.3	8.7	9.4	10.4
VF2XLB0100N100S04	1	2	1.6	10	1.9	4.2°	50	4	2	●	1	10.4	10.9	11.8	13.0
VF2XLB0100N100S06	1	2	1.6	10	1.9	6.2°	50	6	2	●	1	10.4	10.9	11.8	13.0
VF2XLB0100N120S04	1	2	1.6	12	1.9	3.7°	50	4	2	●	1	12.5	13.0	14.2	15.7
VF2XLB0100N120S06	1	2	1.6	12	1.9	5.6°	50	6	2	●	1	12.5	13.0	14.2	15.7
VF2XLB0100N140S04	1	2	1.6	14	1.9	3.3°	50	4	2	●	1	14.6	15.2	16.6	18.3
VF2XLB0100N140S06	1	2	1.6	14	1.9	5.1°	50	6	2	●	1	14.6	15.2	16.6	18.3
VF2XLB0100N160S04	1	2	1.6	16	1.9	2.9°	60	4	2	●	1	16.7	17.4	19.0	*
VF2XLB0100N160S06	1	2	1.6	16	1.9	4.7°	60	6	2	●	1	16.7	17.4	19.0	21.0
VF2XLB0100N180S04	1	2	1.6	18	1.9	2.7°	60	4	2	●	1	18.8	19.6	21.4	*
VF2XLB0100N180S06	1	2	1.6	18	1.9	4.4°	60	6	2	●	1	18.8	19.6	21.4	23.6
VF2XLB0100N200S04	1	2	1.6	20	1.9	2.5°	60	4	2	●	1	20.9	21.8	23.8	*
VF2XLB0100N200S06	1	2	1.6	20	1.9	4.1°	60	6	2	●	1	20.9	21.8	23.8	26.3
VF2XLB0100N220S04	1	2	1.6	22	1.9	2.3°	60	4	2	●	1	22.9	23.9	26.2	*
VF2XLB0100N250S04	1	2	1.6	25	1.9	2°	70	4	2	●	1	26.1	27.2	*	*
VF2XLB0100N250S06	1	2	1.6	25	1.9	3.5°	70	6	2	●	1	26.1	27.2	29.8	32.9
VF2XLB0100N300S04	1	2	1.6	30	1.9	1.7°	70	4	2	●	1	31.3	32.6	*	*
VF2XLB0100N300S06	1	2	1.6	30	1.9	3°	80	6	2	●	1	31.3	32.6	35.8	*
VF2XLB0100N350S04	1	2	1.6	35	1.9	1.5°	80	4	2	●	1	36.5	38.1	*	*
VF2XLB0125N100S06	1.25	2.5	2	10	2.4	5.9°	60	6	2	●	1	10.4	10.8	11.8	12.9
VF2XLB0125N150S06	1.25	2.5	2	15	2.4	4.6°	60	6	2	●	1	15.6	16.3	17.8	19.6
VF2XLB0125N200S06	1.25	2.5	2	20	2.4	3.7°	70	6	2	●	1	20.8	21.7	23.8	26.2
VF2XLB0125N250S06	1.25	2.5	2	25	2.4	3.2°	70	6	2	●	1	26.1	27.2	29.7	32.9
VF2XLB0125N300S06	1.25	2.5	2	30	2.4	2.8°	80	6	2	●	1	31.3	32.6	35.7	*
VF2XLB0125N350S06	1.25	2.5	2	35	2.4	2.4°	80	6	2	●	1	36.5	38.1	41.7	*
VF2XLB0150N080S06	1.5	3	2.4	8	2.9	6.3°	60	6	2	●	1	8.3	8.6	9.3	10.2
VF2XLB0150N100S06	1.5	3	2.4	10	2.9	5.5°	60	6	2	●	1	10.4	10.8	11.7	12.9
VF2XLB0150N120S06	1.5	3	2.4	12	2.9	4.9°	60	6	2	●	1	12.5	13.0	14.1	15.5
VF2XLB0150N140S06	1.5	3	2.4	14	2.9	4.4°	60	6	2	●	1	14.6	15.2	16.5	18.2
VF2XLB0150N160S06	1.5	3	2.4	16	2.9	4°	60	6	2	●	1	16.7	17.3	18.9	20.8
VF2XLB0150N200S06	1.5	3	2.4	20	2.9	3.4°	70	6	2	●	1	20.8	21.7	23.7	26.1
VF2XLB0150N250S06	1.5	3	2.4	25	2.9	2.8°	70	6	2	●	1	26.1	27.2	29.7	*
VF2XLB0150N300S06	1.5	3	2.4	30	2.9	2.5°	70	6	2	●	1	31.3	32.6	35.7	*
VF2XLB0150N350S06	1.5	3	2.4	35	2.9	2.2°	80	6	2	●	1	36.5	38.0	41.7	*
VF2XLB0150N400S06	1.5	3	2.4	40	2.9	1.9°	90	6	2	●	1	41.7	43.5	*	*
VF2XLB0175N160S06	1.75	3.5	2.8	16	3.4	3.6°	60	6	2	●	1	16.7	17.3	18.9	20.8
VF2XLB0175N200S06	1.75	3.5	2.8	20	3.4	3°	70	6	2	●	1	20.8	21.7	23.7	*
VF2XLB0175N250S06	1.75	3.5	2.8	25	3.4	2.5°	70	6	2	●	1	26.0	27.1	29.6	*
VF2XLB0175N300S06	1.75	3.5	2.8	30	3.4	2.1°	80	6	2	●	1	31.3	32.6	35.6	*
VF2XLB0175N350S06	1.75	3.5	2.8	35	3.4	1.9°	80	6	2	●	1	36.5	38.0	*	*
VF2XLB0175N400S06	1.75	3.5	2.8	40	3.4	1.7°	90	6	2	●	1	41.7	43.5	*	*
VF2XLB0200N100S06	2	4	3.2	10	3.9	4.5°	70	6	2	●	1	10.4	10.8	11.6	12.7
VF2XLB0200N120S06	2	4	3.2	12	3.9	3.9°	70	6	2	●	1	12.5	12.9	14.0	15.4
VF2XLB0200N140S06	2	4	3.2	14	3.9	3.4°	70	6	2	●	1	14.6	15.1	16.4	18.0
VF2XLB0200N160S06	2	4	3.2	16	3.9	3.1°	70	6	2	●	1	16.6	17.3	18.8	20.7
VF2XLB0200N200S06	2	4	3.2	20	3.9	2.6°	70	6	2	●	1	20.8	21.7	23.6	*
VF2XLB0200N250S06	2	4	3.2	25	3.9	2.1°	70	6	2	●	1	26.0	27.1	29.6	*
VF2XLB0200N300S06	2	4	3.2	30	3.9	1.8°	70	6	2	●	1	31.2	32.6	*	*
VF2XLB0200N350S06	2	4	3.2	35	3.9	1.6°	80	6	2	●	1	36.5	38.0	*	*
VF2XLB0200N400S06	2	4	3.2	40	3.9	1.4°	90	6	2	●	1	41.7	43.5	*	*
VF2XLB0200N450S06	2	4	3.2	45	3.9	1.2°	90	6	2	●	1	46.9	48.9	*	*

* No interference

● : Inventory maintained.

(mm)

Order Number	RE	DC	APMX	LU	DN	B2	LF	DCON	Flutes	Stock	Type	Effective length for inclined angle			
												0.5°	1°	2°	3°
VF2XLBR0200N500S06	2	4	3.2	50	3.9	1.1°	100	6	2	●	1	52.1	54.3	*	*
VF2XLBR0250N200S06	2.5	5	4	20	4.9	1.5°	70	6	2	●	1	20.8	21.6	*	*
VF2XLBR0250N250S06	2.5	5	4	25	4.9	1.2°	70	6	2	●	1	26.0	27.1	*	*
VF2XLBR0250N300S06	2.5	5	4	30	4.9	1°	80	6	2	●	1	31.2	*	*	*
VF2XLBR0250N350S06	2.5	5	4	35	4.9	0.9°	80	6	2	●	1	36.4	*	*	*
VF2XLBR0300N300S06	3	6	4.8	30	5.85	—	80	6	2	●	2	*	*	*	*
VF2XLBR0300N400S06	3	6	4.8	40	5.85	—	90	6	2	●	2	*	*	*	*
VF2XLBR0300N500S06	3	6	4.8	50	5.85	—	100	6	2	●	2	*	*	*	*

* No interference

SOLID END MILLS

SQUARE

BALL

RADIUS

TAPER

BARREL

ROUGHING

IMPACT MIRACLE END MILLS

VF2XLB

Ball nose, Long cut length, For hardened materials, 2 flute

CARBIDE

RECOMMENDED CUTTING CONDITIONS

Work material		H					
		Hardened steel (45—55HRC)			Hardened steel (55—62HRC)		
		X40CrMoV51			X210Cr12		
RE (mm)	Neck length LU (mm)	Revolution (min ⁻¹)	Feed rate (mm/min)	Depth of cut ap (mm)	Revolution (min ⁻¹)	Feed rate (mm/min)	Depth of cut ap (mm)
R 0.1	0.5	40000	300	0.003	40000	300	0.002
	1	40000	300	0.002	40000	300	0.002
	1.5	40000	300	0.001	40000	200	0.001
	2	40000	200	0.001	40000	100	0.001
	2.5	40000	100	0.001	40000	60	0.001
R 0.15	1	40000	500	0.007	40000	500	0.005
	1.5	40000	500	0.005	40000	500	0.003
	2	40000	500	0.003	40000	500	0.002
	2.5	40000	400	0.003	40000	400	0.002
	3	40000	300	0.002	40000	300	0.001
R 0.2	4	30000	200	0.002	30000	200	0.001
	1	40000	1400	0.015	40000	1400	0.01
	1.5	40000	1000	0.01	40000	1000	0.006
	2	40000	1000	0.01	40000	1000	0.006
	2.5	40000	700	0.005	40000	700	0.003
R 0.25	3	40000	700	0.005	40000	700	0.003
	4	40000	600	0.004	40000	500	0.003
	5	40000	400	0.003	40000	300	0.002
	1.5	40000	2000	0.02	40000	2000	0.015
	2	40000	2000	0.02	40000	2000	0.015
	3	40000	1200	0.015	40000	1200	0.01
R 0.3	4	36000	900	0.01	36000	900	0.007
	5	36000	700	0.007	36000	600	0.005
	6	36000	600	0.006	36000	500	0.004
	2	40000	2800	0.03	40000	2800	0.02
	3	40000	2800	0.03	40000	2800	0.02
	4	35000	2000	0.02	35000	2000	0.015
	5	30000	1000	0.01	30000	1000	0.007
	6	30000	800	0.008	30000	800	0.005
R 0.4	7	30000	600	0.008	30000	600	0.005
	8	25000	400	0.006	25000	400	0.004
	2	40000	3500	0.04	40000	3500	0.03
	3	40000	3000	0.04	40000	3000	0.03
	4	40000	3000	0.02	40000	3000	0.015
	6	30000	1600	0.02	30000	1600	0.01
	8	25000	1000	0.01	25000	1000	0.007
R 0.5	10	25000	600	0.008	25000	600	0.005
	3	40000	4000	0.05	40000	4000	0.04
	4	40000	4000	0.05	40000	4000	0.04
	5	40000	3000	0.03	40000	3000	0.02
	6	35000	2000	0.03	35000	2000	0.02
	8	30000	1600	0.02	30000	1600	0.01
	10	20000	1000	0.01	20000	1000	0.01
	12	20000	1000	0.01	18000	800	0.008
	14	18000	600	0.008	18000	480	0.008
	16	18000	500	0.008	18000	400	0.006
R 0.6	18	13000	300	0.005	13000	240	0.004
	20	13000	250	0.005	13000	200	0.004
	6	40000	4000	0.05	35000	3500	0.04
	8	40000	3000	0.05	27000	2000	0.04
	10	27000	1900	0.03	24000	1700	0.02
	12	16000	1100	0.02	16000	1000	0.01
	14	16000	850	0.01	16000	780	0.01
R 0.7	16	15000	500	0.01	14000	400	0.006
	8	40000	4500	0.06	28000	3200	0.05
	12	32000	3000	0.03	19000	1800	0.02
	16	15000	1000	0.02	14000	800	0.01
	R 0.75	6	40000	5000	0.07	32000	4000
8		40000	5000	0.07	28000	3500	0.06
10		40000	4500	0.06	21000	2400	0.04
12		32000	3400	0.04	19000	2000	0.03
14		16000	1500	0.04	13000	1200	0.03
16		13000	1200	0.03	13000	1200	0.02

Work material		H					
		Hardened steel (45—55HRC)			Hardened steel (55—62HRC)		
		X40CrMoV51			X210Cr12		
RE (mm)	Neck length LU (mm)	Revolution (min ⁻¹)	Feed rate (mm/min)	Depth of cut ap (mm)	Revolution (min ⁻¹)	Feed rate (mm/min)	Depth of cut ap (mm)
R 0.75	18	13000	1100	0.02	10000	800	0.02
	20	12000	900	0.02	9000	700	0.01
	8	40000	5000	0.08	26000	3200	0.07
R 0.8	12	35000	3800	0.05	20000	2100	0.03
	16	13000	1200	0.04	12000	1100	0.02
	20	10000	750	0.02	8000	600	0.01
R 0.9	8	40000	5000	0.09	25000	3100	0.08
	12	36000	3800	0.06	18000	1900	0.04
	16	25000	2500	0.04	14000	1300	0.025
	20	10000	1000	0.03	8000	800	0.02
	R 1	6	40000	6000	0.1	24000	3400
8		40000	5000	0.1	24000	3000	0.1
10		40000	5000	0.08	24000	3000	0.07
12		40000	5000	0.08	24000	2600	0.05
14		40000	5000	0.06	21000	2300	0.05
16		32000	3500	0.05	16000	1700	0.03
18		24000	2400	0.04	13000	1300	0.03
20		10000	1000	0.04	10000	1000	0.03
22		10000	1000	0.04	10000	1000	0.02
25		10000	1000	0.04	8000	800	0.02
30		10000	800	0.02	8000	800	0.015
35		10000	500	0.02	8000	400	0.01
R 1.25		10	36000	5000	0.12	20000	2600
	15	36000	4600	0.08	18000	2000	0.075
	20	26000	3000	0.07	13000	1400	0.05
	25	10000	1100	0.06	8000	800	0.04
	30	8000	800	0.05	7000	700	0.03
	35	8000	500	0.03	5000	400	0.03
R 1.5	8	32000	6400	0.15	16000	3000	0.15
	10	32000	5100	0.15	16000	2200	0.15
	12	32000	5100	0.13	16000	2200	0.13
	14	32000	4500	0.13	16000	2200	0.1
	16	32000	4500	0.1	16000	1800	0.1
	20	27000	3800	0.1	14000	1600	0.06
	25	21000	2700	0.08	11000	1200	0.06
	30	9000	1000	0.08	7000	700	0.05
	35	6000	700	0.06	6000	600	0.04
	40	6000	600	0.04	5000	400	0.03
R 1.75	16	28000	4200	0.13	14000	1600	0.13
	20	26000	3800	0.13	13000	1600	0.11
	25	23000	3300	0.12	11000	1200	0.08
	30	13000	1900	0.09	9000	1000	0.07
	35	9000	1200	0.08	6000	600	0.06
	40	8500	1100	0.07	5500	500	0.04
R 2	10	24000	4800	0.2	12000	2200	0.2
	12	24000	4800	0.2	12000	2200	0.2
	14	24000	3800	0.15	12000	1500	0.15
	16	24000	3800	0.15	12000	1500	0.15
	20	24000	3800	0.15	12000	1500	0.15
	25	24000	3800	0.15	10000	1100	0.1
	30	20000	3000	0.1	10000	1100	0.08
	35	12000	1700	0.1	8000	900	0.08
	40	11000	1500	0.1	5000	500	0.06
	45	10000	1300	0.08	5000	500	0.05
R 2.5	50	8000	1000	0.05	4000	400	0.04
	20	19000	3400	0.2	10000	1400	0.2
	25	19000	3400	0.2	10000	1400	0.2
	30	19000	3200	0.15	8000	1000	0.15
	35	16000	2700	0.1	8000	900	0.1
R 3	30	16000	3500	0.2	8000	1000	0.2
	40	16000	3000	0.15	8000	800	0.15
	50	16000	2700	0.15	6000	500	0.15

Depth of cut

$$\leq 0.1RE \text{ (RE} \leq 1)$$

$$\leq 0.2RE \text{ (RE} > 1)$$

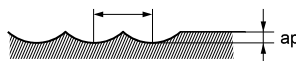

RE: Radius

Note 1) If the depth of cut is shallow, the revolution and feed rate can be increased.

Note 2) Cutting condition may be considerably different due to the overhang (milling depth), depth of cut and type of machine tool.

Please see the above table as a standard.

VF3XB

Ball nose, Taper neck, For hardened materials, 3 flute



CARBIDE

Carbon Steel, Alloy Steel, Cast Iron (<30HRC)	Tool Steel, Pre-Hardened Steel, Hardened Steel (<=45HRC)	Hardened Steel (<=55HRC)	Hardened Steel (>55HRC)	Austenitic Stainless Steel	Titanium Alloy, Heat Resistant Alloy	Copper Alloy	Aluminium Alloy
---	--	--------------------------	-------------------------	----------------------------	--------------------------------------	--------------	-----------------

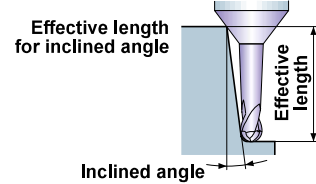
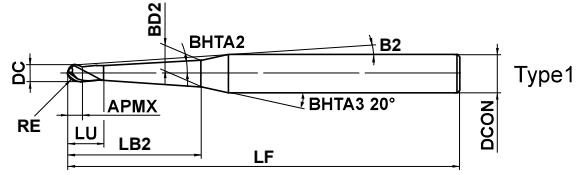

	0.4 ≤ RE ≤ 2.5				
	±0.01				
	0.8 ≤ DC ≤ 5				
	⁰ / _{-0.02}				
	4 ≤ DCON ≤ 6	DCON=8			
	⁰ / _{-0.008}	⁰ / _{-0.009}			

● 3 flute ball nose end mill, high rigidity taper neck type.

(mm)

Order Number	RE	DC	BHTA2	APMX	LB2	LU	B2	BD2	LF	DCON	Flutes	Stock	Type	Effective length for inclined angle			
														0.5°	1°	2°	3°
VF3XBR0040T0024L006	0.4	0.8	0.4°	0.5	6	1.5	8.9°	0.82	60	4	3	★	1	6.3	6.6	6.9	7.3
VF3XBR0040T0024L008	0.4	0.8	0.4°	0.5	8	1.5	7.5°	0.85	60	4	3	★	1	8.4	8.6	9.1	9.5
VF3XBR0040T0024L012	0.4	0.8	0.4°	0.5	12	1.5	5.7°	0.91	60	4	3	●	1	12.4	12.7	13.4	14.1
VF3XBR0040T0054L008	0.4	0.8	0.9°	0.5	8	1.5	7.6°	0.96	60	4	3	★	1	—	8.4	8.9	9.3
VF3XBR0040T0054L012	0.4	0.8	0.9°	0.5	12	1.5	5.8°	1.09	60	4	3	★	1	—	12.4	13.1	13.8
VF3XBR0040T0054L016	0.4	0.8	0.9°	0.5	16	1.5	4.7°	1.22	60	4	3	●	1	—	16.5	17.3	18.3
VF3XBR0050T0024L008	0.5	1	0.4°	0.8	8	2.3	9.6°	1.02	60	6	3	●	1	8.5	8.8	9.3	9.8
VF3XBR0050T0024L010	0.5	1	0.4°	0.8	10	2.3	8.5°	1.05	60	6	3	★	1	10.5	10.9	11.4	12.1
VF3XBR0050T0024L012	0.5	1	0.4°	0.8	12	2.3	7.6°	1.08	60	6	3	★	1	12.6	13.0	13.6	14.4
VF3XBR0050T0024L016	0.5	1	0.4°	0.8	16	2.3	6.3°	1.13	70	6	3	●	1	16.6	17.1	18.0	18.9
VF3XBR0050T0024L020	0.5	1	0.4°	0.8	20	2.3	5.4°	1.19	70	6	3	●	1	20.6	21.2	22.3	23.5
VF3XBR0050T0024L025	0.5	1	0.4°	0.8	25	2.3	4.6°	1.26	70	6	3	●	1	25.7	26.3	27.7	29.3
VF3XBR0050T0024L030	0.5	1	0.4°	0.8	30	2.3	4.0°	1.33	80	6	3	●	1	30.7	31.5	33.1	35.0
VF3XBR0050T0024L035	0.5	1	0.4°	0.8	35	2.3	3.5°	1.40	80	6	3	●	1	35.7	36.6	38.6	40.7
VF3XBR0050T0054L008	0.5	1	0.9°	0.8	8	2.3	9.7°	1.12	60	6	3	●	1	—	8.6	9.1	9.6
VF3XBR0050T0054L012	0.5	1	0.9°	0.8	12	2.3	7.7°	1.24	60	6	3	★	1	—	12.6	13.3	14.1
VF3XBR0050T0054L016	0.5	1	0.9°	0.8	16	2.3	6.4°	1.37	70	6	3	★	1	—	16.7	17.6	18.5
VF3XBR0050T0054L020	0.5	1	0.9°	0.8	20	2.3	5.5°	1.50	70	6	3	●	1	—	20.7	21.8	23.0
VF3XBR0050T0054L025	0.5	1	0.9°	0.8	25	2.3	4.7°	1.65	70	6	3	●	1	—	25.7	27.1	28.6
VF3XBR0050T0054L030	0.5	1	0.9°	0.8	30	2.3	4.0°	1.81	80	6	3	●	1	—	30.8	32.4	34.2
VF3XBR0050T0054L035	0.5	1	0.9°	0.8	35	2.3	3.6°	1.97	80	6	3	●	1	—	35.8	37.7	39.8
VF3XBR0050T0054L040	0.5	1	0.9°	0.8	40	2.3	3.2°	2.12	80	6	3	●	1	—	40.8	43.0	45.4
VF3XBR0050T0054L050	0.5	1	0.9°	0.8	50	2.3	2.7°	2.44	110	6	3	●	1	—	50.9	53.6	*
VF3XBR0050T0054L060	0.5	1	0.9°	0.8	60	2.3	2.3°	2.75	110	6	3	●	1	—	60.9	64.1	*
VF3XBR0050T0054L070	0.5	1	0.9°	0.8	70	2.3	2.0°	3.07	110	6	3	●	1	—	71.0	74.7	*
VF3XBR0050T0130L012	0.5	1	1.5°	0.8	12	2.3	7.9°	1.45	60	6	3	★	1	—	—	13.0	13.7
VF3XBR0050T0130L016	0.5	1	1.5°	0.8	16	2.3	6.5°	1.66	70	6	3	★	1	—	—	17.1	18.0
VF3XBR0050T0130L020	0.5	1	1.5°	0.8	20	2.3	5.6°	1.87	70	6	3	★	1	—	—	21.2	22.4
VF3XBR0050T0130L025	0.5	1	1.5°	0.8	25	2.3	4.8°	2.13	70	6	3	★	1	—	—	26.3	27.8
VF3XBR0050T0130L030	0.5	1	1.5°	0.8	30	2.3	4.1°	2.39	80	6	3	★	1	—	—	31.5	33.2
VF3XBR0050T0130L035	0.5	1	1.5°	0.8	35	2.3	3.7°	2.65	80	6	3	★	1	—	—	36.6	38.6
VF3XBR0075T0024L010	0.75	1.5	0.4°	1.3	10	2.8	8.1°	1.54	60	6	3	●	1	10.6	10.9	11.4	12.0
VF3XBR0075T0024L015	0.75	1.5	0.4°	1.3	15	2.8	6.2°	1.61	60	6	3	★	1	15.6	16.0	16.9	17.8
VF3XBR0075T0024L020	0.75	1.5	0.4°	1.3	20	2.8	5.0°	1.68	70	6	3	●	1	20.6	21.2	22.3	23.5

* No interference

● : Inventory maintained. ★ : Inventory maintained in Japan.

SOLID END MILLS

SQUARE

BALL

RADIUS

TAPER

BARREL

ROUGHING

IMPACT MIRACLE END MILLS

VF3XB

Ball nose, Taper neck, For hardened materials, 3 flute

(mm)

Order Number	RE	DC	BHTA2	APMX	LB2	LU	B2	BD2	LF	DCON	Flutes	Stock	Type	Effective length for inclined angle			
														0.5°	1°	2°	3°
VF3XBR0075T0024L030	0.75	1.5	0.4°	1.3	30	2.8	3.7°	1.82	80	6	3	●	1	30.7	31.5	33.1	35.0
VF3XBR0075T0054L015	0.75	1.5	0.9°	1.3	15	2.8	6.3°	1.82	60	6	3	★	1	—	15.7	16.5	17.4
VF3XBR0075T0054L020	0.75	1.5	0.9°	1.3	20	2.8	5.1°	1.98	70	6	3	●	1	—	20.7	21.8	23.0
VF3XBR0075T0054L030	0.75	1.5	0.9°	1.3	30	2.8	3.7°	2.29	80	6	3	●	1	—	30.8	32.4	34.2
VF3XBR0075T0054L040	0.75	1.5	0.9°	1.3	40	2.8	3.0°	2.61	80	6	3	●	1	—	40.8	43.0	45.3
VF3XBR0075T0130L015	0.75	1.5	1.5°	1.3	15	2.8	6.4°	2.08	60	6	3	●	1	—	—	16.1	17.0
VF3XBR0075T0130L020	0.75	1.5	1.5°	1.3	20	2.8	5.2°	2.34	70	6	3	★	1	—	—	21.2	22.4
VF3XBR0075T0130L030	0.75	1.5	1.5°	1.3	30	2.8	3.8°	2.86	80	6	3	★	1	—	—	31.5	33.2
VF3XBR0100T0024L016	1	2	0.4°	1.6	16	3.6	5.5°	2.07	70	6	3	●	1	16.7	17.1	18.0	19.0
VF3XBR0100T0024L020	1	2	0.4°	1.6	20	3.6	4.6°	2.13	70	6	3	★	1	20.7	21.3	22.3	23.5
VF3XBR0100T0024L025	1	2	0.4°	1.6	25	3.6	3.9°	2.20	70	6	3	★	1	25.8	26.4	27.8	29.3
VF3XBR0100T0024L030	1	2	0.4°	1.6	30	3.6	3.4°	2.27	80	6	3	●	1	30.8	31.6	33.2	35.0
VF3XBR0100T0024L035	1	2	0.4°	1.6	35	3.6	2.9°	2.34	80	6	3	★	1	35.8	36.7	38.6	*
VF3XBR0100T0024L040	1	2	0.4°	1.6	40	3.6	2.6°	2.41	80	6	3	●	1	40.8	41.9	44.0	*
VF3XBR0100T0054L020	1	2	0.9°	1.6	20	3.6	4.7°	2.42	70	6	3	●	1	—	20.8	21.9	23.0
VF3XBR0100T0054L025	1	2	0.9°	1.6	25	3.6	4.0°	2.57	70	6	3	●	1	—	25.8	27.2	28.6
VF3XBR0100T0054L030	1	2	0.9°	1.6	30	3.6	3.4°	2.73	80	6	3	●	1	—	30.9	32.5	34.2
VF3XBR0100T0054L035	1	2	0.9°	1.6	35	3.6	3.0°	2.89	80	6	3	★	1	—	35.9	37.7	39.8
VF3XBR0100T0054L040	1	2	0.9°	1.6	40	3.6	2.7°	3.04	80	6	3	●	1	—	40.9	43.0	*
VF3XBR0100T0054L050	1	2	0.9°	1.6	50	3.6	2.2°	3.36	110	6	3	●	1	—	51.0	53.6	*
VF3XBR0100T0054L060	1	2	0.9°	1.6	60	3.6	1.9°	3.67	110	6	3	●	1	—	61.0	*	*
VF3XBR0100T0054L070	1	2	0.9°	1.6	70	3.6	1.6°	3.99	110	6	3	●	1	—	71.1	*	*
VF3XBR0100T0130L025	1	2	1.5°	1.6	25	3.6	4.1°	3.02	70	6	3	●	1	—	—	26.4	27.9
VF3XBR0100T0130L030	1	2	1.5°	1.6	30	3.6	3.5°	3.28	80	6	3	★	1	—	—	31.6	33.3
VF3XBR0100T0130L035	1	2	1.5°	1.6	35	3.6	3.1°	3.54	80	6	3	★	1	—	—	36.7	38.7
VF3XBR0100T0130L040	1	2	1.5°	1.6	40	3.6	2.7°	3.81	80	6	3	●	1	—	—	41.8	*
VF3XBR0125T0054L020	1.25	2.5	0.9°	2	20	4.5	4.3°	2.89	60	6	3	★	1	—	20.8	21.9	23.1
VF3XBR0125T0054L030	1.25	2.5	0.9°	2	30	4.5	3.1°	3.20	80	6	3	★	1	—	30.9	32.5	34.2
VF3XBR0125T0054L040	1.25	2.5	0.9°	2	40	4.5	2.4°	3.52	80	6	3	●	1	—	40.9	43.1	*
VF3XBR0125T0130L020	1.25	2.5	1.5°	2	20	4.5	4.4°	3.21	60	6	3	★	1	—	—	21.4	22.5
VF3XBR0125T0130L030	1.25	2.5	1.5°	2	30	4.5	3.1°	3.74	80	6	3	★	1	—	—	31.6	33.3
VF3XBR0125T0130L040	1.25	2.5	1.5°	2	40	4.5	2.5°	4.26	80	6	3	●	1	—	—	41.9	*
VF3XBR0150T0024L020	1.5	3	0.4°	2	20	5	3.8°	3.11	60	6	3	●	1	20.7	21.3	22.3	23.5
VF3XBR0150T0024L025	1.5	3	0.4°	2	25	5	3.1°	3.18	80	6	3	★	1	25.8	26.4	27.7	29.2
VF3XBR0150T0024L030	1.5	3	0.4°	2	30	5	2.7°	3.25	80	6	3	●	1	30.8	31.6	33.2	*
VF3XBR0150T0024L040	1.5	3	0.4°	2	40	5	2.1°	3.39	80	6	3	●	1	40.9	41.9	44.0	*
VF3XBR0150T0024L050	1.5	3	0.4°	2	50	5	1.7°	3.53	100	6	3	●	1	50.9	52.2	*	*
VF3XBR0150T0054L020	1.5	3	0.9°	2	20	5	3.8°	3.37	60	6	3	★	1	—	20.9	21.9	23.0
VF3XBR0150T0054L030	1.5	3	0.9°	2	30	5	2.7°	3.69	80	6	3	●	1	—	30.9	32.5	*
VF3XBR0150T0054L040	1.5	3	0.9°	2	40	5	2.1°	4.00	80	6	3	●	1	—	41.0	43.1	*
VF3XBR0150T0054L050	1.5	3	0.9°	2	50	5	1.7°	4.31	100	6	3	●	1	—	51.0	*	*
VF3XBR0150T0054L060	1.5	3	0.9°	2	60	5	2.3°	4.63	110	8	3	●	1	—	61.1	64.2	*
VF3XBR0150T0054L070	1.5	3	0.9°	2	70	5	2.0°	4.94	120	8	3	●	1	—	71.1	74.8	*
VF3XBR0150T0130L040	1.5	3	1.5°	2	40	5	2.2°	4.73	80	6	3	★	1	—	—	41.9	*
VF3XBR0150T0130L050	1.5	3	1.5°	2	50	5	2.8°	5.26	110	8	3	●	1	—	—	52.2	*
VF3XBR0150T0130L060	1.5	3	1.5°	2	60	5	2.4°	5.78	110	8	3	●	1	—	—	62.4	*
VF3XBR0150T0130L070	1.5	3	1.5°	2	70	5	2.1°	6.30	120	8	3	●	1	—	—	72.7	*
VF3XBR0200T0054L030	2	4	0.9°	3	30	6	3.5°	4.65	90	8	3	●	1	—	30.9	32.5	34.2
VF3XBR0200T0054L040	2	4	0.9°	3	40	6	2.7°	4.97	90	8	3	●	1	—	41.0	43.0	*
VF3XBR0200T0054L050	2	4	0.9°	3	50	6	2.2°	5.28	110	8	3	●	1	—	51.0	53.6	*
VF3XBR0200T0054L060	2	4	0.9°	3	60	6	1.9°	5.60	110	8	3	●	1	—	61.1	*	*
VF3XBR0250T0054L035	2.5	5	0.9°	3.5	35	6.5	2.4°	5.80	90	8	3	★	1	—	35.9	37.7	*

* No interference

● : Inventory maintained. ★ : Inventory maintained in Japan.

(mm)

Order Number	RE	DC	BHTA2	APMX	LB2	LU	B2	BD2	LF	DCON	Flutes	Stock	Type	Effective length for inclined angle			
														0.5°	1°	2°	3°
VF3XBR0250T0054L040	2.5	5	0.9°	3.5	40	6.5	2.2°	5.95	90	8	3	●	1	—	41.0	43.0	*
VF3XBR0250T0054L050	2.5	5	0.9°	3.5	50	6.5	1.8°	6.27	110	8	3	●	1	—	51.0	*	*
VF3XBR0250T0054L060	2.5	5	0.9°	3.5	60	6.5	1.5°	6.58	110	8	3	●	1	—	61.1	*	*

* No interference

SOLID END MILLS

SQUARE

BALL

RADIUS

TAPER

BARREL

ROUGHING

IMPACT MIRACLE END MILLS

VF3XB

Ball nose, Taper neck, For hardened materials, 3 flute

CARBIDE

SOLID END MILLS

SQUARE

BALL

RADIUS

TAPER

BARREL

ROUGHING

RECOMMENDED CUTTING CONDITIONS

Work material			P						H						
			Carbon steel, Cast iron, Alloy steel (—30HRC) Cf53, GG25			Alloy steel, Tool steel, Pre-hardened steel X40CrMoV51			Hardened steel (45—55HRC) X40CrMoV51			Hardened steel (55—62HRC) X210Cr12			
RE (mm)	Taper angle one side BHTA2	Neck length LB2 (mm)	Revolution (min ⁻¹)	Feed rate (mm/min)	Depth of cut ap (mm)	Revolution (min ⁻¹)	Feed rate (mm/min)	Depth of cut ap (mm)	Revolution (min ⁻¹)	Feed rate (mm/min)	Depth of cut ap (mm)	Revolution (min ⁻¹)	Feed rate (mm/min)	Depth of cut ap (mm)	
R0.4	0.4°	6	34000	2700	0.03	31000	2200	0.025	24000	1700	0.02	19000	1400	0.015	
		8	31000	2100	0.02	29000	1700	0.02	22000	1300	0.015	18000	1000	0.01	
		12	28000	2000	0.015	26000	1600	0.01	20000	1200	0.01	16000	960	0.007	
	0.9°	8	31000	2200	0.02	29000	1800	0.02	22000	1400	0.015	18000	1100	0.01	
		12	28000	2100	0.015	26000	1700	0.01	20000	1300	0.01	16000	1000	0.007	
		16	25000	1100	0.01	23000	910	0.01	18000	700	0.008	14000	560	0.006	
R0.5	0.4°	8	27000	2700	0.04	25000	2200	0.04	19000	1700	0.03	15000	1400	0.02	
		10	24000	2200	0.03	22000	1800	0.025	17000	1400	0.02	14000	1100	0.015	
		12	24000	2200	0.03	22000	1800	0.025	17000	1400	0.02	14000	1100	0.015	
		16	22000	2100	0.03	21000	1700	0.025	16000	1300	0.02	13000	1000	0.015	
		20	20000	1400	0.015	18000	1200	0.01	14000	900	0.01	11000	720	0.007	
		25	18000	1300	0.015	17000	1000	0.01	13000	800	0.009	10000	640	0.006	
		30	15000	960	0.01	14000	780	0.01	11000	600	0.008	8800	480	0.006	
		35	14000	800	0.008	13000	650	0.007	10000	500	0.006	8000	400	0.004	
	0.9°	8	27000	2900	0.04	25000	2300	0.04	19000	1800	0.03	15000	1400	0.02	
		12	24000	2400	0.03	22000	2000	0.025	17000	1500	0.02	14000	1200	0.015	
		16	22000	2200	0.03	21000	1800	0.025	16000	1400	0.02	13000	1100	0.015	
		20	20000	1600	0.015	18000	1300	0.01	14000	1000	0.01	11000	800	0.007	
		25	18000	1400	0.015	17000	1200	0.01	13000	900	0.009	10000	720	0.006	
		30	15000	1100	0.01	14000	910	0.009	11000	700	0.008	8800	560	0.006	
		35	14000	960	0.008	13000	780	0.007	10000	600	0.006	8000	480	0.004	
		40	11000	800	0.007	11000	650	0.006	8000	500	0.005	6400	400	0.003	
	1.5°	50	8400	610	0.006	7800	490	0.005	6000	380	0.004	4800	300	0.003	
		60	7000	510	0.004	6500	400	0.004	5000	320	0.003	4000	260	0.002	
		70	7000	480	0.003	6500	390	0.002	5000	300	0.002	4000	240	0.001	
		12	24000	2600	0.03	22000	2100	0.025	17000	1600	0.02	14000	1300	0.015	
		16	22000	2400	0.03	21000	2000	0.025	16000	1500	0.02	13000	1200	0.015	
		20	20000	1800	0.015	18000	1400	0.01	14000	1100	0.01	11000	880	0.007	
	R0.75	0.4°	15	17000	2400	0.04	16000	2000	0.04	12000	1500	0.03	9600	1200	0.02
			20	17000	2100	0.03	16000	1700	0.025	12000	1300	0.02	9600	1000	0.015
30			14000	1600	0.015	13000	1300	0.01	10000	1000	0.01	8000	800	0.007	
40			13000	1300	0.01	12000	1000	0.01	9000	800	0.008	7200	640	0.006	
0.9°		15	17000	2400	0.04	16000	2000	0.04	12000	1500	0.03	9600	1200	0.02	
		20	17000	2200	0.03	16000	1800	0.025	12000	1400	0.02	9600	1100	0.015	
		30	14000	1800	0.015	13000	1400	0.01	10000	1100	0.01	8000	880	0.007	
		40	13000	1300	0.01	12000	1000	0.01	9000	800	0.008	7200	640	0.006	
1.5°		15	17000	2600	0.04	16000	2100	0.04	12000	1600	0.03	9600	1300	0.02	
		20	17000	2400	0.03	16000	2000	0.025	12000	1500	0.02	9600	1200	0.015	
		30	14000	2000	0.015	13000	1600	0.01	10000	1200	0.01	8000	960	0.007	
		40	14000	2000	0.015	13000	1600	0.01	10000	1200	0.01	8000	960	0.007	

Depth of cut

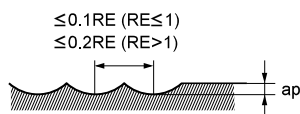

RE:Radius

Note 1) If the depth of cut is shallow, the revolution and feed rate can be increased.

Note 2) If the rigidity of the machine or the work materials installation is very low, or chattering and noise are generated, reduce the revolution and feed rate proportionately.

Work material			P						H					
			Carbon steel, Cast iron, Alloy steel (–30HRC) Cf53, GG25			Alloy steel, Tool steel, Pre-hardened steel X40CrMoV51			Hardened steel (45–55HRC) X40CrMoV51			Hardened steel (55–62HRC) X210Cr12		
RE (mm)	Taper angle one side BHTA2	Neck length LB2 (mm)	Revolution (min ⁻¹)	Feed rate (mm/min)	Depth of cut ap (mm)	Revolution (min ⁻¹)	Feed rate (mm/min)	Depth of cut ap (mm)	Revolution (min ⁻¹)	Feed rate (mm/min)	Depth of cut ap (mm)	Revolution (min ⁻¹)	Feed rate (mm/min)	Depth of cut ap (mm)
R1	0.4°	16	15000	3200	0.07	14000	2600	0.06	11000	2000	0.05	8800	1600	0.03
		20	14000	2400	0.06	13000	2000	0.05	10000	1500	0.04	8000	1200	0.03
		25	14000	2100	0.04	13000	1700	0.04	10000	1300	0.03	8000	1000	0.02
		30	13000	1800	0.03	12000	1400	0.03	9000	1100	0.025	7200	880	0.02
		35	13000	1600	0.03	12000	1300	0.025	9000	1000	0.02	7200	800	0.015
		40	12000	1400	0.015	11000	1200	0.01	8500	900	0.01	6800	720	0.007
	0.9°	20	14000	2600	0.06	13000	2100	0.05	10000	1600	0.04	8000	1300	0.03
		25	14000	2200	0.05	13000	1800	0.04	10000	1400	0.03	8000	1100	0.025
		30	13000	1900	0.04	12000	1600	0.04	9000	1200	0.03	7200	960	0.02
		35	13000	1800	0.04	12000	1400	0.03	9000	1100	0.025	7200	880	0.02
		40	12000	1600	0.03	11000	1300	0.025	8500	1000	0.02	6800	800	0.015
		50	11000	1400	0.015	10000	1200	0.01	8000	900	0.01	6400	720	0.007
		60	9800	1100	0.007	9100	910	0.006	7000	700	0.005	5600	560	0.003
	1.5°	70	8400	960	0.004	7800	780	0.004	6000	600	0.003	4800	480	0.002
		25	14000	2400	0.05	13000	2000	0.04	10000	1500	0.03	8000	1200	0.025
		30	12600	2100	0.04	12000	1700	0.04	9000	1300	0.03	7200	1000	0.02
		35	13000	1900	0.04	12000	1600	0.03	9000	1200	0.025	7200	960	0.02
	R1.25	0.9°	20	13000	2900	0.06	12000	2300	0.05	9000	1800	0.04	7200	1400
30			12000	2600	0.05	11000	2100	0.04	8500	1600	0.03	6800	1300	0.025
40			11000	2200	0.04	9800	1800	0.04	7500	1400	0.03	6000	1100	0.02
1.5°		20	13000	3000	0.06	12000	2500	0.05	9000	1900	0.04	7200	1500	0.03
		30	12000	2700	0.05	11050	2200	0.04	8500	1700	0.03	6800	1400	0.025
40	11000	2400	0.04	9800	2000	0.04	7500	1500	0.03	6000	1200	0.02		
R1.5	0.4°	20	12000	3700	0.13	11000	3000	0.1	8500	2300	0.09	6800	1800	0.06
		30	11000	2900	0.07	10000	2300	0.06	8000	1800	0.05	6400	1400	0.03
		40	11000	2400	0.06	10000	2000	0.05	8000	1500	0.04	6400	1200	0.03
		50	11000	2000	0.04	9800	1600	0.04	7500	1200	0.03	6000	960	0.02
	0.9°	20	12000	3800	0.13	11000	3100	0.1	8500	2400	0.09	6800	1900	0.06
		30	11000	3000	0.07	10000	2500	0.06	8000	1900	0.05	6400	1500	0.03
		40	11000	2600	0.06	10000	2100	0.05	8000	1600	0.04	6400	1300	0.03
		50	11000	2100	0.04	9800	1700	0.04	7500	1300	0.03	6000	1000	0.02
		60	9800	2000	0.03	9100	1600	0.025	7000	1200	0.02	5600	960	0.015
	1.5°	70	9800	1800	0.015	9100	1400	0.01	7000	1100	0.01	5600	880	0.007
		50	11000	2200	0.04	9800	1800	0.04	7500	1400	0.03	6000	1100	0.02
		60	9800	2100	0.03	9100	1700	0.025	7000	1300	0.02	5600	1000	0.015
70	9800	2000	0.015	9100	1600	0.01	7000	1200	0.01	5600	960	0.007		
R2	0.9°	30	10000	3200	0.3	9400	2600	0.25	7200	2000	0.2	5800	1600	0.15
		40	9500	2400	0.15	8800	2000	0.12	6800	1500	0.1	5400	1200	0.07
		50	9500	2100	0.1	8800	1700	0.1	6800	1300	0.08	5400	1000	0.06
		60	9000	1900	0.07	8300	1600	0.06	6400	1200	0.05	5100	960	0.03
R2.5	0.9°	35	8000	3500	0.3	7400	2900	0.25	5700	2200	0.2	4600	1800	0.15
		40	8000	3200	0.2	7400	2600	0.18	5700	2000	0.15	4600	1600	0.1
		60	7600	2400	0.15	7000	2000	0.12	5400	1500	0.1	4300	1200	0.07

Depth of cut

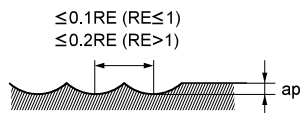

RE:Radius

Note 1) If the depth of cut is shallow, the revolution and feed rate can be increased.

Note 2) If the rigidity of the machine or the work materials installation is very low, or chattering and noise are generated, reduce the revolution and feed rate proportionately.

IMPACT MIRACLE END MILLS

VF2MV

End mill, Medium cut length, Irregular helix, 2 flute



CARBIDE

Carbon Steel, Alloy Steel, Cast Iron (<30HRC)	Tool Steel, Pre-Hardened Steel, Hardened Steel (≤45HRC)	Hardened Steel (≤55HRC)	Hardened Steel (>55HRC)	Austenitic Stainless Steel	Titanium Alloy, Heat Resistant Alloy	Copper Alloy	Aluminium Alloy
	○	◎	◎				

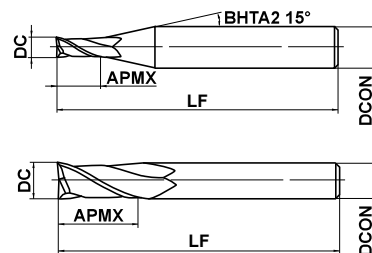

Type1

Type2

SOLID END MILLS



$0.5 \leq DC \leq 6$				
0				
-0.020				



$4 \leq DCON \leq 6$				
0				
-0.008				

● An irregular helix 2 flute square end mill suitable for high-speed machining of hardened steel.

(mm)

Order Number	DC	APMX	LF	DCON	Flutes	Stock	Type
VF2MVD0050	0.5	1.3	40	4	2	●	1
VF2MVD0100	1	2.5	40	4	2	●	1
VF2MVD0150	1.5	3.8	40	4	2	●	1
VF2MVD0200	2	5	40	4	2	●	1
VF2MVD0250	2.5	6.3	40	4	2	●	1
VF2MVD0300	3	7.5	50	6	2	●	1
VF2MVD0400	4	10	50	6	2	●	1
VF2MVD0500	5	12.5	50	6	2	●	1
VF2MVD0600	6	15	50	6	2	●	2

SQUARE

BALL

RADIUS

TAPER

BARREL

ROUGHING

● : Inventory maintained.

RECOMMENDED CUTTING CONDITIONS

Work material	P			H			H		
	Alloy steel, Tool steel, Pre-hardened steel X40CrMoV51			Hardened steel (45—55HRC) X40CrMoV51			Hardened steel (55—62HRC) X210Cr12		
Dia. DC (mm)	Revolution (min ⁻¹)	Feed rate (mm/min)	Depth of cut (mm)	Revolution (min ⁻¹)	Feed rate (mm/min)	Depth of cut (mm)	Revolution (min ⁻¹)	Feed rate (mm/min)	Depth of cut (mm)
0.5	40000	1000	0.015	40000	960	0.015	30000	600	0.01
1	40000	2000	0.06	32000	1600	0.06	16000	550	0.05
1.5	40000	3000	0.12	32000	1900	0.08	10600	500	0.08
2	30000	3000	0.18	24000	1900	0.10	8100	400	0.1
2.5	24000	2600	0.25	19000	1600	0.13	6400	350	0.13
3	20000	2300	0.30	16000	1400	0.15	5400	300	0.15
4	15000	2000	0.40	12000	1200	0.20	4000	240	0.2
5	12000	1600	0.50	9000	900	0.25	3200	190	0.2
6	10000	1400	0.60	7000	700	0.30	2700	160	0.2

Depth of cut

≤Please refer to the list above for depth of cut.

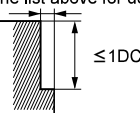
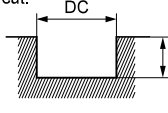
DC: Dia.

Note 1) When slotting, reduce the revolutions by 50—70% and the feed rate by 40—60%.

Note 2) For austenitic stainless steels, titanium and heat-resistant alloys, VQMHV type is recommended.

Note 3) The irregular helix flute end mill has a larger effect on controlling vibration when compared to standard end mills. However, if the rigidity of the machine or the workpiece installation is poor, vibration or abnormal sound can occur. In this case, please reduce the revolution and feed rate proportionately, or set a lower depth of cut.

IMPACT MIRACLE END MILLS

VF4MV

End mill, Medium cut length, Irregular helix, 4 flute



Carbon Steel, Alloy Steel, Cast Iron (<30HRC)	Tool Steel, Pre-Hardened Steel, Hardened Steel (≤45HRC)	Hardened Steel (≤55HRC)	Hardened Steel (>55HRC)	Austenitic Stainless Steel	Titanium Alloy, Heat Resistant Alloy	Copper Alloy	Aluminium Alloy
	○	◎	◎				

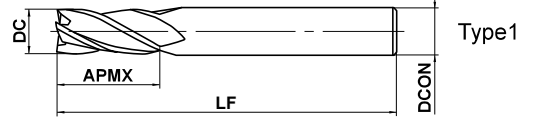

SOLID END MILLS

	DC ≤ 12	DC > 12			
	0 - 0.020	0 - 0.030			
	D CON = 6	8 ≤ D CON ≤ 10	12 ≤ D CON ≤ 16	D CON = 20	
	0 - 0.008	0 - 0.009	0 - 0.011	0 - 0.013	

● An irregular helix 4 flute square end mill suitable for high-speed machining of hardened steel.

(mm)

Order Number	DC	APMX	LF	D CON	Flutes	Stock	Type
VF4MVD0600	6	15	50	6	4	●	1
VF4MVD0800	8	20	60	8	4	●	1
VF4MVD1000	10	25	70	10	4	●	1
VF4MVD1200	12	30	90	12	4	●	1
VF4MVD1600	16	40	100	16	4	●	1
VF4MVD2000	20	50	110	20	4	●	1

SQUARE

BALL

RADIUS

RECOMMENDED CUTTING CONDITIONS

Work material	P			H			H			
	Dia. DC (mm)	Revolution (min ⁻¹)	Feed rate (mm/min)	Depth of cut (mm)	Revolution (min ⁻¹)	Feed rate (mm/min)	Depth of cut (mm)	Revolution (min ⁻¹)	Feed rate (mm/min)	Depth of cut (mm)
Alloy steel, Tool steel, Pre-hardened steel X40CrMoV51					Hardened steel (45—55HRC) X40CrMoV51			Hardened steel (55—62HRC) X210Cr12		
6	10000	2100	0.60	7000	1400	0.30	2700	320	0.20	
8	8000	1500	0.80	5600	1100	0.40	2000	240	0.20	
10	6400	1400	1.00	4500	950	0.50	1600	210	0.30	
12	5400	1200	1.00	3800	860	0.50	1300	160	0.30	
16	2400	550	3.00	1200	280	0.80	1000	130	0.30	
20	1900	480	4.00	1000	240	1.00	800	100	0.30	

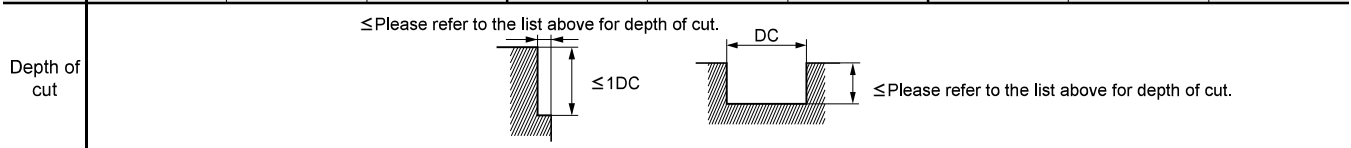

DC: Dia.

Note 1) When slotting, reduce the revolutions by 50—70% and the feed rate by 40—60%.

Note 2) For austenitic stainless steels, titanium and heat-resistant alloys, the VQMHV is recommended.

Note 3) The irregular helix flute end mill has a larger effect on controlling vibration when compared to standard end mills. However, if the rigidity of the machine or the workpiece installation is poor, vibration or abnormal sound can occur. In this case, please reduce the revolution and feed rate proportionately, or set a lower depth of cut.

● : Inventory maintained.

VF2XL

End mill, Long neck, 2 flute



CARBIDE

Carbon Steel, Alloy Steel, Cast Iron (<30HRC)	Tool Steel, Pre-Hardened Steel, Hardened Steel (≤45HRC)	Hardened Steel (≤55HRC)	Hardened Steel (>55HRC)	Austenitic Stainless Steel	Titanium Alloy, Heat Resistant Alloy	Copper Alloy	Aluminium Alloy
○	◎	◎	◎				

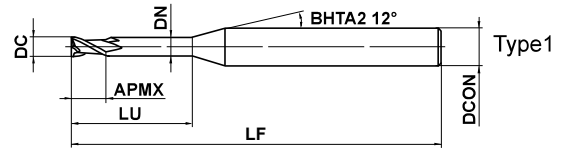

	0.1 ≤ DC ≤ 3				
	0 - 0.020				
	4 ≤ DCON ≤ 6				
	0 - 0.008				

● 2 flute long neck end mill for high-speed machining of hardened steels.

Order Number	DC	APMX	LU	DN	LF	DCON	Flutes	Stock	Type
VF2XLD0020N006	0.2	0.3	0.6	0.17	45	4	2	●	1
VF2XLD0030N010	0.3	0.5	1	0.27	45	4	2	●	1
VF2XLD0040N010	0.4	0.6	1	0.36	45	4	2	●	1
VF2XLD0040N020	0.4	0.6	2	0.36	45	4	2	●	1
VF2XLD0050N020	0.5	0.8	2	0.46	45	4	2	●	1
VF2XLD0050N040	0.5	0.8	4	0.46	45	4	2	●	1
VF2XLD0060N020	0.6	0.9	2	0.56	45	4	2	●	1
VF2XLD0060N040	0.6	0.9	4	0.56	45	4	2	●	1
VF2XLD0080N040	0.8	1.2	4	0.76	45	4	2	●	1
VF2XLD0080N060	0.8	1.2	6	0.76	45	4	2	●	1
VF2XLD0100N040	1	1.5	4	0.94	50	4	2	●	1
VF2XLD0100N060	1	1.5	6	0.94	50	4	2	●	1
VF2XLD0100N080	1	1.5	8	0.94	50	4	2	●	1
VF2XLD0100N120	1	1.5	12	0.94	50	4	2	●	1
VF2XLD0150N060	1.5	2.3	6	1.44	50	4	2	●	1
VF2XLD0150N080	1.5	2.3	8	1.44	50	4	2	●	1
VF2XLD0150N100	1.5	2.3	10	1.44	50	4	2	●	1
VF2XLD0150N120	1.5	2.3	12	1.44	50	4	2	●	1
VF2XLD0150N160	1.5	2.3	16	1.44	60	4	2	●	1
VF2XLD0200N060	2	3	6	1.9	50	4	2	●	1
VF2XLD0200N100	2	3	10	1.9	50	4	2	●	1
VF2XLD0200N120	2	3	12	1.9	50	4	2	●	1
VF2XLD0200N160	2	3	16	1.9	60	4	2	●	1
VF2XLD0200N200	2	3	20	1.9	60	4	2	●	1
VF2XLD0300N120	3	4.5	12	2.9	50	6	2	●	1
VF2XLD0300N200	3	4.5	20	2.9	60	6	2	●	1

(mm)

SOLID END MILLS

SQUARE

BALL

RADIUS

TAPER

BARREL

ROUGHING

IMPACT MIRACLE END MILLS

VF2XL

End mill, Long neck, 2 flute

CARBIDE

SOLID END MILLS

SQUARE

BALL

RADIUS

TAPER

BARREL

ROUGHING

RECOMMENDED CUTTING CONDITIONS

Work material		H					
		Hardened steel (45—55HRC)			Hardened steel (55—62HRC)		
		X40CrMoV51			X210Cr12		
Dia. DC (mm)	Neck length LU (mm)	Revolution (min ⁻¹)	Feed rate (mm/min)	Depth of cut per pass ap (mm)	Revolution (min ⁻¹)	Feed rate (mm/min)	Depth of cut per pass ap (mm)
0.2	0.6	40000	400	0.004	40000	360	0.004
	1	40000	300	0.003	40000	250	0.002
	1.5	40000	200	0.002	40000	150	0.001
0.3	1	40000	500	0.006	40000	450	0.004
	2	40000	400	0.003	38000	350	0.002
	3	38000	250	0.002	36000	200	0.001
0.4	1	40000	800	0.008	36000	500	0.006
	2	40000	500	0.007	30000	350	0.005
	4	36000	300	0.004	27000	200	0.003
0.5	2	40000	800	0.01	30000	600	0.009
	4	36000	600	0.008	27000	450	0.007
	6	30000	400	0.005	22000	300	0.004
0.6	2	40000	1000	0.015	30000	700	0.012
	4	36000	800	0.01	27000	500	0.01
	6	30000	600	0.006	22000	350	0.006
0.8	4	36000	1200	0.03	27000	900	0.02
	6	30000	900	0.02	22000	650	0.015
	8	24000	600	0.01	18000	450	0.008
	10	20000	400	0.008	15000	300	0.005
1	4	32000	1600	0.05	24000	1100	0.04
	6	32000	1400	0.04	24000	1000	0.03
	8	28000	1000	0.03	21000	750	0.02
	10	28000	800	0.02	21000	600	0.015
	12	24000	500	0.02	18000	370	0.01
1.5	6	22000	1200	0.08	16000	900	0.06
	8	22000	1100	0.07	16000	800	0.05
	10	22000	1000	0.06	16000	750	0.04
	12	20000	800	0.05	15000	600	0.03
	16	18000	500	0.03	13000	350	0.02
2	6	16000	1000	0.15	12000	750	0.15
	8	16000	1000	0.15	12000	750	0.1
	10	16000	800	0.1	12000	600	0.08
	12	16000	800	0.08	12000	600	0.06
	16	15000	600	0.06	11000	450	0.05
	20	14000	500	0.05	10000	350	0.04
3	12	11000	800	0.2	8200	600	0.15
	16	11000	600	0.15	8200	450	0.15
	20	11000	500	0.1	8200	350	0.1

Depth of cut

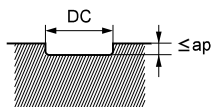

DC: Dia.

Note 1) If the depth of cut is shallow, the revolution and feed rate can be increased.

Note 2) Cutting conditions may be considerably different due to the overhang (milling depth), depth of cut, and machine tool. Please see the above table as a standard.

VFSD

End mill, Short cut length,
For hardened materials, 4/6 flutes



CARBIDE

Carbon Steel, Alloy Steel, Cast Iron (<30HRC)	Tool Steel, Pre-Hardened Steel, Hardened Steel (≤45HRC)	Hardened Steel (≤55HRC)	Hardened Steel (>55HRC)	Austenitic Stainless Steel	Titanium Alloy, Heat Resistant Alloy	Copper Alloy	Aluminium Alloy
	○	◎	◎				

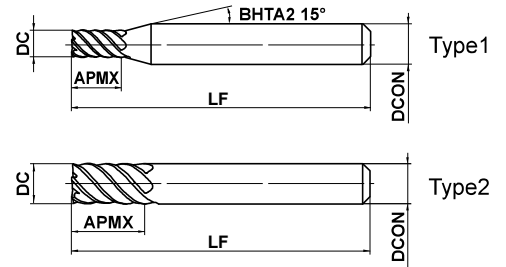

	1 ≤ DC ≤ 12				
	0 - 0.02				
	DCON=6	8 ≤ DCON ≤ 10	DCON=12		
	0 - 0.008	0 - 0.009	0 - 0.011		

● End mill with IMPACT MIRACLE coating for high hardened materials.

(mm)

Order Number	DC	APMX	LF	DCON	Flutes	Stock	Type
VFSD0100	1	2	45	6	4	●	1
VFSD0150	1.5	3	45	6	4	●	1
VFSD0200	2	4	45	6	4	●	1
VFSD0250	2.5	5	45	6	4	●	1
VFSD0300	3	6	45	6	6	●	1
VFSD0350	3.5	7	45	6	6	●	1
VFSD0400	4	8	45	6	6	●	1
VFSD0500	5	10	50	6	6	●	1
VFSD0600	6	12	50	6	6	●	2
VFSD0800	8	16	60	8	6	●	2
VFSD1000	10	20	70	10	6	●	2
VFSD1200	12	24	75	12	6	●	2

SOLID END MILLS

SQUARE

BALL

RADIUS

TAPER

BARREL

ROUGHING

● : Inventory maintained.

IMPACT MIRACLE END MILLS

VFMD

End mill, Medium cut length,
For hardened materials, 4/6 flutes



DC < 3

DC ≥ 3

DC < 3

DC ≥ 3

Carbon Steel, Alloy Steel, Cast Iron (<30HRC)	Tool Steel, Pre-Hardened Steel, Hardened Steel (≤45HRC)	Hardened Steel (≤55HRC)	Hardened Steel (>55HRC)	Austenitic Stainless Steel	Titanium Alloy, Heat Resistant Alloy	Copper Alloy	Aluminium Alloy
	○	◎	◎				

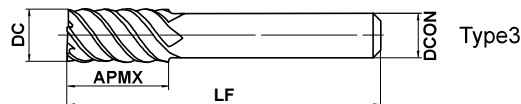
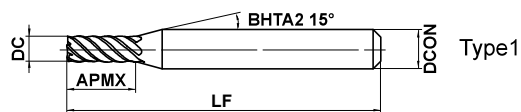

SOLID END MILLS



DC ≤ 12	DC > 12			
0 - 0.02	0 - 0.03			
DCON=6	8 ≤ DCON ≤ 10	12 ≤ DCON ≤ 16	20 ≤ DCON ≤ 25	
0 - 0.008	0 - 0.009	0 - 0.011	0 - 0.013	

● End mill with IMPACT MIRACLE coating for high hardened materials.

(mm)

Order Number	DC	APMX	LF	DCON	Flutes	Stock	Type
VFMD0100	1	3.5	60	6	4	●	1
VFMD0150	1.5	5	60	6	4	●	1
VFMD0200	2	7	60	6	4	●	1
VFMD0250	2.5	8	60	6	4	●	1
VFMD0300	3	10	60	6	6	●	1
VFMD0400	4	12	60	6	6	●	1
VFMD0500	5	15	60	6	6	●	1
VFMD0600	6	15	60	6	6	●	2
VFMD0800	8	20	75	8	6	●	2
VFMD1000	10	25	80	10	6	●	2
VFMD1200	12	30	100	12	6	●	2
VFMD1400	14	35	105	12	6	●	3
VFMD1500	15	40	110	16	6	●	1
VFMD1600	16	40	110	16	6	●	2
VFMD1800	18	40	120	16	6	●	3
VFMD2000	20	45	125	20	6	●	2
VFMD2200	22	45	135	20	6	●	3
VFMD2500	25	60	160	25	6	●	2

SQUARE

BALL

RADIUS

TAPER

BARREL

ROUGHING

● : Inventory maintained.

VFSD

End mill, Short cut length, 4/6 flutes,
For hardened materials

VFMD

End mill, Medium cut length, 4/6 flute,
For hardened materials

CARBIDE

RECOMMENDED CUTTING CONDITIONS

Work material	H								
	Hardened steel (45—55HRC)			Hardened steel (55—62HRC)			Hardened steel (62—70HRC)		
	X40CrMoV51			X210Cr12			1.3343 (W6Mo5Cr4V2)		
Dia. DC (mm)	Revolution (min ⁻¹)	Feed rate (mm/min)	Depth of cut (mm)	Revolution (min ⁻¹)	Feed rate (mm/min)	Depth of cut (mm)	Revolution (min ⁻¹)	Feed rate (mm/min)	Depth of cut (mm)
1	40000	1200	0.05	40000	800	0.03	32000	500	0.02
2	40000	2000	0.1	24000	1000	0.05	16000	600	0.05
3	32000	3800	0.2	16000	1900	0.1	11000	1200	0.05
4	24000	4400	0.2	12000	2200	0.1	8000	1300	0.05
6	16000	5800	0.3	8000	2900	0.2	5300	1800	0.1
8	12000	5800	0.4	6000	2900	0.2	4000	1800	0.1
10	9600	5800	0.5	4800	2900	0.3	3200	1800	0.2
12	8000	4800	0.6	4000	2400	0.3	2700	1500	0.2
16	6000	3600	0.8	3000	1800	0.5	2000	1100	0.3
20	4800	2900	1.0	2400	1400	0.5	1600	880	0.3
25	3800	2300	1.0	1900	1100	0.5	1300	720	0.3

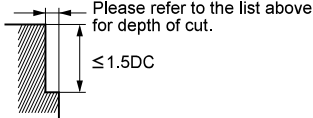
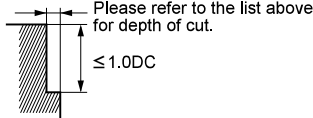
Depth of cut		
--------------	--	---

DC:Dia.

Slot milling with small diameter tools

Work material	H					
	Hardened steel (45—55HRC)			Hardened steel (55—62HRC)		
	X40CrMoV51			X210Cr12		
Dia. DC (mm)	Revolution (min ⁻¹)	Feed rate (mm/min)	Depth of cut (mm)	Revolution (min ⁻¹)	Feed rate (mm/min)	Depth of cut (mm)
1	15000	300	0.1	9500	110	0.05
2	8000	320	0.2	4800	190	0.1

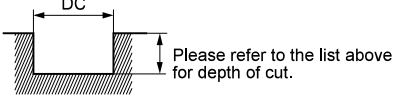
Depth of cut	
--------------	---

DC:Dia.

Note 1) If the depth of cut is shallow, the revolution and feed rate can be increased.

Note 2) If the rigidity of the machine or the work materials installation is very low, or chattering and noise are generated, reduce the revolution and feed rate proportionately.

SOLID END MILLS

SQUARE

BALL

RADIUS

TAPER

BARREL

ROUGHING

IMPACT MIRACLE END MILLS

VFFDRB

Duplex corner radius end mill, Short cut length, 4-6 flutes



Carbon Steel, Alloy Steel, Cast Iron (<30HRC)	Tool Steel, Pre-Hardened Steel, Hardened Steel (≤45HRC)	Hardened Steel (≤55HRC)	Hardened Steel (>55HRC)	Austenitic Stainless Steel	Titanium Alloy, Heat Resistant Alloy	Copper Alloy	Aluminium Alloy
	○	◎	◎				

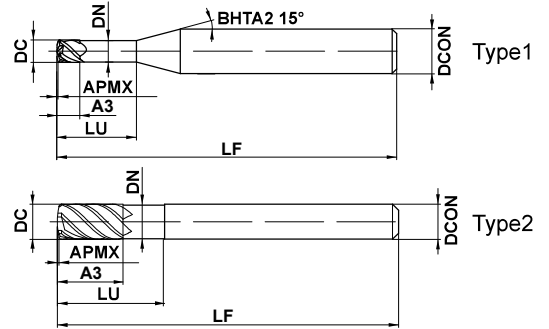
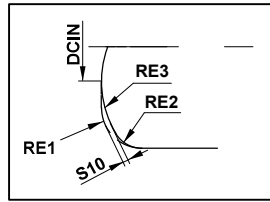

	DC ≤ 12			
	0 - 0.020			
	DCON=6	8 ≤ DCON ≤ 10	DCON=12	
	0 - 0.008	0 - 0.009	0 - 0.011	

- High feed rate possible due to the duplex corner radius geometry.
- Multi-flutes enable high feed machining.

(mm)

Order Number	DC	RE1	APMX	A3	LU	DN	LF	DCON	Flutes	Duplex corner radius				RMPX	Stock	Type
										S10	DCIN	RE2	RE3			
VFFDRBD0300	3	0.64	0.18	3	10	2.8	60	6	4	0.08	0.75	0.5	2	2.1°	●	1
VFFDRBD0400	4	0.71	0.25	4	12	3.8	60	6	4	0.13	1	0.5	3	1.9°	●	1
VFFDRBD0600	6	0.92	0.36	9	18	5.6	80	6	4	0.21	1.5	0.6	5	1.7°	●	2
VFFDRBD0800	8	1.16	0.44	12	24	7.6	90	8	6	0.22	3.2	0.8	4.5	1.7°	●	2
VFFDRBD1000	10	1.47	0.57	15	30	9.4	100	10	6	0.28	4	1	5.5	1.7°	●	2
VFFDRBD1200	12	1.77	0.7	18	36	11.4	110	12	6	0.34	4.8	1.2	6.5	1.8°	●	2

● : Inventory maintained.

RECOMMENDED CUTTING CONDITIONS

■ Side milling

Work material	P						P					
	Carbon steel, Alloy steel (180—280HB), Alloy tool steel ($\leq 350\text{HB}$), Mild steel ($\leq 180\text{HB}$)						Prehardened steel (35—45HRC)					
Dia. DC (mm)	Cutting speed (m/min)	Main spindle revolution (min^{-1})	Feed per tooth (mm/t)	Table feed per Min. (mm/min)	Depth of cut a_p (mm)	Depth of cut a_e (mm)	Cutting speed (m/min)	Main spindle revolution (min^{-1})	Feed per tooth (mm/t)	Table feed per Min. (mm/min)	Depth of cut a_p (mm)	Depth of cut a_e (mm)
3	150	16000	0.15	9600	0.12	1.5	135	14000	0.15	8400	0.12	1.5
4	150	12000	0.20	9600	0.16	2.0	135	11000	0.20	8800	0.16	2.0
6	150	8000	0.35	11000	0.24	3.0	135	7200	0.35	10000	0.24	3.0
8	150	6000	0.35	13000	0.32	4.8	135	5400	0.35	11000	0.32	4.8
10	150	4800	0.40	12000	0.40	6.0	135	4300	0.40	10000	0.40	6.0
12	150	4000	0.45	11000	0.48	7.2	135	3600	0.45	9700	0.48	7.2

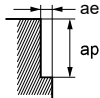
Depth of cut 

Work material	H			M			H					
	Hardened steel (40—55HRC), Ferritic and martensitic stainless steel ($>200\text{HB}$), Precipitation hardening stainless steel ($<450\text{HB}$)						Hardened steel (55—62HRC)					
Dia. DC (mm)	Cutting speed (m/min)	Main spindle revolution (min^{-1})	Feed per tooth (mm/t)	Table feed per Min. (mm/min)	Depth of cut a_p (mm)	Depth of cut a_e (mm)	Cutting speed (m/min)	Main spindle revolution (min^{-1})	Feed per tooth (mm/t)	Table feed per Min. (mm/min)	Depth of cut a_p (mm)	Depth of cut a_e (mm)
3	120	13000	0.15	7800	0.12	1.5	80	8500	0.10	3400	0.12	1.5
4	120	9500	0.21	8000	0.16	2.0	80	6400	0.15	3800	0.16	2.0
6	120	6400	0.35	9000	0.24	3.0	80	4200	0.30	5000	0.24	3.0
8	120	4800	0.35	10000	0.32	4.8	80	3200	0.30	5800	0.32	4.8
10	120	3800	0.40	9100	0.40	6.0	80	2500	0.35	5300	0.40	6.0
12	120	3200	0.45	8600	0.48	7.2	80	2100	0.40	5000	0.48	7.2

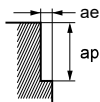
Depth of cut 

Note 1) When ramping, it is recommended to reduce the feed rate by 50%. The recommended ramping angle is 1 deg.

Note 2) When the overhang is longer than $5xD$, reduce the spindle speed by 30% and the feed rate by 50%.

IMPACT MIRACLE END MILLS

VFSDRB

Corner radius, Short cut length, For hardened materials, 6 flute



Carbon Steel, Alloy Steel, Cast Iron (<30HRC)	Tool Steel, Pre-Hardened Steel, Hardened Steel (≤45HRC)	Hardened Steel (≤55HRC)	Hardened Steel (>55HRC)	Austenitic Stainless Steel	Titanium Alloy, Heat Resistant Alloy	Copper Alloy	Aluminium Alloy
	○	◎	◎				

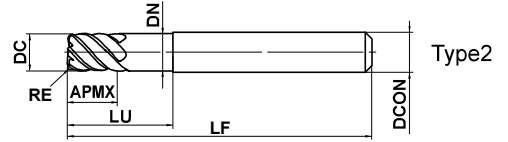
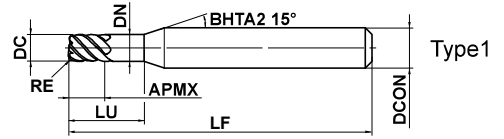

	3 ≤ DC ≤ 12				
	⁰ / _{-0.02}				
	DCON=6	8 ≤ DCON ≤ 10	DCON=12		
	⁰ / _{-0.008}	⁰ / _{-0.009}	⁰ / _{-0.011}		

● 6 flute end mill with IMPACT MIRACLE coating for high hardened materials.

(mm)

Order Number	DC	RE	APMX	LU	DN	LF	DCON	Flutes	Stock	Type
VFSDRBD0300R030	3	0.3	3	9	2.9	45	6	6	●	1
VFSDRBD0400R030	4	0.3	4	12	3.9	45	6	6	●	1
VFSDRBD0500R030	5	0.3	5	15	4.9	50	6	6	●	1
VFSDRBD0600R030	6	0.3	6	18	5.85	50	6	6	●	2
VFSDRBD0600R050	6	0.5	6	18	5.85	50	6	6	●	2
VFSDRBD0600R100	6	1	6	18	5.85	50	6	6	●	2
VFSDRBD0800R030	8	0.3	8	24	7.85	60	8	6	●	2
VFSDRBD0800R050	8	0.5	8	24	7.85	60	8	6	●	2
VFSDRBD0800R100	8	1	8	24	7.85	60	8	6	●	2
VFSDRBD1000R050	10	0.5	10	30	9.7	70	10	6	●	2
VFSDRBD1000R100	10	1	10	30	9.7	70	10	6	●	2
VFSDRBD1200R050	12	0.5	12	36	11.7	75	12	6	●	2
VFSDRBD1200R100	12	1	12	36	11.7	75	12	6	●	2

● : Inventory maintained.

VFMDRBD

Corner radius, Medium cut length, For hardened materials, 6 flute



CARBIDE

Carbon Steel, Alloy Steel, Cast Iron (<30HRC)	Tool Steel, Pre-Hardened Steel, Hardened Steel (≤45HRC)	Hardened Steel (≤55HRC)	Hardened Steel (>55HRC)	Austenitic Stainless Steel	Titanium Alloy, Heat Resistant Alloy	Copper Alloy	Aluminium Alloy
	○	◎	◎				

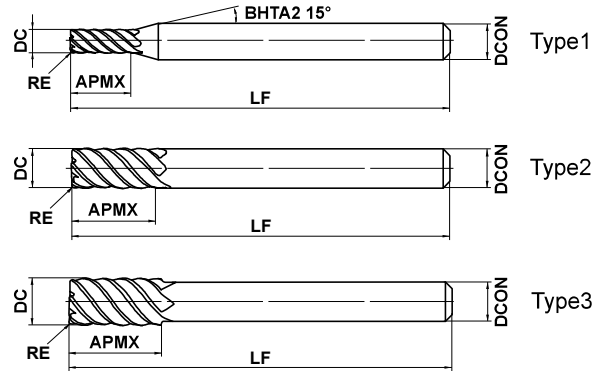

	DC ≤ 12	DC > 12			
	$\begin{matrix} 0 \\ -0.02 \end{matrix}$	$\begin{matrix} 0 \\ -0.03 \end{matrix}$			
	DCON = 6	8 ≤ DCON ≤ 10	12 ≤ DCON ≤ 16	DCON = 20	
	$\begin{matrix} 0 \\ -0.008 \end{matrix}$	$\begin{matrix} 0 \\ -0.009 \end{matrix}$	$\begin{matrix} 0 \\ -0.011 \end{matrix}$	$\begin{matrix} 0 \\ -0.013 \end{matrix}$	

● 6 flute corner radius end mill with IMPACT MIRACLE coating for high hardened materials.

(mm)

Order Number	DC	RE	APMX	LF	DCON	Flutes	Stock	Type
VFMDRBD0300R030	3	0.3	10	60	6	6	●	1
VFMDRBD0400R030	4	0.3	12	60	6	6	●	1
VFMDRBD0500R030	5	0.3	15	60	6	6	●	1
VFMDRBD0600R030	6	0.3	15	60	6	6	●	2
VFMDRBD0600R050	6	0.5	15	60	6	6	●	2
VFMDRBD0600R100	6	1	15	60	6	6	●	2
VFMDRBD0800R030	8	0.3	20	75	8	6	●	2
VFMDRBD0800R050	8	0.5	20	75	8	6	●	2
VFMDRBD0800R100	8	1	20	75	8	6	●	2
VFMDRBD1000R030	10	0.3	25	80	10	6	●	2
VFMDRBD1000R050	10	0.5	25	80	10	6	●	2
VFMDRBD1000R100	10	1	25	80	10	6	●	2
VFMDRBD1200R050	12	0.5	30	100	12	6	●	2
VFMDRBD1200R100	12	1	30	100	12	6	●	2
VFMDRBD1600R100	16	1	40	110	16	6	●	2
VFMDRBD1600R150	16	1.5	40	110	16	6	●	2
VFMDRBD1800R100	18	1	40	120	16	6	●	3
VFMDRBD1800R150	18	1.5	40	120	16	6	●	3
VFMDRBD2000R100	20	1	45	125	20	6	●	2
VFMDRBD2000R150	20	1.5	45	125	20	6	●	2
VFMDRBD2000R200	20	2	45	125	20	6	●	2

SOLID END MILLS

SQUARE

BALL

RADIUS

TAPER

BARREL

ROUGHING

IMPACT MIRACLE END MILLS

VFSDRB

Corner radius, Short cut length, For hardened materials, 6 flute

VFMDRB

Corner radius, Medium cut length, For hardened materials, 6 flute

RECOMMENDED CUTTING CONDITIONS

Work material	H								
	Hardened steel (45—55HRC)			Hardened steel (55—62HRC)			Hardened steel (62—70HRC)		
	X40CrMoV51			X210Cr12			070M55, 1.3343 (W6Mo5Cr4V2)		
Dia. DC (mm)	Revolution (min ⁻¹)	Feed rate (mm/min)	Depth of cut (mm)	Revolution (min ⁻¹)	Feed rate (mm/min)	Depth of cut (mm)	Revolution (min ⁻¹)	Feed rate (mm/min)	Depth of cut (mm)
3	32000	3800	0.2	16000	1900	0.1	11000	1200	0.05
4	24000	4400	0.2	12000	2200	0.1	8000	1300	0.05
6	16000	5800	0.3	8000	2900	0.2	5300	1800	0.1
8	12000	5800	0.4	6000	2900	0.2	4000	1800	0.1
10	9600	5800	0.5	4800	2900	0.3	3200	1800	0.2
12	8000	4800	0.6	4000	2400	0.3	2700	1500	0.2
16	6000	3600	0.8	3000	1800	0.5	2000	1100	0.3
20	4800	2900	1.0	2400	1400	0.5	1600	880	0.3

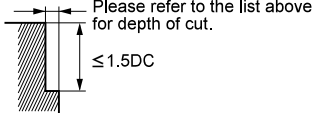
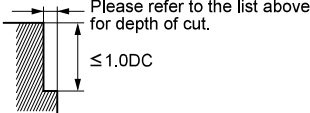
Depth of cut	Please refer to the list above for depth of cut.	
		$\leq 1.5DC$
	$\leq 1.0DC$	

DC: Dia.

CARBIDE

SOLID END MILLS

SQUARE

BALL

RADIUS

TAPER

BARREL

ROUGHING

VFHVRB

Corner radius, Short cut length, Irregular helix, 4 flute



CARBIDE

Carbon Steel, Alloy Steel, Cast Iron (<30HRC)	Tool Steel, Pre-Hardened Steel, Hardened Steel (≤45HRC)	Hardened Steel (≤55HRC)	Hardened Steel (>55HRC)	Austenitic Stainless Steel	Titanium Alloy, Heat Resistant Alloy	Copper Alloy	Aluminium Alloy
⊙	⊙	⊙	○	○	○		

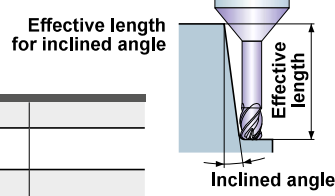
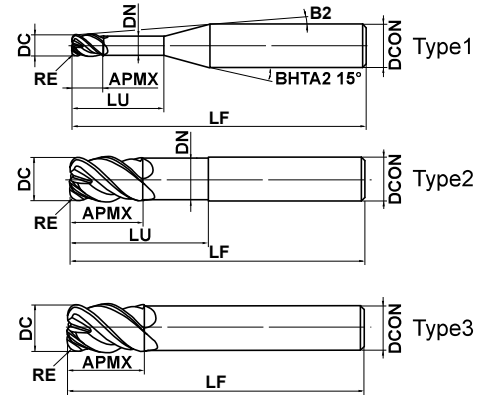

	DC ≤ 10	DC > 10			
	±0.007	±0.01			
	DC ≤ 12	DC > 12			
	⁰ / _{-0.02}	⁰ / _{-0.03}			
	DCON = 6	8 ≤ DCON ≤ 10	12 ≤ DCON ≤ 16		
	⁰ / _{-0.008}	⁰ / _{-0.009}	⁰ / _{-0.011}		

● IMPACT MIRACLE corner radius end mill for high feed and efficient machining.

Order Number	DC	RE	APMX	LU	DN	B2	LF	DCON	Flutes	Stock	Type	Effective length for inclined angle (mm)			
												0.5°	1°	2°	3°
VFHVRBD0100R02N004	1	0.2	1	4	0.94	10.6°	60	6	4	●	1	4.2	4.5	4.7	5.3
VFHVRBD0100R02N006	1	0.2	1	6	0.94	9.2°	60	6	4	●	1	6.4	6.7	7.2	7.7
VFHVRBD0100R02N008	1	0.2	1	8	0.94	8.2°	60	6	4	●	1	8.5	8.8	9.5	10.2
VFHVRBD0100R02N010	1	0.2	1	10	0.94	7.4°	60	6	4	●	1	10.5	11	11.8	12.7
VFHVRBD0100R02N015	1	0.2	1	15	0.94	5.9°	60	6	4	●	1	15.8	16.3	17.5	18.9
VFHVRBD0100R02N020	1	0.2	1	20	0.94	4.9°	80	6	4	●	1	20.9	21.7	23.3	25.1
VFHVRBD0150R03N004	1.5	0.3	1.5	4	1.44	10.3°	60	6	4	●	1	4.2	4.5	4.6	5.2
VFHVRBD0150R03N006	1.5	0.3	1.5	6	1.44	8.9°	60	6	4	●	1	6.3	6.6	7.2	7.7
VFHVRBD0150R03N010	1.5	0.3	1.5	10	1.44	7°	60	6	4	●	1	10.5	10.9	11.8	12.7
VFHVRBD0150R03N015	1.5	0.3	1.5	15	1.44	5.5°	60	6	4	●	1	15.7	16.3	17.5	18.9
VFHVRBD0150R03N020	1.5	0.3	1.5	20	1.44	4.6°	80	6	4	●	1	20.9	21.6	23.3	25.1
VFHVRBD0150R03N025	1.5	0.3	1.5	25	1.44	3.9°	80	6	4	●	1	26.1	27	29	31.3
VFHVRBD0150R03N030	1.5	0.3	1.5	30	1.44	3.4°	80	6	4	●	1	31.3	32.3	34.7	37.5
VFHVRBD0200R05N006	2	0.5	2	6	1.9	8.7°	60	6	4	●	1	6.3	6.5	7	7.5
VFHVRBD0200R05N010	2	0.5	2	10	1.9	6.7°	60	6	4	●	1	10.5	10.8	11.6	12.5
VFHVRBD0200R05N015	2	0.5	2	15	1.9	5.2°	60	6	4	●	1	15.6	16.2	17.4	18.7
VFHVRBD0200R05N020	2	0.5	2	20	1.9	4.3°	80	6	4	●	1	20.8	21.5	23.1	24.9
VFHVRBD0200R05N025	2	0.5	2	25	1.9	3.6°	80	6	4	●	1	26	26.9	28.9	31.2
VFHVRBD0200R05N030	2	0.5	2	30	1.9	3.1°	80	6	4	●	1	31.2	32.2	34.6	37.4
VFHVRBD0200R05N035	2	0.5	2	35	1.9	2.8°	90	6	4	●	1	36.3	37.6	40.4	*
VFHVRBD0200R05N040	2	0.5	2	40	1.9	2.5°	90	6	4	●	1	41.5	42.9	46.1	*
VFHVRBD0300R05N010	3	0.5	3	10	2.9	5.6°	60	6	4	●	1	10.5	10.8	11.6	12.5
VFHVRBD0300R05N015	3	0.5	3	15	2.9	4.3°	60	6	4	●	1	15.6	16.2	17.4	18.7
VFHVRBD0300R05N020	3	0.5	3	20	2.9	3.4°	80	6	4	●	1	20.8	21.5	23.1	24.9
VFHVRBD0300R05N030	3	0.5	3	30	2.9	2.5°	80	6	4	●	1	31.2	32.2	34.6	*
VFHVRBD0300R08N010	3	0.8	3	10	2.9	5.7°	60	6	4	●	1	10.4	10.8	11.6	12.4
VFHVRBD0300R08N015	3	0.8	3	15	2.9	4.3°	60	6	4	●	1	15.6	16.2	17.3	18.7
VFHVRBD0300R08N020	3	0.8	3	20	2.9	3.5°	80	6	4	●	1	20.8	21.5	23.1	24.9
VFHVRBD0300R08N030	3	0.8	3	30	2.9	2.5°	80	6	4	●	1	31.1	32.2	34.6	*
VFHVRBD0300R08N040	3	0.8	3	40	2.9	2°	90	6	4	★	1	41.5	42.9	*	*
VFHVRBD0300R08N050	3	0.8	3	50	2.9	1.6°	90	6	4	★	1	51.8	53.6	*	*
VFHVRBD0400R05N012	4	0.5	4	12	3.9	3.8°	60	6	4	●	1	12.5	13	13.9	15
VFHVRBD0400R05N020	4	0.5	4	20	3.9	2.5°	80	6	4	●	1	20.8	21.5	23.1	*
VFHVRBD0400R05N030	4	0.5	4	30	3.9	1.8°	80	6	4	●	1	31.2	32.2	*	*

* No interference

● : Inventory maintained. ★ : Inventory maintained in Japan.

SOLID END MILLS

SQUARE

BALL

RADIUS

TAPER

BARREL

ROUGHING

IMPACT MIRACLE END MILLS

VFHVRB

Corner radius, Short cut length, Irregular helix, 4 flute

(mm)

Order Number	DC	RE	APMX	LU	DN	B2	LF	DCON	Flutes	Stock	Type	Effective length for inclined angle			
												0.5°	1°	2°	3°
VFHVRBD0400R05N048	4	0.5	4	48	3.9	1.2°	90	6	4	●	1	49.8	51.5	*	*
VFHVRBD0400R10N012	4	1	4	12	3.9	3.9°	60	6	4	●	1	12.5	12.9	13.8	14.9
VFHVRBD0400R10N020	4	1	4	20	3.9	2.5°	80	6	4	●	1	20.8	21.5	23	*
VFHVRBD0400R10N030	4	1	4	30	3.9	1.8°	80	6	4	●	1	31.1	32.2	*	*
VFHVRBD0600R05N018	6	0.5	9	18	5.85	—	60	6	4	●	2	*	*	*	*
VFHVRBD0600R05N030	6	0.5	9	30	5.85	—	80	6	4	●	2	*	*	*	*
VFHVRBD0600R10N018	6	1	9	18	5.85	—	60	6	4	●	2	*	*	*	*
VFHVRBD0600R10N030	6	1	9	30	5.85	—	80	6	4	●	2	*	*	*	*
VFHVRBD0600R10N054	6	1	9	54	5.85	—	90	6	4	★	2	*	*	*	*
VFHVRBD0600R15N018	6	1.5	9	18	5.85	—	60	6	4	●	2	*	*	*	*
VFHVRBD0600R15N030	6	1.5	9	30	5.85	—	80	6	4	●	2	*	*	*	*
VFHVRBD0600R15N042	6	1.5	9	42	5.85	—	90	6	4	●	2	*	*	*	*
VFHVRBD0600R15N054	6	1.5	9	54	5.85	—	90	6	4	●	2	*	*	*	*
VFHVRBD0600R20N018	6	2	9	18	5.85	—	60	6	4	★	2	*	*	*	*
VFHVRBD0600R20N030	6	2	9	30	5.85	—	80	6	4	★	2	*	*	*	*
VFHVRBD0700R15	7	1.5	11	—	—	—	80	6	4	●	3	*	*	*	*
VFHVRBD0800R05N024	8	0.5	12	24	7.85	—	60	8	4	●	2	*	*	*	*
VFHVRBD0800R05N040	8	0.5	12	40	7.85	—	100	8	4	●	2	*	*	*	*
VFHVRBD0800R10N024	8	1	12	24	7.85	—	60	8	4	●	2	*	*	*	*
VFHVRBD0800R10N040	8	1	12	40	7.85	—	100	8	4	●	2	*	*	*	*
VFHVRBD0800R20N024	8	2	12	24	7.85	—	60	8	4	●	2	*	*	*	*
VFHVRBD0800R20N040	8	2	12	40	7.85	—	100	8	4	●	2	*	*	*	*
VFHVRBD0800R20N056	8	2	12	56	7.85	—	120	8	4	★	2	*	*	*	*
VFHVRBD0800R20N072	8	2	12	72	7.85	—	120	8	4	●	2	*	*	*	*
VFHVRBD0900R20	9	2	13.5	—	—	—	100	8	4	●	3	*	*	*	*
VFHVRBD1000R05N030	10	0.5	15	30	9.7	—	70	10	4	●	2	*	*	*	*
VFHVRBD1000R05N050	10	0.5	15	50	9.7	—	110	10	4	●	2	*	*	*	*
VFHVRBD1000R10N030	10	1	15	30	9.7	—	70	10	4	●	2	*	*	*	*
VFHVRBD1000R10N050	10	1	15	50	9.7	—	110	10	4	●	2	*	*	*	*
VFHVRBD1000R20N030	10	2	15	30	9.7	—	70	10	4	●	2	*	*	*	*
VFHVRBD1000R20N050	10	2	15	50	9.7	—	110	10	4	●	2	*	*	*	*
VFHVRBD1000R20N070	10	2	15	70	9.7	—	150	10	4	★	2	*	*	*	*
VFHVRBD1000R20N090	10	2	15	90	9.7	—	150	10	4	●	2	*	*	*	*
VFHVRBD1100R20	11	2	16.5	—	—	—	110	10	4	●	3	*	*	*	*
VFHVRBD1200R05N036	12	0.5	18	36	11.7	—	80	12	4	●	2	*	*	*	*
VFHVRBD1200R05N060	12	0.5	18	60	11.7	—	120	12	4	●	2	*	*	*	*
VFHVRBD1200R10N036	12	1	18	36	11.7	—	80	12	4	●	2	*	*	*	*
VFHVRBD1200R10N060	12	1	18	60	11.7	—	120	12	4	●	2	*	*	*	*
VFHVRBD1200R20N036	12	2	18	36	11.7	—	80	12	4	●	2	*	*	*	*
VFHVRBD1200R20N060	12	2	18	60	11.7	—	120	12	4	●	2	*	*	*	*
VFHVRBD1200R20N084	12	2	18	84	11.7	—	160	12	4	★	2	*	*	*	*
VFHVRBD1200R20N108	12	2	18	108	11.7	—	160	12	4	★	2	*	*	*	*
VFHVRBD1200R30N036	12	3	18	36	11.7	—	80	12	4	●	2	*	*	*	*
VFHVRBD1200R30N060	12	3	18	60	11.7	—	120	12	4	●	2	*	*	*	*
VFHVRBD1300R30	13	3	19.5	—	—	—	120	12	4	●	3	*	*	*	*
VFHVRBD1600R05N042	16	0.5	24	42	15.5	—	100	16	4	●	2	*	*	*	*
VFHVRBD1600R20N042	16	2	24	42	15.5	—	100	16	4	●	2	*	*	*	*
VFHVRBD1600R30N042	16	3	24	42	15.5	—	100	16	4	●	2	*	*	*	*
VFHVRBD1600R30N080	16	3	24	80	15.5	—	140	16	4	●	2	*	*	*	*
VFHVRBD1600R30N120	16	3	24	120	15.5	—	175	16	4	★	2	*	*	*	*

* No interference

● : Inventory maintained. ★ : Inventory maintained in Japan.

IMPACT MIRACLE END MILLS

VFHVRB

Corner radius, Short cut length, Irregular helix, 4 flute

CARBIDE

SOLID END MILLS
SQUARE
BALL
RADIUS
TAPER
BARREL
ROUGHING

Work material			P								H							
			Carbon steel, Cast iron, Alloy steel (–30HRC)				Alloy steel, Tool steel, Pre-hardened steel				Hardened steel (45–55HRC)				Hardened steel (55–62HRC)			
Cf53, GG25			X40CrMoV51								X40CrMoV51				X210Cr12			
Dia. DC (mm)	Corner R RE (mm)	Neck length LU (mm)	Revolution (min ⁻¹)	Feed rate (mm/min)	Depth of cut ap (mm)	Depth of cut ae (mm)	Revolution (min ⁻¹)	Feed rate (mm/min)	Depth of cut ap (mm)	Depth of cut ae (mm)	Revolution (min ⁻¹)	Feed rate (mm/min)	Depth of cut ap (mm)	Depth of cut ae (mm)	Revolution (min ⁻¹)	Feed rate (mm/min)	Depth of cut ap (mm)	Depth of cut ae (mm)
7	1.5	—	6800	13000	0.5	3	5600	9200	0.4	3	4600	7400	0.3	3	3400	3300	0.15	3
8	0.5	24	3000	3900	0.18	5	2500	2800	0.14	5	2000	2200	0.11	5	1500	1000	0.05	5
8	0.5	40	3000	3900	0.16	5	2500	2800	0.12	5	2000	2200	0.1	5	1500	1000	0.05	5
8	1	24	4200	6500	0.3	4.5	3500	4600	0.23	4.5	2800	3700	0.18	4.5	2100	1600	0.09	4.5
8	1	40	4200	6500	0.27	4.5	3500	4600	0.21	4.5	2800	3700	0.16	4.5	2100	1600	0.08	4.5
8	2	24	6000	13000	0.6	3	5000	9200	0.46	3	4000	7400	0.36	3	3000	3300	0.18	3
8	2	40	6000	13000	0.54	3	5000	9200	0.42	3	4000	7400	0.32	3	3000	3300	0.16	3
8	2	56	5000	11000	0.48	3	4200	7800	0.37	3	3400	6300	0.3	3	2500	2800	0.14	3
8	2	72	5000	11000	0.3	3	4200	7800	0.23	3	3400	6300	0.2	3	2500	2800	0.09	3
9	2	—	5300	13000	0.6	3.5	4400	9200	0.46	3.5	3600	7400	0.36	3.5	2700	3300	0.18	3.5
10	0.5	30	2400	3900	0.18	6.5	2000	2800	0.14	6.5	1600	2200	0.11	6.5	1200	1000	0.05	6.5
10	0.5	50	2400	3900	0.16	6.5	2000	2800	0.12	6.5	1600	2200	0.1	6.5	1200	1000	0.05	6.5
10	1	30	3300	6500	0.3	6	2700	4600	0.23	6	2200	3700	0.18	6	1700	1600	0.09	6
10	1	50	3300	6500	0.27	6	2700	4600	0.21	6	2200	3700	0.16	6	1700	1600	0.08	6
10	2	30	4800	13000	0.6	4.5	4000	9200	0.46	4.5	3200	7400	0.36	4.5	2400	3300	0.18	4.5
10	2	50	4800	13000	0.54	4.5	4000	9200	0.42	4.5	3200	7400	0.32	4.5	2400	3300	0.16	4.5
10	2	70	4000	11000	0.48	4.5	3300	7800	0.37	4.5	2700	6300	0.3	4.5	2000	2800	0.14	4.5
10	2	90	4000	11000	0.48	4.5	3300	7800	0.37	4.5	2700	6300	0.3	4.5	2000	2800	0.14	4.5
11	2	—	4300	12000	0.6	5	3600	8500	0.46	5	2900	6800	0.36	5	2200	3000	0.18	5
12	0.5	36	2000	3600	0.27	8	1700	2600	0.21	8	1300	2100	0.14	8	1000	900	0.07	8
12	0.5	60	2000	3600	0.24	8	1700	2600	0.18	8	1300	2100	0.12	8	1000	900	0.06	8
12	1	36	2400	4800	0.36	7.5	2000	3400	0.28	7.5	1600	2700	0.18	7.5	1200	1200	0.09	7.5
12	1	60	2400	4800	0.32	7.5	2000	3400	0.25	7.5	1600	2700	0.16	7.5	1200	1200	0.08	7.5
12	2	36	4000	12000	0.9	6	3300	8500	0.7	6	2700	6800	0.45	6	2000	3000	0.23	6
12	2	60	4000	12000	0.8	6	3300	8500	0.6	6	2700	6800	0.4	6	2000	3000	0.2	6
12	2	84	3300	9900	0.7	6	2700	7000	0.55	6	2200	5600	0.36	6	1700	2500	0.18	6
12	2	108	3300	9900	0.45	6	2700	7000	0.35	6	2200	5600	0.23	6	1700	2500	0.11	6
12	3	36	4000	12000	0.9	4.5	3300	8500	0.7	4.5	2700	6800	0.45	4.5	2000	3000	0.23	4.5
12	3	60	4000	12000	0.8	4.5	3300	8500	0.6	4.5	2700	6800	0.4	4.5	2000	3000	0.2	4.5
13	3	—	3700	12000	0.9	5	3100	8500	0.7	5	2500	6800	0.45	5	1900	3000	0.23	5
16	0.5	42	1500	3000	0.27	11	1200	2100	0.21	11	1000	1700	0.12	11	750	750	0.05	11
16	2	42	2100	5000	0.45	9	1700	3600	0.35	9	1400	2900	0.2	9	1100	1300	0.08	9
16	3	42	3000	10000	0.9	7.5	2500	7100	0.7	7.5	2000	5700	0.4	7.5	1500	2500	0.15	7.5
16	3	80	3000	10000	0.8	7.5	2500	7100	0.6	7.5	2000	5700	0.37	7.5	1500	2500	0.14	7.5
16	3	120	2500	8300	0.7	7.5	2100	5900	0.55	7.5	1700	4700	0.32	7.5	1300	2100	0.12	7.5
Depth of cut																		

Note 1) If the depth of cut is shallow, the revolution and feed rate can be increased.

Note 2) Air blow or oil mist is recommended for good chip evacuation.

Note 3) For profile machining such as moulds, machining conditions may differ considerably depending on the workpiece geometry, machining methods and depth of cut. Reduce the feed rate especially when machining the corner sections of a workpiece.

Note 4) The irregular helix flute end mill has a larger effect on controlling vibration when compared to standard end mills. However, if the rigidity of the machine or the workpiece installation is poor, vibration or abnormal sound can occur. In this case, please reduce the revolution and feed rate proportionately, or set a lower depth of cut.

IMPACT MIRACLE END MILLS

VFHVRB

Corner radius, Short cut length, Irregular helix, 4 flute

CARBIDE

SOLID END MILLS

SOLID END MILLS

SQUARE

BALL

RADIUS

TAPER

BARREL

ROUGHING

Work material			P								H							
			Carbon steel, Cast iron, Alloy steel (–30HRC)				Alloy steel, Tool steel, Pre-hardened steel				Hardened steel (45–55HRC)				Hardened steel (55–62HRC)			
			Cf53, GG25				X40CrMoV51				X40CrMoV51				X210Cr12			
Dia. DC (mm)	Corner R RE (mm)	Neck length LU (mm)	Revolution (min ⁻¹)	Feed rate (mm/min)	Depth of cut ap (mm)	Depth of cut ae (mm)	Revolution (min ⁻¹)	Feed rate (mm/min)	Depth of cut ap (mm)	Depth of cut ae (mm)	Revolution (min ⁻¹)	Feed rate (mm/min)	Depth of cut ap (mm)	Depth of cut ae (mm)	Revolution (min ⁻¹)	Feed rate (mm/min)	Depth of cut ap (mm)	Depth of cut ae (mm)
7	1.5	—	4100	3900	1	3	3400	2700	0.8	3	2700	2200	0.6	3	2100	980	0.2	3
8	0.5	24	1800	1200	0.35	5	1500	840	0.3	5	1200	670	0.2	5	900	300	0.07	5
8	0.5	40	1800	1200	0.3	5	1500	840	0.25	5	1200	670	0.2	5	900	300	0.06	5
8	1	24	2500	2000	0.6	4.5	2100	1400	0.5	4.5	1700	1100	0.4	4.5	1300	500	0.12	4.5
8	1	40	2500	2000	0.5	4.5	2100	1400	0.4	4.5	1700	1100	0.3	4.5	1300	500	0.11	4.5
8	2	24	3600	3900	1.2	3	3000	2700	1	3	2400	2200	0.7	3	1800	980	0.24	3
8	2	40	3600	3900	1.1	3	3000	2700	0.9	3	2400	2200	0.7	3	1800	980	0.22	3
8	2	56	3000	3300	1	3	2500	2300	0.8	3	2000	1800	0.6	3	1500	830	0.2	3
8	2	72	3000	3300	0.6	3	2500	2300	0.5	3	2000	1800	0.4	3	1500	830	0.12	3
9	2	—	3200	3900	1.2	3.5	2700	2700	1	3.5	2100	2200	0.7	3.5	1600	980	0.24	3.5
10	0.5	30	1400	1200	0.35	6.5	1200	840	0.3	6.5	940	670	0.2	6.5	700	300	0.07	6.5
10	0.5	50	1400	1200	0.3	6.5	1200	840	0.25	6.5	940	670	0.2	6.5	700	300	0.06	6.5
10	1	30	2000	2000	0.6	6	1700	1400	0.5	6	1300	1100	0.4	6	1000	500	0.12	6
10	1	50	2000	2000	0.5	6	1700	1400	0.4	6	1300	1100	0.3	6	1000	500	0.11	6
10	2	30	2900	3900	1.2	4.5	2400	2700	1	4.5	1900	2200	0.7	4.5	1500	980	0.24	4.5
10	2	50	2900	3900	1.1	4.5	2400	2700	0.9	4.5	1900	2200	0.7	4.5	1500	980	0.22	4.5
10	2	70	2400	3300	1	4.5	2000	2300	0.8	4.5	1600	1800	0.6	4.5	1200	830	0.2	4.5
10	2	90	2400	3300	1	4.5	2000	2300	0.8	4.5	1600	1800	0.6	4.5	1200	830	0.2	4.5
11	2	—	2600	3600	1.2	5	2200	2500	1	5	1700	2000	0.7	5	1300	900	0.24	5
12	0.5	36	1200	1100	0.5	8	1000	770	0.4	8	800	620	0.3	8	600	280	0.11	8
12	0.5	60	1200	1100	0.5	8	1000	770	0.4	8	800	620	0.3	8	600	280	0.1	8
12	1	36	1400	1400	0.7	7.5	1200	1000	0.6	7.5	940	780	0.4	7.5	700	350	0.14	7.5
12	1	60	1400	1400	0.6	7.5	1200	1000	0.5	7.5	940	780	0.4	7.5	700	350	0.13	7.5
12	2	36	2400	3600	1.8	6	2000	2500	1.4	6	1600	2000	1.1	6	1200	900	0.4	6
12	2	60	2400	3600	1.6	6	2000	2500	1.3	6	1600	2000	1	6	1200	900	0.3	6
12	2	84	2000	3000	1.4	6	1700	2100	1.1	6	1300	1700	0.8	6	1000	750	0.3	6
12	2	108	2000	3000	0.9	6	1700	2100	0.7	6	1300	1700	0.5	6	1000	750	0.2	6
12	3	36	2400	3600	1.8	4.5	2000	2500	1.4	4.5	1600	2000	1.1	4.5	1200	900	0.4	4.5
12	3	60	2400	3600	1.6	4.5	2000	2500	1.3	4.5	1600	2000	1	4.5	1200	900	0.3	4.5
13	3	—	2200	3600	1.8	5	1800	2500	1.4	5	1500	2000	1.1	5	1100	900	0.4	5
16	0.5	42	900	900	0.5	11	750	630	0.4	11	600	500	0.3	11	450	230	0.1	11
16	2	42	1300	1500	0.9	9	1100	1100	0.7	9	870	840	0.5	9	650	380	0.2	9
16	3	42	1800	3000	1.8	7.5	1500	2100	1.4	7.5	1200	1700	0.9	7.5	900	750	0.4	7.5
16	3	80	1800	3000	1.6	7.5	1500	2100	1.3	7.5	1200	1700	0.8	7.5	900	750	0.3	7.5
16	3	120	1500	2500	1.4	7.5	1200	1800	1.1	7.5	1000	1400	0.7	7.5	750	630	0.3	7.5

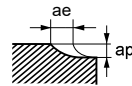

- Note 1) If the depth of cut is shallow, the revolution and feed rate can be increased.
- Note 2) Air blow or oil mist is recommended for good chip evacuation.
- Note 3) For profile machining such as moulds, machining conditions may differ considerably depending on the workpiece geometry, machining methods and depth of cut. Reduce the feed rate especially when machining the corner sections of a workpiece.
- Note 4) The irregular helix flute end mill has a larger effect on controlling vibration when compared to standard end mills. However, if the rigidity of the machine or the workpiece installation is poor, vibration or abnormal sound can occur. In this case, please reduce the revolution and feed rate proportionately, or set a lower depth of cut.

VFHVRB

Corner radius, Short cut length, Irregular helix, 4 flute



CARBIDE

Carbon Steel, Alloy Steel, Cast Iron (<30HRC)	Tool Steel, Pre-Hardened Steel, Hardened Steel (≤45HRC)	Hardened Steel (≤55HRC)	Hardened Steel (>55HRC)	Austenitic Stainless Steel	Titanium Alloy, Heat Resistant Alloy	Copper Alloy	Aluminium Alloy
---	---	-------------------------	-------------------------	----------------------------	--------------------------------------	--------------	-----------------

Taper neck type

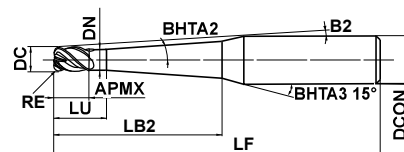

Effective length for inclined angle

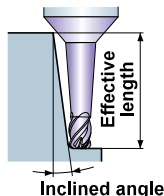

	DC ≤ 10	DC > 10			
	±0.007	±0.01			
	DC ≤ 12				
	0 - 0.02				
	DCON = 6	8 ≤ DCON ≤ 10	12 ≤ DCON ≤ 16		
	0 - 0.008	0 - 0.009	0 - 0.011		

● IMPACT MIRACLE corner radius end mill for high feed and efficient machining.

(mm)

Order Number	DC	RE	BHTA2	APMX	LU	LB2	DN	B2	LF	DCON	Flutes	Stock	Effective length for inclined angle				
													0.5°	1°	2°	3°	
													VFHVRBD010R02N006T09	1	0.2	0.9°	1
VFHVRBD010R02N010T09	1	0.2	0.9°	1	2.5	10	0.94	7.5°	60	6	4	●	—	10.6	11.4	12.3	
VFHVRBD010R02N015T09	1	0.2	0.9°	1	2.5	15	0.94	6.1°	60	6	4	●	—	15.6	16.8	18.1	
VFHVRBD010R02N020T09	1	0.2	0.9°	1	2.5	20	0.94	5.1°	80	6	4	●	—	20.6	22.1	23.9	
VFHVRBD010R02N025T09	1	0.2	0.9°	1	2.5	25	0.94	4.4°	80	6	4	●	—	25.6	27.5	29.7	
VFHVRBD010R02N030T09	1	0.2	0.9°	1	2.5	30	0.94	3.8°	80	6	4	●	—	30.6	32.9	35.5	
VFHVRBD010R02N035T09	1	0.2	0.9°	1	2.5	35	0.94	3.4°	90	6	4	●	—	35.6	38.3	41.3	
VFHVRBD010R02N040T09	1	0.2	0.9°	1	2.5	40	0.94	3.1°	90	6	4	●	—	40.6	43.6	47.2	
VFHVRBD010R02N045T09	1	0.2	0.9°	1	2.5	45	0.94	2.8°	90	6	4	●	—	45.6	49	*	
VFHVRBD010R02N050T09	1	0.2	0.9°	1	2.5	50	0.94	2.6°	90	6	4	●	—	50.6	54.4	*	
VFHVRBD015R03N010T09	1.5	0.3	0.9°	1.5	3	10	1.44	7.1°	60	6	4	●	—	10.6	11.4	12.3	
VFHVRBD015R03N015T09	1.5	0.3	0.9°	1.5	3	15	1.44	5.7°	60	6	4	●	—	15.6	16.8	18.1	
VFHVRBD015R03N020T09	1.5	0.3	0.9°	1.5	3	20	1.44	4.7°	80	6	4	●	—	20.6	22.2	23.9	
VFHVRBD015R03N030T09	1.5	0.3	0.9°	1.5	3	30	1.44	3.5°	80	6	4	●	—	30.6	32.9	35.6	
VFHVRBD015R03N040T09	1.5	0.3	0.9°	1.5	3	40	1.44	2.8°	90	6	4	●	—	40.6	43.7	*	
VFHVRBD015R03N050T09	1.5	0.3	0.9°	1.5	3	50	1.44	2.4°	90	6	4	●	—	50.6	54.4	*	
VFHVRBD020R05N015T04	2	0.5	0.4°	2	4	15	1.9	5.2°	60	6	4	●	●	15.6	16.2	17.4	18.7
VFHVRBD020R05N020T04	2	0.5	0.4°	2	4	20	1.9	4.3°	80	6	4	●	●	20.6	21.3	22.9	24.7
VFHVRBD020R05N025T04	2	0.5	0.4°	2	4	25	1.9	3.6°	80	6	4	●	●	25.6	26.5	28.5	30.8
VFHVRBD020R05N030T04	2	0.5	0.4°	2	4	30	1.9	3.2°	80	6	4	●	●	30.6	31.7	34	36.8
VFHVRBD020R05N035T04	2	0.5	0.4°	2	4	35	1.9	2.8°	80	6	4	●	●	35.6	36.9	39.6	*
VFHVRBD020R05N040T04	2	0.5	0.4°	2	4	40	1.9	2.5°	80	6	4	●	●	40.6	42	45.2	*
VFHVRBD020R05N020T09	2	0.5	0.9°	2	4	20	1.9	4.4°	80	6	4	●	—	20.8	22.3	24.1	
VFHVRBD020R05N025T09	2	0.5	0.9°	2	4	25	1.9	3.7°	90	6	4	●	—	25.8	27.7	29.9	
VFHVRBD020R05N030T09	2	0.5	0.9°	2	4	30	1.9	3.2°	90	6	4	●	—	30.8	33	35.7	
VFHVRBD020R05N035T09	2	0.5	0.9°	2	4	35	1.9	2.9°	90	6	4	●	—	35.8	38.4	*	
VFHVRBD020R05N040T09	2	0.5	0.9°	2	4	40	1.9	2.6°	90	6	4	●	—	40.8	43.8	*	
VFHVRBD020R05N045T09	2	0.5	0.9°	2	4	45	1.9	2.3°	90	6	4	●	—	45.8	49.2	*	
VFHVRBD020R05N050T09	2	0.5	0.9°	2	4	50	1.9	2.2°	100	6	4	●	—	50.8	54.5	*	
VFHVRBD020R05N055T09	2	0.5	0.9°	2	4	55	1.9	2°	100	6	4	●	—	55.8	59.9	*	
VFHVRBD020R05N060T09	2	0.5	0.9°	2	4	60	1.9	1.8°	100	6	4	●	—	60.8	*	*	
VFHVRBD030R08N020T09	3	0.8	0.9°	3	6	20	2.9	3.6°	80	6	4	●	—	20.9	22.4	24.1	
VFHVRBD030R08N025T09	3	0.8	0.9°	3	6	25	2.9	3°	80	6	4	●	—	25.9	27.8	30	
VFHVRBD030R08N030T09	3	0.8	0.9°	3	6	30	2.9	2.6°	80	6	4	●	—	30.9	33.1	*	

* No interference

● : Inventory maintained.

SOLID END MILLS

SQUARE

BALL

RADIUS

TAPER

BARREL

ROUGHING

IMPACT MIRACLE END MILLS

VFHVRB

Corner radius, Short cut length, Irregular helix, 4 flute

(mm)

Order Number	DC	RE	BHTA2	APMX	LU	LB2	DN	B2	LF	DCON	Flutes	Stock	Effective length for inclined angle			
													0.5°	1°	2°	3°
VFHVRBD030R08N040T09	3	0.8	0.9°	3	6	40	2.9	2°	90	6	4	●	—	40.9	43.9	*
VFHVRBD030R08N050T09	3	0.8	0.9°	3	6	50	2.9	1.7°	90	6	4	●	—	50.9	*	*
VFHVRBD030R08N060T09	3	0.8	0.9°	3	6	60	2.9	1.4°	100	6	4	●	—	60.9	*	*
VFHVRBD040R10N025T04	4	1	0.4°	4	7	25	3.9	2.1°	80	6	4	●	25.7	26.6	28.5	*
VFHVRBD040R10N030T04	4	1	0.4°	4	7	30	3.9	1.8°	80	6	4	●	30.7	31.8	*	*
VFHVRBD040R10N035T04	4	1	0.4°	4	7	35	3.9	1.6°	80	6	4	★	35.7	36.9	*	*
VFHVRBD040R10N040T04	4	1	0.4°	4	7	40	3.9	1.4°	80	6	4	●	40.7	42.1	*	*
VFHVRBD040R10N045T04	4	1	0.4°	4	7	45	3.9	1.3°	90	6	4	★	45.7	47.3	*	*
VFHVRBD040R10N050T04	4	1	0.4°	4	7	50	3.9	1.2°	90	6	4	★	50.7	52.5	*	*
VFHVRBD040R10N025T09	4	1	0.9°	4	7	25	3.9	2.2°	90	6	4	●	—	25.9	27.8	*
VFHVRBD040R10N030T09	4	1	0.9°	4	7	30	3.9	1.9°	90	6	4	●	—	30.9	*	*
VFHVRBD040R10N040T09	4	1	0.9°	4	7	40	3.9	1.4°	100	6	4	●	—	40.9	*	*
VFHVRBD040R10N050T09	4	1	0.9°	4	7	50	3.9	1.2°	100	6	4	●	—	50.9	*	*
VFHVRBD040R10N060T09	4	1	0.9°	4	7	60	3.9	1°	100	6	4	●	—	60.9	*	*
VFHVRBD060R15N040T09	6	1.5	0.9°	9	12	40	5.85	1.4°	110	8	4	●	—	41.4	*	*
VFHVRBD060R15N050T09	6	1.5	0.9°	9	12	50	5.85	1.2°	110	8	4	●	—	51.4	*	*
VFHVRBD060R15N060T09	6	1.5	0.9°	9	12	60	5.85	1°	110	8	4	★	—	61.4	*	*
VFHVRBD060R15N070T09	6	1.5	0.9°	9	12	70	5.85	0.9°	110	8	4	●	—	*	*	*
VFHVRBD080R20N060T09	8	2	0.9°	12	15	60	7.85	1°	150	10	4	●	—	61.5	*	*
VFHVRBD080R20N080T09	8	2	0.9°	12	15	80	7.85	0.8°	150	10	4	●	—	*	*	*
VFHVRBD100R20N080T09	10	2	0.9°	15	18	80	9.7	2°	130	16	4	●	—	82	88	*
VFHVRBD100R20N120T09	10	2	0.9°	15	18	120	9.7	1.4°	180	16	4	★	—	122	*	*
VFHVRBD120R20N080T09	12	2	0.9°	18	28	80	11.7	1.4°	130	16	4	●	—	82.2	*	*
VFHVRBD120R20N120T09	12	2	0.9°	18	28	120	11.7	1°	180	16	4	★	—	122.2	*	*

* No interference

- CARBIDE
-
- SOLID END MILLS
- SQUARE
- BALL
- RADIUS
- TAPER
- BARREL
- ROUGHING

● : Inventory maintained. ★ : Inventory maintained in Japan.

RECOMMENDED CUTTING CONDITIONS

■ High depth of cut conditions

Work material				P								H							
				Carbon steel, Cast iron, Alloy steel (—30HRC)				Alloy steel, Tool steel, Pre-hardened steel				Hardened steel (45—55HRC)				Hardened steel (55—62HRC)			
				Cf53, GG25				X40CrMoV51				X40CrMoV51				X210Cr12			
Dia. DC (mm)	Corner R RE (mm)	Taper angle one side BHTA2°	Neck length LB2 (mm)	Revolution (min ⁻¹)	Feed rate (mm/min)	Depth of cut ap (mm)	Depth of cut ae (mm)	Revolution (min ⁻¹)	Feed rate (mm/min)	Depth of cut ap (mm)	Depth of cut ae (mm)	Revolution (min ⁻¹)	Feed rate (mm/min)	Depth of cut ap (mm)	Depth of cut ae (mm)	Revolution (min ⁻¹)	Feed rate (mm/min)	Depth of cut ap (mm)	Depth of cut ae (mm)
1	0.2	0.9°	6	40000	6500	0.03	0.45	33000	4600	0.022	0.45	27000	3700	0.018	0.45	20000	1600	0.01	0.45
1	0.2	0.9°	10	24000	2700	0.015	0.45	20000	1900	0.01	0.45	16000	1500	0.008	0.45	12000	700	0.006	0.45
1	0.2	0.9°	15	16000	1200	0.013	0.45	14000	700	0.008	0.45	12000	500	0.007	0.45	10000	400	0.003	0.45
1	0.2	0.9°	20	14000	1000	0.01	0.45	12000	600	0.006	0.45	10000	400	0.005	0.45	9000	300	0.002	0.45
1	0.2	0.9°	25	9500	610	0.008	0.45	8000	440	0.005	0.45	6000	320	0.004	0.45	4800	160	0.002	0.45
1	0.2	0.9°	30	4900	320	0.007	0.45	4100	220	0.004	0.45	3000	160	0.003	0.45	2500	80	0.002	0.45
1	0.2	0.9°	35	4000	260	0.006	0.45	3400	190	0.003	0.45	3000	160	0.003	0.45	2000	70	0.001	0.45
1	0.2	0.9°	40	3500	180	0.005	0.45	2900	130	0.003	0.45	2000	90	0.003	0.45	1700	50	0.001	0.45
1	0.2	0.9°	45	2900	150	0.004	0.45	2400	100	0.002	0.45	2000	90	0.002	0.45	1400	40	0.001	0.45
1	0.2	0.9°	50	2900	110	0.003	0.45	2400	80	0.002	0.45	2000	60	0.002	0.45	1400	30	0.001	0.45
1.5	0.3	0.9°	10	27000	5700	0.05	0.65	22000	4000	0.035	0.65	18000	3000	0.03	0.65	14000	1400	0.014	0.65
1.5	0.3	0.9°	15	22000	3200	0.03	0.65	18000	2300	0.025	0.65	15000	1700	0.018	0.65	11000	1000	0.009	0.65
1.5	0.3	0.9°	20	16000	1400	0.02	0.65	14000	1200	0.016	0.65	13000	1000	0.012	0.65	9000	700	0.007	0.65
1.5	0.3	0.9°	30	13000	900	0.01	0.65	11000	700	0.008	0.65	10000	600	0.006	0.65	7500	400	0.004	0.65
1.5	0.3	0.9°	40	4500	230	0.008	0.65	3700	160	0.007	0.65	3000	120	0.005	0.65	2300	70	0.003	0.65
1.5	0.3	0.9°	50	3700	190	0.007	0.65	3000	130	0.006	0.65	3000	120	0.004	0.65	1900	60	0.002	0.65
2	0.5	0.4°	15	20000	7000	0.05	0.75	17000	5000	0.04	0.75	13000	3200	0.03	0.75	10000	1800	0.016	0.75
2	0.5	0.4°	20	20000	3600	0.04	0.75	17000	2600	0.03	0.75	13000	1800	0.025	0.75	10000	900	0.012	0.75
2	0.5	0.4°	25	16000	1800	0.03	0.75	14000	1400	0.025	0.75	12000	1100	0.02	0.75	9000	720	0.01	0.75
2	0.5	0.4°	30	16000	1400	0.025	0.75	14000	1200	0.02	0.75	12000	900	0.016	0.75	9000	650	0.008	0.75
2	0.5	0.4°	35	13000	1100	0.02	0.75	11000	800	0.018	0.75	10000	700	0.014	0.75	7000	500	0.007	0.75
2	0.5	0.4°	40	13000	1000	0.02	0.75	11000	700	0.015	0.75	10000	600	0.012	0.75	7000	400	0.006	0.75
2	0.5	0.9°	20	20000	3600	0.04	0.75	17000	2600	0.03	0.75	13000	1800	0.025	0.75	10000	900	0.012	0.75
2	0.5	0.9°	25	16000	1800	0.03	0.75	14000	1400	0.025	0.75	12000	1100	0.02	0.75	9000	720	0.01	0.75
2	0.5	0.9°	30	16000	1400	0.025	0.75	14000	1200	0.02	0.75	12000	900	0.016	0.75	9000	650	0.008	0.75
2	0.5	0.9°	35	13000	1100	0.02	0.75	11000	800	0.018	0.75	10000	700	0.014	0.75	7000	500	0.007	0.75
2	0.5	0.9°	40	13000	1000	0.02	0.75	11000	700	0.015	0.75	10000	600	0.012	0.75	7000	400	0.006	0.75
2	0.5	0.9°	45	8000	500	0.016	0.75	6800	360	0.012	0.75	5200	250	0.01	0.75	4000	120	0.005	0.75
2	0.5	0.9°	50	8000	500	0.016	0.75	6800	360	0.012	0.75	5200	250	0.01	0.75	4000	120	0.005	0.75
2	0.5	0.9°	55	4100	230	0.012	0.75	3500	170	0.009	0.75	2700	120	0.008	0.75	2000	60	0.004	0.75
2	0.5	0.9°	60	4100	230	0.012	0.75	3500	170	0.009	0.75	2700	120	0.008	0.75	2000	60	0.004	0.75
3	0.8	0.9°	20	13000	7200	0.19	1	11000	5100	0.15	1	8700	4000	0.11	1	6500	1800	0.06	1
3	0.8	0.9°	25	13000	7200	0.19	1	11000	5100	0.15	1	8700	4000	0.11	1	6500	1800	0.06	1
3	0.8	0.9°	30	13000	5700	0.12	1	11000	4000	0.09	1	8700	3000	0.07	1	6500	1400	0.04	1
3	0.8	0.9°	40	11000	3600	0.08	1	9100	2600	0.06	1	7400	2000	0.05	1	5500	1000	0.025	1
3	0.8	0.9°	50	8000	2600	0.07	1	6600	1800	0.05	1	5800	1500	0.04	1	4600	800	0.02	1
3	0.8	0.9°	60	7800	2480	0.06	1	6600	1740	0.05	1	5000	1250	0.04	1	3900	610	0.02	1
Depth of cut																			

Note 1) If the depth of cut is shallow, the revolution and feed rate can be increased.

Note 2) Air blow or oil mist is recommended for good chip evacuation.

Note 3) For profile machining such as moulds, machining conditions may differ considerably depending on the workpiece geometry, machining methods and depth of cut. Reduce the feed rate especially when machining the corner sections of a workpiece.

Note 4) The irregular helix flute end mill has a larger effect on controlling vibration when compared to standard end mills. However, if the rigidity of the machine or the workpiece installation is poor, vibration or abnormal sound can occur. In this case, please reduce the revolution and feed rate proportionately, or set a lower depth of cut.

IMPACT MIRACLE END MILLS

VFHVRB

Corner radius, Short cut length, Irregular helix, 4 flute

CARBIDE

SOLID END MILLS

SQUARE

BALL

RADIUS

TAPER

BARREL

ROUGHING

Work material				P								H							
				Carbon steel, Cast iron, Alloy steel (—30HRC) Cf53, GG25				Alloy steel, Tool steel, Pre-hardened steel X40CrMoV51				Hardened steel (45—55HRC) X40CrMoV51				Hardened steel (55—62HRC) X210Cr12			
Dia. DC (mm)	Corner R RE (mm)	Taper angle one side BHTA2	Neck length LB2 (mm)	Revolution (min ⁻¹)	Feed rate (mm/min)	Depth of cut ap (mm)	Depth of cut ae (mm)	Revolution (min ⁻¹)	Feed rate (mm/min)	Depth of cut ap (mm)	Depth of cut ae (mm)	Revolution (min ⁻¹)	Feed rate (mm/min)	Depth of cut ap (mm)	Depth of cut ae (mm)	Revolution (min ⁻¹)	Feed rate (mm/min)	Depth of cut ap (mm)	Depth of cut ae (mm)
4	1	0.4°	25	10000	9900	0.24	1.5	8300	7000	0.19	1.5	6700	5600	0.14	1.5	5000	2500	0.07	1.5
4	1	0.4°	30	10000	9900	0.24	1.5	8300	7000	0.19	1.5	6700	5600	0.14	1.5	5000	2500	0.07	1.5
4	1	0.4°	35	10000	9900	0.15	1.5	8300	7000	0.12	1.5	6700	5600	0.09	1.5	5000	2500	0.04	1.5
4	1	0.4°	40	10000	9900	0.15	1.5	8300	7000	0.12	1.5	6700	5600	0.09	1.5	5000	2500	0.04	1.5
4	1	0.4°	45	10000	9900	0.15	1.5	8300	7000	0.12	1.5	6700	5600	0.09	1.5	5000	2500	0.04	1.5
4	1	0.4°	50	8100	6300	0.14	1.5	6700	4420	0.11	1.5	5400	3500	0.08	1.5	4000	1600	0.04	1.5
4	1	0.9°	25	10000	9900	0.24	1.5	8300	7000	0.19	1.5	6700	5600	0.14	1.5	5000	2500	0.07	1.5
4	1	0.9°	30	10000	9900	0.15	1.5	8300	7000	0.12	1.5	6700	5600	0.09	1.5	5000	2500	0.04	1.5
4	1	0.9°	40	10000	9900	0.15	1.5	8300	7000	0.12	1.5	6700	5600	0.09	1.5	5000	2500	0.04	1.5
4	1	0.9°	50	8100	6300	0.14	1.5	6700	4420	0.11	1.5	5400	3500	0.08	1.5	4000	1600	0.04	1.5
4	1	0.9°	60	8100	6300	0.11	1.5	6700	4420	0.08	1.5	5400	3500	0.06	1.5	4000	1600	0.03	1.5
6	1.5	0.9°	40	6600	11000	0.4	2	5500	7600	0.32	2	4500	6100	0.24	2	3300	2700	0.12	2
6	1.5	0.9°	50	6600	11000	0.4	2	5500	7600	0.32	2	4500	6100	0.24	2	3300	2700	0.12	2
6	1.5	0.9°	60	6600	11000	0.25	2	5500	7600	0.2	2	4500	6100	0.15	2	3300	2700	0.08	2
6	1.5	0.9°	70	5400	8700	0.23	2	4400	6200	0.18	2	3600	5000	0.14	2	2700	2200	0.07	2
8	2	0.9°	60	5000	11000	0.48	3	4200	7600	0.37	3	3300	6100	0.29	3	2500	2700	0.14	3
8	2	0.9°	80	5000	11000	0.3	3	4200	7600	0.23	3	3300	6100	0.18	3	2500	2700	0.09	3
10	2	0.9°	80	4000	11000	0.48	4.5	3300	7600	0.37	4.5	2700	6100	0.29	4.5	2000	2700	0.14	4.5
10	2	0.9°	120	3200	8700	0.27	4.5	2700	6200	0.21	4.5	2100	5000	0.16	4.5	1600	2200	0.08	4.5
12	2	0.9°	80	3300	10000	0.72	6	2700	7100	0.56	6	2200	5600	0.36	6	1700	2500	0.18	6
12	2	0.9°	120	3300	10000	0.45	6	2700	7100	0.35	6	2200	5600	0.23	6	1700	2500	0.12	6

Depth of cut

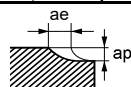

Note 1) If the depth of cut is shallow, the revolution and feed rate can be increased.

Note 2) Air blow or oil mist is recommended for good chip evacuation.

Note 3) For profile machining such as moulds, machining conditions may differ considerably depending on the workpiece geometry, machining methods and depth of cut. Reduce the feed rate especially when machining the corner sections of a workpiece.

Note 4) The irregular helix flute end mill has a larger effect on controlling vibration when compared to standard end mills. However, if the rigidity of the machine or the workpiece installation is poor, vibration or abnormal sound can occur. In this case, please reduce the revolution and feed rate proportionately, or set a lower depth of cut.

IMPACT MIRACLE REVOLUTION END MILLS

VFR2SSB

Ball nose, Short cut length, Short shank, 2 flute



CARBIDE

Carbon Steel, Alloy Steel, Cast Iron (<30HRC)	Tool Steel, Pre-Hardened Steel, Hardened Steel (≤45HRC)	Hardened Steel (≤55HRC)	Hardened Steel (>55HRC)	Austenitic Stainless Steel	Titanium Alloy, Heat Resistant Alloy	Copper Alloy	Aluminium Alloy
---	---	-------------------------	-------------------------	----------------------------	--------------------------------------	--------------	-----------------

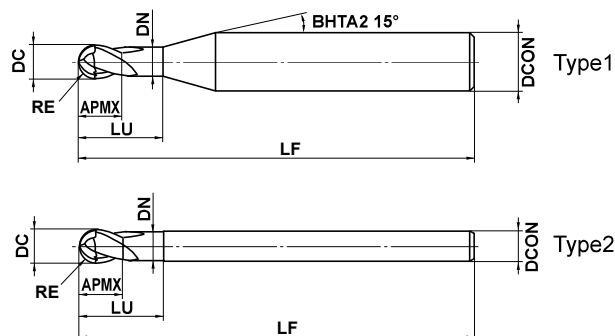

	RE ≤ 6				
	±0.005				
	4 ≤ DCON ≤ 6	8 ≤ DCON ≤ 10	DCON = 12		
	0 - 0.005	0 - 0.006	0 - 0.008		

● Optimisation of the cutting edge curve, helix angle and rake angle have improved the edge strength of the whole cutting edge.

(mm)

Order Number	RE	DC	APMX	LU	DN	LF	DCON	Flutes	Stock	Type
VFR2SSBR0050S04	0.5	1	1	2	0.94	40	4	2	●	1
VFR2SSBR0050	0.5	1	1	2	0.94	40	6	2	●	1
VFR2SSBR0075S04	0.75	1.5	1.5	3	1.44	40	4	2	●	1
VFR2SSBR0075	0.75	1.5	1.5	3	1.44	40	6	2	●	1
VFR2SSBR0100	1	2	2	4	1.9	45	6	2	●	1
VFR2SSBR0150	1.5	3	3	6	2.9	45	6	2	●	1
VFR2SSBR0200	2	4	4	8	3.9	45	6	2	●	1
VFR2SSBR0250	2.5	5	5	10	4.9	50	6	2	●	1
VFR2SSBR0300	3	6	6	12	5.85	50	6	2	●	2
VFR2SSBR0400	4	8	8	14	7.85	60	8	2	●	2
VFR2SSBR0500	5	10	10	18	9.7	70	10	2	●	2
VFR2SSBR0600	6	12	12	22	11.7	75	12	2	●	2

SOLID END MILLS

SQUARE

BALL

RADIUS

TAPER

BARREL

ROUGHING

● : Inventory maintained.

IMPACT MIRACLE REVOLUTION END MILLS

VFR2SB

Ball nose, Short cut length, 2 flute

CARBIDE



RE<0.3

RE≥0.3

Carbon Steel, Alloy Steel, Cast Iron (<30HRC)	Tool Steel, Pre-Hardened Steel, Hardened Steel (≤45HRC)	Hardened Steel (≤55HRC)	Hardened Steel (>55HRC)	Austenitic Stainless Steel	Titanium Alloy, Heat Resistant Alloy	Copper Alloy	Aluminium Alloy
	○	◎	◎				

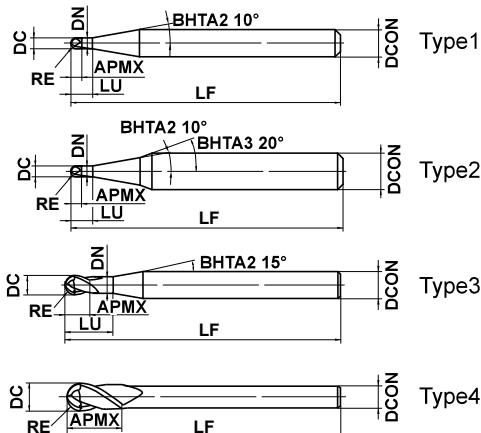

RE≤6	RE>6			
±0.005	±0.010			
DCON=3	4≤DCON≤6	8≤DCON≤10	DCON=12,16	DCON=20
0 - 0.004	0 - 0.005	0 - 0.006	0 - 0.008	0 - 0.009

● For roughing and high precision pre-finishing and finishing of high hardness materials.

(mm)

Order Number	RE	DC	APMX	LU	DN	LF	DCON	Flutes	Stock	Type
VFR2SBR0010	0.1	0.2	0.2	0.4	0.17	45	4	2	●	1
VFR2SBR0010S06	0.1	0.2	0.2	0.4	0.17	50	6	2	●	2
VFR2SBR0015	0.15	0.3	0.3	0.6	0.27	45	4	2	●	1
VFR2SBR0015S06	0.15	0.3	0.3	0.6	0.27	50	6	2	●	2
VFR2SBR0020	0.2	0.4	0.4	0.8	0.36	45	4	2	●	1
VFR2SBR0020S06	0.2	0.4	0.4	0.8	0.36	50	6	2	●	2
VFR2SBR0030	0.3	0.6	0.6	1.2	0.56	45	4	2	●	3
VFR2SBR0030S06	0.3	0.6	0.6	1.2	0.56	50	6	2	●	3
VFR2SBR0040	0.4	0.8	0.8	1.6	0.76	45	4	2	●	3
VFR2SBR0040S06	0.4	0.8	0.8	1.6	0.76	50	6	2	●	3
VFR2SBR0050	0.5	1	1	2	0.94	45	4	2	●	3
VFR2SBR0050S06	0.5	1	1	2	0.94	50	6	2	●	3
VFR2SBR0060	0.6	1.2	1.2	2.4	1.14	45	4	2	●	3
VFR2SBR0060S06	0.6	1.2	1.2	2.4	1.14	50	6	2	●	3
VFR2SBR0070	0.7	1.4	1.4	2.8	1.34	45	4	2	●	3
VFR2SBR0070S06	0.7	1.4	1.4	2.8	1.34	50	6	2	●	3
VFR2SBR0075	0.75	1.5	1.5	3	1.44	45	4	2	●	3
VFR2SBR0075S06	0.75	1.5	1.5	3	1.44	50	6	2	●	3
VFR2SBR0080	0.8	1.6	1.6	3.2	1.54	45	4	2	●	3
VFR2SBR0080S06	0.8	1.6	1.6	3.2	1.54	50	6	2	●	3
VFR2SBR0090	0.9	1.8	1.8	3.6	1.74	45	4	2	●	3
VFR2SBR0090S06	0.9	1.8	1.8	3.6	1.74	50	6	2	●	3
VFR2SBR0100	1	2	2	4	1.9	50	4	2	●	3
VFR2SBR0100S06	1	2	2	4	1.9	60	6	2	●	3
VFR2SBR0125S06	1.25	2.5	2.5	5	2.4	60	6	2	●	3
VFR2SBR0150S03	1.5	3	3	—	—	60	3	2	●	4
VFR2SBR0150	1.5	3	3	6	2.9	70	6	2	●	3
VFR2SBR0200S04	2	4	4	—	—	60	4	2	●	4
VFR2SBR0200	2	4	4	8	3.9	70	6	2	●	3
VFR2SBR0250	2.5	5	5	10	4.9	80	6	2	●	3
VFR2SBR0300	3	6	12	—	—	80	6	2	●	4
VFR2SBR0400	4	8	14	—	—	90	8	2	●	4
VFR2SBR0500	5	10	18	—	—	100	10	2	●	4
VFR2SBR0600	6	12	22	—	—	110	12	2	●	4

● : Inventory maintained.

(mm)

Order Number	RE	DC	APMX	LU	DN	LF	DCON	Flutes	Stock	Type
VFR2SBR0800	8	16	30	—	—	140	16	2	●	4
VFR2SBR1000	10	20	38	—	—	160	20	2	●	4

VFR2SSB

Ball nose, Short cut length, Short shank, 2 flute

VFR2SB

Ball nose, Short cut length, 2 flute

RECOMMENDED CUTTING CONDITIONS

Work material	H																	
	Hardened steel (45—55HRC)						Hardened steel (55—62HRC)						Hardened steel (62—70HRC)					
	X40CrMo951						X210Cr12						070M55, 1.3343 (W6Mo5Cr492)					
RE (mm)	$\alpha \leq 15^\circ$		$\alpha > 15^\circ$		Depth of cut ap (mm)	Depth of cut ae (mm)	$\alpha \leq 15^\circ$		$\alpha > 15^\circ$		Depth of cut ap (mm)	Depth of cut ae (mm)	$\alpha \leq 15^\circ$		$\alpha > 15^\circ$		Depth of cut ap (mm)	Depth of cut ae (mm)
	Revolution (min ⁻¹)	Feed rate (mm/min)	Revolution (min ⁻¹)	Feed rate (mm/min)			Revolution (min ⁻¹)	Feed rate (mm/min)	Revolution (min ⁻¹)	Feed rate (mm/min)			Revolution (min ⁻¹)	Feed rate (mm/min)	Revolution (min ⁻¹)	Feed rate (mm/min)		
R 0.1	40000	320	40000	240	0.003	0.02	40000	320	40000	160	0.003	0.02	40000	320	40000	160	0.002	0.02
R 0.15	40000	640	40000	560	0.01	0.03	40000	640	40000	400	0.007	0.03	40000	640	40000	400	0.005	0.03
R 0.2	40000	1600	40000	1200	0.02	0.04	40000	1400	40000	1000	0.015	0.04	40000	1200	40000	1000	0.01	0.04
R 0.3	40000	3200	40000	1600	0.03	0.06	40000	2800	40000	1200	0.025	0.06	40000	2000	40000	1200	0.02	0.06
R 0.4	40000	6400	40000	2400	0.05	0.08	40000	4000	40000	1600	0.04	0.08	40000	2800	40000	1600	0.03	0.08
R 0.5	40000	8000	40000	3200	0.06	0.10	40000	5600	40000	2400	0.05	0.10	40000	3600	32000	1300	0.04	0.10
R 0.75	40000	9600	40000	4000	0.09	0.15	40000	7200	32000	2500	0.075	0.15	32000	4500	21000	1200	0.05	0.15
R 1	40000	9600	39000	4700	0.11	0.20	40000	8000	24000	2400	0.1	0.20	24000	3800	16000	1000	0.07	0.20
R 1.25	40000	10400	32000	4500	0.12	0.25	37000	8100	19000	2300	0.11	0.25	19000	3400	13000	1000	0.08	0.25
R 1.5	40000	12000	27000	4300	0.13	0.30	32000	7700	16000	2200	0.12	0.30	16000	3200	11000	880	0.09	0.30
R 2	32000	10880	20000	3600	0.15	0.40	24000	6200	12000	1900	0.13	0.40	12000	2400	8000	800	0.1	0.40
R 2.5	25000	9000	16000	2900	0.20	0.50	19000	5300	9600	1700	0.15	0.50	9600	2100	6000	600	0.1	0.50
R 3	21000	8400	13000	2600	0.25	0.60	16000	4800	8000	1600	0.2	0.60	8000	1700	5000	600	0.11	0.60
R 4	16000	6400	10000	2000	0.30	0.80	12000	3600	6000	1200	0.2	0.80	6000	1400	4000	480	0.11	0.80
R 5	13000	5200	8000	1700	0.50	1.00	10000	3200	4800	960	0.2	1.00	4800	1100	3000	420	0.12	1.00
R 6	9000	3600	6000	1300	0.50	1.20	7000	2200	3600	720	0.3	1.20	3600	860	2200	310	0.12	1.20
R 8	6000	2400	4000	1000	0.50	1.60	5000	1600	2500	500	0.3	1.60	2500	650	1500	240	0.15	1.60
R10	4500	1800	3000	780	0.50	2.00	4000	1300	1800	360	0.3	2.00	1800	470	1000	160	0.15	2.00

Depth of cut

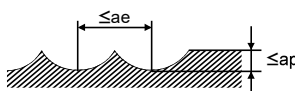

Note 1) α is the inclination angle of the machined surface.

Note 2) If the depth of cut is smaller, the revolution and the feed rate can be increased. Please reduce the feed rate when the surface finish is important.

Note 3) If the rigidity of the machine or the work materials installation is very low, or chattering and noise are generated, reduce the revolution and the feed rate proportionately.

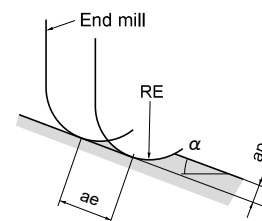

ae:Pick Feed

SOLID END MILLS

SQUARE

BALL

RADIUS

TAPER

BARREL

ROUGHING

IMPACT MIRACLE REVOLUTION END MILLS

VFR2SBF

Ball nose, For mirror finishing, Short cut length, 2 flute



Carbon Steel, Alloy Steel, Cast Iron (<30HRC)	Tool Steel, Pre-Hardened Steel, Hardened Steel (≤45HRC)	Hardened Steel (≤55HRC)	Hardened Steel (>55HRC)	Austenitic Stainless Steel	Titanium Alloy, Heat Resistant Alloy	Copper Alloy	Aluminium Alloy
	○	◎	◎				

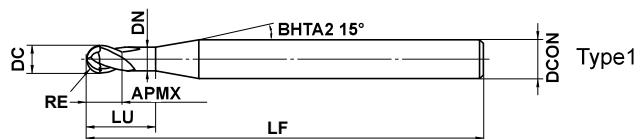

SOLID END MILLS

	RE ≤ 3			
	±0.010			
	4 ≤ DCON ≤ 6			
	0 - 0.005			

● For finishing of high hardness materials with excellent surface finishes.

(mm)

Order Number	RE	DC	APMX	LU	DN	LF	DCON	Flutes	Stock	Type
VFR2SBFR0050	0.5	1	1	2	0.94	45	4	2	●	1
VFR2SBFR0075	0.75	1.5	1.5	3	1.44	45	4	2	●	1
VFR2SBFR0100	1	2	2	4	1.9	60	6	2	●	1
VFR2SBFR0125	1.25	2.5	2.5	5	2.4	60	6	2	●	1
VFR2SBFR0150	1.5	3	3	6	2.9	70	6	2	●	1
VFR2SBFR0200	2	4	4	8	3.9	70	6	2	●	1
VFR2SBFR0250	2.5	5	5	10	4.9	80	6	2	●	1
VFR2SBFR0300	3	6	12	—	—	80	6	2	●	2

SQUARE

BALL

RADIUS

TAPER

BARREL

ROUGHING

● : Inventory maintained.

RECOMMENDED CUTTING CONDITIONS

Work material	P		H				H					
	Pre-hardened steel (35–45HRC) Carbon steel, alloy steel (180–280HB) Alloy steel (≤350HB) Hardened steel (40–62HRC) X40CrMoV51, X210Cr12, X40CrMoV51		Hardened steel (62–70HRC) 070M55, 1.3343 (6Mo5Cr4V2)				$\alpha \leq 15^\circ$		$\alpha > 15^\circ$		Depth of cut a_p (mm)	Depth of cut a_e (mm)
	RE (mm)	Revolution (min ⁻¹)	Feed rate (mm/min)	Revolution (min ⁻¹)	Feed rate (mm/min)	Depth of cut a_p (mm)	Depth of cut a_e (mm)	Revolution (min ⁻¹)	Feed rate (mm/min)	Revolution (min ⁻¹)	Feed rate (mm/min)	Depth of cut a_p (mm)
R 0.5	40000	800	40000	800	0.007	0.007	40000	560	40000	560	0.005	0.005
R 0.75	40000	800	40000	800	0.009	0.009	40000	560	40000	560	0.007	0.007
R 1.0	35000	1050	35000	1050	0.011	0.011	35000	700	35000	700	0.009	0.009
R 1.25	35000	1050	35000	1050	0.013	0.013	35000	700	35000	700	0.011	0.011
R 1.5	35000	1050	35000	1050	0.015	0.015	35000	700	35000	700	0.013	0.013
R 2.0	25000	1000	25000	1000	0.017	0.017	25000	750	25000	750	0.015	0.015
R 2.5	25000	1000	25000	1000	0.020	0.020	25000	750	25000	750	0.015	0.015
R 3.0	25000	1000	25000	1000	0.020	0.020	25000	750	25000	750	0.015	0.015

Depth of cut

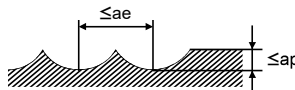

Note 1) This tool is recommended for finish machining only.

Note 2) Air blow or oil mist is recommended for good chip evacuation.

Note 3) Note the following points when using the tools.

- Avoid using equipment abruptly without proper preparation. After sufficient warming up of equipment, ensure that there will be no changes to the depth of cut such as due to elongation of the main axis during machining.
- If the tools are used immediately after rough machining of a surface, large uneven areas (cusp heights) will cause deflection of the tools and waviness of the machined surface. Therefore, it is recommended to add a medium finish machining process which uses the same value of a_e as indicated in the table above.

Note 4) α is the inclination angle of the machined surface.

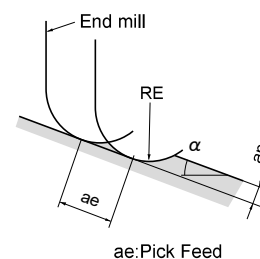

IMPACT MIRACLE REVOLUTIONEND MILLS

VFR2XLB NEW

Ball nose, Long neck, 2 flute



Carbon Steel, Alloy Steel, Cast Iron (<30HRC)	Tool Steel, Pre-Hardened Steel, Hardened Steel (≤45HRC)	Hardened Steel (≤55HRC)	Hardened Steel (>55HRC)	Austenitic Stainless Steel	Titanium Alloy, Heat Resistant Alloy	Copper Alloy	Aluminium Alloy
---	---	-------------------------	-------------------------	----------------------------	--------------------------------------	--------------	-----------------

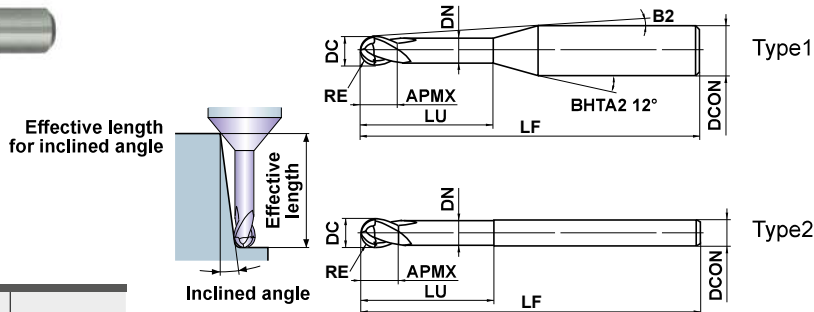

	RE ≤ 3				
	±0.005				
	4 ≤ DCON ≤ 6				
	0 - 0.005				

● Precise machining of vertical walls is possible due to a back taper and a strong, seamless ball nose cutting edge geometry.

(mm)

Order Number	RE	DC	APMX	LU	DN	B2	LF	DCON	Flutes	Stock	Type	Effective length for inclined angle			
												0.5°	1°	2°	3°
												VFR2XLB R0030N020	0.3	0.6	0.45
VFR2XLB R0030N020S06	0.3	0.6	0.45	2	0.57	10.6°	50	6	2	●	1	2.1	2.2	2.4	2.6
VFR2XLB R0030N030	0.3	0.6	0.45	3	0.57	9°	50	4	2	●	1	3.1	3.3	3.6	4
VFR2XLB R0030N030S06	0.3	0.6	0.45	3	0.57	9.9°	50	6	2	●	1	3.1	3.3	3.6	4
VFR2XLB R0030N040	0.3	0.6	0.45	4	0.57	8.2°	50	4	2	●	1	4.2	4.4	4.8	5.3
VFR2XLB R0030N050	0.3	0.6	0.45	5	0.57	7.6°	50	4	2	●	1	5.2	5.5	6	6.6
VFR2XLB R0030N060	0.3	0.6	0.45	6	0.57	7.1°	50	4	2	●	1	6.3	6.6	7.2	7.9
VFR2XLB R0040N030	0.4	0.8	0.6	3	0.77	8.9°	50	4	2	●	1	3.1	3.3	3.6	3.9
VFR2XLB R0040N040	0.4	0.8	0.6	4	0.77	8.2°	50	4	2	●	1	4.2	4.4	4.8	5.2
VFR2XLB R0040N060	0.4	0.8	0.6	6	0.77	6.9°	50	4	2	●	1	6.3	6.5	7.2	7.9
VFR2XLB R0040N080	0.4	0.8	0.6	8	0.77	6°	50	4	2	●	1	8.4	8.7	9.5	10.6
VFR2XLB R0050N030	0.5	1	0.75	3	0.96	8.7°	50	4	2	●	1	3.2	3.4	3.7	4.1
VFR2XLB R0050N030S06	0.5	1	0.75	3	0.96	9.8°	50	6	2	●	1	3.2	3.4	3.7	4.1
VFR2XLB R0050N040	0.5	1	0.75	4	0.96	7.9°	50	4	2	●	1	4.3	4.5	4.9	5.4
VFR2XLB R0050N040S06	0.5	1	0.75	4	0.96	9.2°	50	6	2	●	1	4.3	4.5	4.9	5.4
VFR2XLB R0050N060	0.5	1	0.75	6	0.96	6.7°	50	4	2	●	1	6.3	6.5	7.2	7.9
VFR2XLB R0050N060S06	0.5	1	0.75	6	0.96	8.2°	50	6	2	●	1	6.3	6.5	7.2	7.9
VFR2XLB R0050N080	0.5	1	0.75	8	0.96	5.8°	50	4	2	●	1	8.5	8.9	9.7	10.7
VFR2XLB R0050N100	0.5	1	0.75	10	0.96	5.1°	50	4	2	●	1	10.6	11.1	12.1	13.4
VFR2XLB R0050N120	0.5	1	0.75	12	0.96	4.6°	50	4	2	●	1	12.7	13.2	14.5	16
VFR2XLB R0075N060	0.75	1.5	1.1	6	1.44	6.3°	50	4	2	●	1	6.3	6.6	7.2	7.9
VFR2XLB R0075N060S06	0.75	1.5	1.1	6	1.44	8°	50	6	2	●	1	6.3	6.6	7.2	7.9
VFR2XLB R0075N080	0.75	1.5	1.1	8	1.44	5.4°	50	4	2	●	1	8.4	8.8	9.6	10.6
VFR2XLB R0075N080S06	0.75	1.5	1.1	8	1.44	7.2°	50	6	2	●	1	8.4	8.8	9.6	10.6
VFR2XLB R0075N100	0.75	1.5	1.1	10	1.44	4.7°	50	4	2	●	1	10.5	11	12	13.2
VFR2XLB R0075N120	0.75	1.5	1.1	12	1.44	4.2°	50	4	2	●	1	12.6	13.1	14.4	15.9
VFR2XLB R0075N140	0.75	1.5	1.1	14	1.44	3.8°	50	4	2	●	1	14.7	15.3	16.8	18.5
VFR2XLB R0075N160	0.75	1.5	1.1	16	1.44	3.4°	60	4	2	●	1	16.8	17.5	19.2	21.2
VFR2XLB R0100N060	1	2	1.5	6	1.94	5.8°	50	4	2	●	1	6.3	6.6	7.1	7.8
VFR2XLB R0100N060S06	1	2	1.5	6	1.94	7.8°	50	6	2	●	1	6.3	6.6	7.1	7.8
VFR2XLB R0100N080	1	2	1.5	8	1.94	4.8°	50	4	2	●	1	8.4	8.8	9.5	10.5
VFR2XLB R0100N080S06	1	2	1.5	8	1.94	6.9°	50	6	2	●	1	8.4	8.8	9.5	10.5

● : Inventory maintained.

(mm)

Order Number	RE	DC	APMX	LU	DN	B2	LF	DCON	Flutes	Stock	Type	Effective length for inclined angle			
												0.5°	1°	2°	3°
												VFR2XLBR0100N100	1	2	1.5
VFR2XLBR0100N100S06	1	2	1.5	10	1.94	6.2°	50	6	2	●	1	10.5	10.9	11.9	13.1
VFR2XLBR0100N120	1	2	1.5	12	1.94	3.6°	50	4	2	●	1	12.6	13.1	14.3	15.8
VFR2XLBR0100N120S06	1	2	1.5	12	1.94	5.6°	50	6	2	●	1	12.6	13.1	14.3	15.8
VFR2XLBR0100N160	1	2	1.5	16	1.94	2.9°	60	4	2	●	1	16.8	17.5	19.1	*
VFR2XLBR0100N160S06	1	2	1.5	16	1.94	4.7°	60	6	2	●	1	16.8	17.5	19.1	21.1
VFR2XLBR0100N200	1	2	1.5	20	1.94	2.4°	60	4	2	●	1	20.9	21.8	23.9	*
VFR2XLBR0100N200S06	1	2	1.5	20	1.94	4°	60	6	2	●	1	20.9	21.8	23.9	26.4
VFR2XLBR0125N100	1.25	2.5	1.9	10	2.4	3.5°	60	4	2	●	1	10.4	10.8	11.8	12.9
VFR2XLBR0125N150	1.25	2.5	1.9	15	2.4	2.5°	60	4	2	●	1	15.6	16.3	17.8	*
VFR2XLBR0150N100	1.5	3	2.3	10	2.9	5.5°	60	6	2	●	1	10.4	10.8	11.7	12.9
VFR2XLBR0150N120	1.5	3	2.3	12	2.9	4.9°	60	6	2	●	1	12.5	13	14.1	15.5
VFR2XLBR0150N160	1.5	3	2.3	16	2.9	4°	70	6	2	●	1	16.7	17.3	18.9	20.8
VFR2XLBR0150N200	1.5	3	2.3	20	2.9	3.4°	70	6	2	●	1	20.8	21.7	23.7	26.1
VFR2XLBR0150N250	1.5	3	2.3	25	2.9	2.8°	70	6	2	●	1	26.1	27.2	29.7	*
VFR2XLBR0150N300	1.5	3	2.3	30	2.9	2.5°	70	6	2	●	1	31.3	32.6	35.7	*
VFR2XLBR0200N100	2	4	3	10	3.9	4.5°	70	6	2	●	1	10.4	10.8	11.6	12.7
VFR2XLBR0200N120	2	4	3	12	3.9	3.9°	70	6	2	●	1	12.5	12.9	14	15.4
VFR2XLBR0200N160	2	4	3	16	3.9	3.1°	70	6	2	●	1	16.6	17.3	18.8	20.7
VFR2XLBR0200N200	2	4	3	20	3.9	2.6°	70	6	2	●	1	20.8	21.7	23.6	*
VFR2XLBR0200N250	2	4	3	25	3.9	2.1°	70	6	2	●	1	26	27.1	29.6	*
VFR2XLBR0200N300	2	4	3	30	3.9	1.8°	70	6	2	●	1	31.2	32.6	*	*
VFR2XLBR0250N200	2.5	5	3.8	20	4.9	1.5°	70	6	2	●	1	20.8	21.6	*	*
VFR2XLBR0250N250	2.5	5	3.8	25	4.9	1.2°	70	6	2	●	1	26	27.1	*	*
VFR2XLBR0300N180	3	6	6	18	5.85	—	80	6	2	●	2	*	*	*	*
VFR2XLBR0300N300	3	6	6	30	5.85	—	80	6	2	●	2	*	*	*	*

* No interference

SOLID END MILLS

SQUARE

BALL

RADIUS

TAPER

BARREL

ROUGHING

IMPACT MIRACLE REVOLUTION END MILLS

VFR2XLB NEW

Ball nose, Long neck, 2 flute

CARBIDE

SOLID END MILLS

SQUARE

BALL

RADIUS

TAPER

BARREL

ROUGHING

RECOMMENDED CUTTING CONDITIONS

Work material		H							
		Hardened Steels (45—55HRC)				Hardened Steels (55—70HRC)			
RE (mm)	Neck length LU (mm)	Revolution (min ⁻¹)	Feed rate (mm/min)	Depth of cut ap (mm)	Width of Cut ae (mm)	Revolution (min ⁻¹)	Feed Rate (mm/min)	Depth of cut ap (mm)	Width of Cut ae (mm)
0.3	2	40000	2800	0.03	0.03	40000	2800	0.02	0.03
0.3	3	40000	2800	0.03	0.03	40000	2800	0.02	0.03
0.3	4	35000	2000	0.02	0.03	35000	2000	0.015	0.03
0.3	5	30000	1000	0.01	0.03	30000	1000	0.007	0.03
0.3	6	30000	800	0.008	0.03	30000	800	0.005	0.03
0.4	3	40000	3000	0.04	0.04	40000	3000	0.03	0.04
0.4	4	40000	3000	0.02	0.04	40000	3000	0.015	0.04
0.4	6	30000	1600	0.02	0.04	30000	1600	0.01	0.04
0.4	8	25000	1000	0.01	0.04	25000	1000	0.007	0.04
0.5	3	40000	4000	0.05	0.05	40000	4000	0.04	0.05
0.5	4	40000	4000	0.05	0.05	40000	4000	0.04	0.05
0.5	6	35000	2000	0.03	0.05	35000	2000	0.02	0.05
0.5	8	30000	1600	0.02	0.05	30000	1600	0.01	0.05
0.5	10	20000	1000	0.01	0.05	20000	1000	0.01	0.05
0.5	12	20000	1000	0.01	0.05	20000	800	0.008	0.05
0.75	6	40000	5000	0.07	0.075	40000	4000	0.06	0.075
0.75	8	40000	5000	0.07	0.075	40000	3500	0.06	0.075
0.75	10	40000	4500	0.06	0.075	40000	2400	0.06	0.075
0.75	12	32000	3400	0.04	0.075	32000	2000	0.04	0.075
0.75	14	16000	1500	0.04	0.075	16000	1200	0.03	0.075
0.75	16	13000	1200	0.03	0.075	13000	1200	0.02	0.075
1	6	40000	6000	0.1	0.1	40000	3400	0.1	0.1
1	8	40000	5000	0.1	0.1	40000	3000	0.1	0.1
1	10	40000	5000	0.08	0.1	40000	3000	0.07	0.1
1	12	40000	5000	0.08	0.1	40000	2600	0.05	0.1
1	16	32000	3500	0.05	0.1	32000	1700	0.03	0.1
1	20	10000	1000	0.04	0.1	10000	1000	0.03	0.1
1.25	10	36000	5000	0.12	0.25	36000	2600	0.11	0.25
1.25	15	36000	4600	0.08	0.25	36000	2000	0.075	0.25
1.5	10	32000	5100	0.15	0.3	32000	2200	0.15	0.3
1.5	12	32000	5100	0.13	0.3	32000	2200	0.13	0.3
1.5	16	32000	4500	0.1	0.3	32000	1800	0.1	0.3
1.5	20	27000	3800	0.1	0.3	27000	1600	0.06	0.3
1.5	25	21000	2700	0.08	0.3	21000	1200	0.06	0.3
1.5	30	9000	1000	0.08	0.3	9000	700	0.05	0.3
2	10	24000	4800	0.2	0.4	24000	2200	0.2	0.4
2	12	24000	4800	0.2	0.4	24000	2200	0.2	0.4
2	16	24000	3800	0.15	0.4	24000	1500	0.15	0.4
2	20	24000	3800	0.15	0.4	24000	1500	0.15	0.4
2	25	24000	3800	0.15	0.4	24000	1100	0.1	0.4
2	30	24000	3000	0.1	0.4	24000	1100	0.08	0.4
2.5	20	19000	3400	0.2	0.5	19000	1400	0.2	0.5
2.5	25	19000	3400	0.2	0.5	19000	1400	0.2	0.5
3	18	16000	3500	0.25	0.6	16000	1000	0.2	0.6
3	30	16000	3500	0.2	0.6	16000	1000	0.2	0.6

Depth of cut

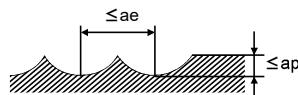

Note 1) When the inclination angle of machined surface is large, or machining with large cutting load such as in corners, reduce the revolution and feed rate.

Note 2) If the depth of cut is shallow, the revolution and feed rate can be increased.

Note 3) Cutting conditions may differ considerably due to the tool overhang, depth of cut and machine tool condition. Please use the table above as a reference starting point.

VFRPSRB NEW

Corner radius end mill, Short cut length, High precision, 4 flute



CARBIDE

Carbon Steel, Alloy Steel, Cast Iron (<30HRC)	Tool Steel, Pre-Hardened Steel, Hardened Steel (≤45HRC)	Hardened Steel (≤55HRC)	Hardened Steel (>55HRC)	Austenitic Stainless Steel	Titanium Alloy, Heat Resistant Alloy	Copper Alloy	Aluminium Alloy
	○	◎	◎				



Effective length for inclined angle

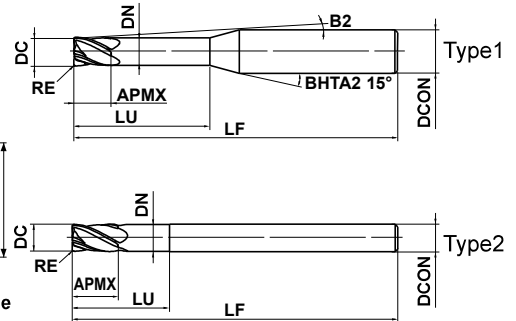
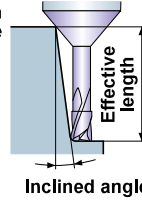

	0.5 ≤ DC ≤ 6	6 < DC ≤ 12			
	±0.005	±0.007			
	0.5 ≤ DC ≤ 6	6 < DC ≤ 12			
	⁰ / _{-0.01}	⁰ / _{-0.015}			
	DCON=6	8 ≤ DCON ≤ 10	DCON=12		
	⁰ / _{-0.005}	⁰ / _{-0.006}	⁰ / _{-0.008}		

● Seamless corner radius geometry. DC ≥ 1.5

● The wiper edge and strong back taper achieve high-precision machining. 1.5 ≤ DC ≤ 5

(mm)

Order Number	DC	RE	APMX	LU	DN	B2	LF	DCON	Flutes	Stock	Type	Effective length for inclined angle			
												0.5°	1°	2°	3°
												VFRPSRBD0050R005N020	0.5	0.05	0.5
VFRPSRBD0050R010N020	0.5	0.1	0.5	2	0.47	12.7	50	6	4	●	1	2.1	2.2	2.3	2.5
VFRPSRBD0060R005N020	0.6	0.05	0.6	2	0.57	12.5	50	6	4	●	1	2.1	2.2	2.4	2.6
VFRPSRBD0060R010N020	0.6	0.1	0.6	2	0.57	12.5	50	6	4	●	1	2.1	2.2	2.3	2.6
VFRPSRBD0060R010N040	0.6	0.1	0.6	4	0.57	10.8	50	6	4	●	1	4.2	4.4	4.7	5.1
VFRPSRBD0060R020N020	0.6	0.2	0.6	2	0.57	12.6	50	6	4	●	1	2.1	2.2	2.2	2.6
VFRPSRBD0080R005N040	0.8	0.05	0.8	4	0.77	10.7	50	6	4	●	1	4.2	4.4	4.7	5.1
VFRPSRBD0080R010N040	0.8	0.1	0.8	4	0.77	10.7	50	6	4	●	1	4.2	4.4	4.7	5.1
VFRPSRBD0080R020N040	0.8	0.2	0.8	4	0.77	10.8	50	6	4	●	1	4.2	4.4	4.7	5.1
VFRPSRBD0080R030N040	0.8	0.3	0.8	4	0.77	10.8	50	6	4	●	1	4.2	4.4	4.7	5
VFRPSRBD0100R005N040	1	0.05	1	4	0.96	10.4	50	6	4	●	1	4.3	4.5	4.9	5.4
VFRPSRBD0100R010N040	1	0.1	1	4	0.96	10.4	50	6	4	●	1	4.3	4.5	4.9	5.4
VFRPSRBD0100R010N060	1	0.1	1	6	0.96	9.1	50	6	4	●	1	6.4	6.7	7.3	7.9
VFRPSRBD0100R020N040	1	0.2	1	4	0.96	10.5	50	6	4	●	1	4.3	4.5	4.7	5.3
VFRPSRBD0100R020N060	1	0.2	1	6	0.96	9.2	50	6	4	●	1	6.4	6.7	7.3	7.8
VFRPSRBD0100R030N040	1	0.3	1	4	0.96	10.5	50	6	4	●	1	4.3	4.5	4.6	5.3
VFRPSRBD0100R040N040	1	0.4	1	4	0.96	10.6	50	6	4	●	1	4.3	4.5	4.5	5.3
VFRPSRBD0150R010N040	1.5	0.1	1.5	4	1.42	10.2	50	6	4	●	1	4.2	4.4	4.8	5.2
VFRPSRBD0150R010N060	1.5	0.1	1.5	6	1.42	8.8	50	6	4	●	1	6.3	6.6	7.1	7.7
VFRPSRBD0150R010N100	1.5	0.1	1.5	10	1.42	6.9	50	6	4	●	1	10.5	10.9	11.7	12.7
VFRPSRBD0150R020N040	1.5	0.2	1.5	4	1.42	10.2	50	6	4	●	1	4.2	4.4	4.6	5.2
VFRPSRBD0150R020N060	1.5	0.2	1.5	6	1.42	8.8	50	6	4	●	1	6.3	6.6	7.1	7.7
VFRPSRBD0150R020N100	1.5	0.2	1.5	10	1.42	7	50	6	4	●	1	10.5	10.9	11.7	12.6
VFRPSRBD0150R030N040	1.5	0.3	1.5	4	1.42	10.3	50	6	4	●	1	4.2	4.4	4.5	5.2
VFRPSRBD0150R030N060	1.5	0.3	1.5	6	1.42	8.9	50	6	4	●	1	6.3	6.6	7.1	7.6
VFRPSRBD0150R030N100	1.5	0.3	1.5	10	1.42	7	50	6	4	●	1	10.5	10.9	11.7	12.6
VFRPSRBD0150R050N040	1.5	0.5	1.5	4	1.42	10.5	50	6	4	●	1	4.2	4.4	4.3	5.1
VFRPSRBD0150R050N060	1.5	0.5	1.5	6	1.42	9	50	6	4	●	1	6.3	6.6	7.1	7.6
VFRPSRBD0150R050N100	1.5	0.5	1.5	10	1.42	7.1	50	6	4	●	1	10.5	10.9	11.7	12.6
VFRPSRBD0200R010N060	2	0.1	2	6	1.9	8.4	50	6	4	●	1	6.3	6.6	7.1	7.6
VFRPSRBD0200R010N100	2	0.1	2	10	1.9	6.5	50	6	4	●	1	10.5	10.9	11.7	12.6
VFRPSRBD0200R010N150	2	0.1	2	15	1.9	5.1	50	6	4	●	1	15.7	16.2	17.4	18.8
VFRPSRBD0200R020N060	2	0.2	2	6	1.9	8.4	50	6	4	●	1	6.3	6.6	7.1	7.6
VFRPSRBD0200R020N100	2	0.2	2	10	1.9	6.5	50	6	4	●	1	10.5	10.9	11.7	12.6

● : Inventory maintained.

SOLID END MILLS

SQUARE

BALL

RADIUS

TAPER

BARREL

ROUGHING

IMPACT MIRACLE REVOLUTION END MILLS

VFRPSRB NEW

Corner radius end mill, Short cut length, High precision, 4 flute

(mm)

	Order Number	DC	RE	APMX	LU	DN	B2	LF	DCON	Flutes	Stock	Type	Effective length for inclined angle			
													0.5°	1°	2°	3°
SOLID END MILLS	VFRPSRBD0200R020N150	2	0.2	2	15	1.9	5.1	50	6	4	●	1	15.7	16.2	17.4	18.8
	VFRPSRBD0200R030N060	2	0.3	2	6	1.9	8.5	50	6	4	●	1	6.3	6.6	7	7.6
	VFRPSRBD0200R030N100	2	0.3	2	10	1.9	6.6	50	6	4	●	1	10.5	10.8	11.6	12.6
	VFRPSRBD0200R030N150	2	0.3	2	15	1.9	5.1	50	6	4	●	1	15.7	16.2	17.4	18.8
	VFRPSRBD0200R030N200	2	0.3	2	20	1.9	4.2	60	6	4	●	1	20.8	21.5	23.1	25
	VFRPSRBD0200R050N060	2	0.5	2	6	1.9	8.6	50	6	4	●	1	6.3	6.5	7	7.5
	VFRPSRBD0200R050N100	2	0.5	2	10	1.9	6.6	50	6	4	●	1	10.5	10.8	11.6	12.5
	VFRPSRBD0200R050N150	2	0.5	2	15	1.9	5.2	50	6	4	●	1	15.6	16.2	17.4	18.7
	VFRPSRBD0200R050N200	2	0.5	2	20	1.9	4.2	60	6	4	●	1	20.8	21.5	23.1	24.9
	VFRPSRBD0250R030N080	2.5	0.3	2.5	8	2.35	6.9	50	6	4	●	1	8.3	8.6	9.2	10
	VFRPSRBD0250R030N150	2.5	0.3	2.5	15	2.35	4.7	50	6	4	●	1	15.6	16.1	17.3	18.7
	VFRPSRBD0250R050N080	2.5	0.5	2.5	8	2.35	7	50	6	4	●	1	8.3	8.6	9.2	9.9
	VFRPSRBD0250R050N150	2.5	0.5	2.5	15	2.35	4.7	50	6	4	●	1	15.6	16.1	17.3	18.6
	VFRPSRBD0250R100N080	2.5	1	2.5	8	2.35	7.3	50	6	4	●	1	8.3	8.6	9.1	9.8
	VFRPSRBD0300R010N100	3	0.1	3	10	2.85	5.5	60	6	4	●	1	10.4	10.8	11.6	12.5
	VFRPSRBD0300R010N150	3	0.1	3	15	2.85	4.2	60	6	4	●	1	15.6	16.1	17.3	18.7
VFRPSRBD0300R020N100	3	0.2	3	10	2.85	5.5	60	6	4	●	1	10.4	10.8	11.6	12.5	
VFRPSRBD0300R020N150	3	0.2	3	15	2.85	4.2	60	6	4	●	1	15.6	16.1	17.3	18.7	
VFRPSRBD0300R020N200	3	0.2	3	20	2.85	3.4	60	6	4	●	1	20.7	21.5	23.1	24.9	
VFRPSRBD0300R030N100	3	0.3	3	10	2.85	5.6	60	6	4	●	1	10.4	10.8	11.5	12.5	
VFRPSRBD0300R030N150	3	0.3	3	15	2.85	4.2	60	6	4	●	1	15.6	16.1	17.3	18.7	
VFRPSRBD0300R030N200	3	0.3	3	20	2.85	3.4	60	6	4	●	1	20.7	21.5	23	24.9	
VFRPSRBD0300R050N100	3	0.5	3	10	2.85	5.6	60	6	4	●	1	10.4	10.7	11.5	12.4	
VFRPSRBD0300R050N150	3	0.5	3	15	2.85	4.2	60	6	4	●	1	15.6	16.1	17.3	18.6	
VFRPSRBD0300R050N200	3	0.5	3	20	2.85	3.4	60	6	4	●	1	20.7	21.4	23	24.8	
VFRPSRBD0300R100N100	3	1	3	10	2.85	5.8	60	6	4	●	1	10.4	10.7	11.4	12.3	
VFRPSRBD0300R100N150	3	1	3	15	2.85	4.3	60	6	4	●	1	15.5	16.1	17.2	18.5	
VFRPSRBD0300R100N200	3	1	3	20	2.85	3.5	60	6	4	●	1	20.7	21.4	22.9	24.7	
VFRPSRBD0400R010N120	4	0.1	4	12	3.85	3.6	60	6	4	●	1	12.5	12.9	13.9	15	
VFRPSRBD0400R010N200	4	0.1	4	20	3.85	2.4	60	6	4	●	1	20.7	21.5	23.1	*	
VFRPSRBD0400R020N120	4	0.2	4	12	3.85	3.7	60	6	4	●	1	12.5	12.9	13.9	15	
VFRPSRBD0400R020N200	4	0.2	4	20	3.85	2.4	60	6	4	●	1	20.7	21.5	23.1	*	
VFRPSRBD0400R030N120	4	0.3	4	12	3.85	3.7	60	6	4	●	1	12.5	12.9	13.8	15	
VFRPSRBD0400R030N200	4	0.3	4	20	3.85	2.4	60	6	4	●	1	20.7	21.5	23	*	
VFRPSRBD0400R030N300	4	0.3	4	30	3.85	1.7	70	6	4	●	1	31.1	32.2	*	*	
VFRPSRBD0400R050N120	4	0.5	4	12	3.85	3.7	60	6	4	●	1	12.5	12.9	13.8	14.9	
VFRPSRBD0400R050N200	4	0.5	4	20	3.85	2.5	60	6	4	●	1	20.7	21.4	23	*	
VFRPSRBD0400R050N300	4	0.5	4	30	3.85	1.7	70	6	4	●	1	31.1	32.1	*	*	
VFRPSRBD0400R100N120	4	1	4	12	3.85	3.8	60	6	4	●	1	12.4	12.8	13.7	14.8	
VFRPSRBD0400R100N200	4	1	4	20	3.85	2.5	60	6	4	●	1	20.7	21.4	22.9	*	
VFRPSRBD0400R100N300	4	1	4	30	3.85	1.7	70	6	4	●	1	31.1	32.1	*	*	
VFRPSRBD0500R050N150	5	0.5	5	15	4.85	1.7	60	6	4	●	1	15.6	16.1	*	*	
VFRPSRBD0500R100N150	5	1	5	15	4.85	1.8	60	6	4	●	1	15.5	16.1	*	*	
VFRPSRBD0600R010N180	6	0.1	9	18	5.85	—	70	6	4	●	2	*	*	*	*	
VFRPSRBD0600R020N180	6	0.2	9	18	5.85	—	70	6	4	●	2	*	*	*	*	
VFRPSRBD0600R030N180	6	0.3	9	18	5.85	—	70	6	4	●	2	*	*	*	*	
VFRPSRBD0600R050N180	6	0.5	9	18	5.85	—	70	6	4	●	2	*	*	*	*	
VFRPSRBD0600R100N180	6	1	9	18	5.85	—	70	6	4	●	2	*	*	*	*	
VFRPSRBD0600R200N180	6	2	9	18	5.85	—	70	6	4	●	2	*	*	*	*	
VFRPSRBD0800R020N240	8	0.2	12	24	7.85	—	90	8	4	●	2	*	*	*	*	
VFRPSRBD0800R030N240	8	0.3	12	24	7.85	—	90	8	4	●	2	*	*	*	*	
VFRPSRBD0800R050N240	8	0.5	12	24	7.85	—	90	8	4	●	2	*	*	*	*	

* No interference

● : Inventory maintained.

(mm)

Order Number	DC	RE	APMX	LU	DN	B2	LF	DCON	Flutes	Stock	Type	Effective length for inclined angle			
												0.5°	1°	2°	3°
VFRPSRBD0800R100N240	8	1	12	24	7.85	—	90	8	4	●	2	*	*	*	*
VFRPSRBD0800R200N240	8	2	12	24	7.85	—	90	8	4	●	2	*	*	*	*
VFRPSRBD1000R030N300	10	0.3	15	30	9.7	—	100	10	4	●	2	*	*	*	*
VFRPSRBD1000R050N300	10	0.5	15	30	9.7	—	100	10	4	●	2	*	*	*	*
VFRPSRBD1000R100N300	10	1	15	30	9.7	—	100	10	4	●	2	*	*	*	*
VFRPSRBD1000R200N300	10	2	15	30	9.7	—	100	10	4	●	2	*	*	*	*
VFRPSRBD1000R300N300	10	3	15	30	9.7	—	100	10	4	●	2	*	*	*	*
VFRPSRBD1200R050N360	12	0.5	18	36	11.7	—	110	12	4	●	2	*	*	*	*
VFRPSRBD1200R100N360	12	1	18	36	11.7	—	110	12	4	●	2	*	*	*	*
VFRPSRBD1200R200N360	12	2	18	36	11.7	—	110	12	4	●	2	*	*	*	*
VFRPSRBD1200R300N360	12	3	18	36	11.7	—	110	12	4	●	2	*	*	*	*

* No interference

SOLID END MILLS

SQUARE

BALL

RADIUS

TAPER

BARREL

ROUGHING

Work material			H											
			Hardened Steels (45—55HRC)				Hardened Steels (55—65HRC)				Hardened Steels (65—70HRC)			
Dia. DC (mm)	Corner Radius RE (mm)	Usable Length LU (mm)	Revolution (min ⁻¹)	Feed Rate (mm/min)	Depth of Cut ap (mm)	Width of Cut ae (mm)	Revolution (min ⁻¹)	Feed Rate (mm/min)	Depth of Cut ap (mm)	Width of Cut ae (mm)	Revolution (min ⁻¹)	Feed Rate (mm/min)	Depth of Cut ap (mm)	Width of Cut ae (mm)
3	0.1	10	8100	1900	0.025	0.6	6500	1200	0.02	0.55	4100	730	0.015	0.55
3	0.1	15	6500	1600	0.025	0.48	5200	940	0.02	0.44	3200	580	0.015	0.44
3	0.2	10	8100	1900	0.055	0.6	6500	1200	0.04	0.55	4100	730	0.025	0.55
3	0.2	15	6500	1600	0.055	0.48	5200	940	0.04	0.44	3200	580	0.025	0.44
3	0.2	20	6500	1600	0.055	0.48	5200	940	0.04	0.44	3200	580	0.025	0.44
3	0.3	10	9000	2200	0.085	0.6	7200	1300	0.055	0.55	4500	810	0.04	0.55
3	0.3	15	7200	1700	0.085	0.48	5800	1000	0.055	0.44	3600	650	0.04	0.44
3	0.3	20	7200	1700	0.085	0.48	5800	1000	0.055	0.44	3600	650	0.04	0.44
3	0.5	10	9000	2200	0.09	0.6	7200	1300	0.06	0.55	4500	810	0.045	0.55
3	0.5	15	7200	1700	0.09	0.48	5800	1000	0.06	0.44	3600	650	0.045	0.44
3	0.5	20	7200	1700	0.09	0.48	5800	1000	0.06	0.44	3600	650	0.045	0.44
3	1	10	9000	2200	0.15	0.54	7200	1300	0.1	0.5	4500	810	0.07	0.5
3	1	15	7200	1700	0.15	0.43	5800	1000	0.1	0.4	3600	650	0.07	0.4
3	1	20	7200	2000	0.15	0.43	5800	1000	0.1	0.4	3600	650	0.07	0.4
4	0.1	12	6100	1700	0.25	0.8	4900	970	0.02	0.74	3000	610	0.015	0.73
4	0.1	20	4900	1400	0.25	0.6	3900	780	0.02	0.6	2400	490	0.015	0.58
4	0.2	12	6100	1700	0.055	0.8	4900	970	0.04	0.74	3000	610	0.025	0.73
4	0.2	20	4900	1400	0.055	0.6	3900	780	0.04	0.6	2400	490	0.025	0.58
4	0.3	12	6800	1900	0.085	0.8	5400	1100	0.055	0.75	3400	680	0.04	0.73
4	0.3	20	5400	1500	0.085	0.6	4300	870	0.055	0.6	2700	540	0.04	0.58
4	0.3	30	4100	1100	0.065	0.5	3200	650	0.045	0.45	2000	410	0.035	0.44
4	0.5	12	6800	1900	0.09	0.8	5400	1100	0.06	0.75	3400	680	0.045	0.74
4	0.5	20	5400	1500	0.09	0.65	4300	870	0.06	0.6	2700	540	0.045	0.58
4	0.5	30	4100	1100	0.075	0.5	4300	650	0.05	0.45	2000	410	0.035	0.44
4	1	12	6800	1900	0.15	0.7	5400	1100	0.1	0.66	3400	680	0.07	0.66
4	1	20	5400	1500	0.15	0.55	4300	870	0.1	0.53	2700	540	0.07	0.53
4	1	30	4100	1100	0.1	0.4	3200	650	0.075	0.4	2000	410	0.055	0.4
5	0.5	15	6400	1800	0.1	1.3	5100	1000	0.065	1.2	3200	640	0.045	1.1
5	1	15	6400	1800	0.15	1.1	5100	1000	0.1	1	3200	640	0.075	1
6	0.1	18	4800	1500	0.03	1.5	3800	920	0.02	1.4	2400	570	0.015	1.3
6	0.2	18	4800	1500	0.06	1.5	3800	920	0.04	1.4	2400	570	0.03	1.3
6	0.3	18	5300	1700	0.09	1.5	4200	1000	0.06	1.4	2700	640	0.045	1.3
6	0.5	18	5300	1700	0.1	1.5	4200	1000	0.065	1.4	2700	640	0.045	1.3
6	1	18	5300	1700	0.15	1.4	4200	1000	0.1	1.2	2700	640	0.075	1.2
6	2	18	5300	1700	0.3	1.3	4200	1000	0.2	1.1	2700	640	0.15	1.1
8	0.2	24	3600	1100	0.06	2	2900	690	0.04	1.8	1800	430	0.03	1.8
8	0.3	24	4000	1300	0.09	2	3200	760	0.06	1.8	2000	480	0.045	1.8
8	0.5	24	4000	1300	0.095	2	3200	760	0.065	1.8	2000	480	0.045	1.8
8	1	24	4000	1300	0.15	1.8	3200	760	0.1	1.7	2000	480	0.075	1.6
8	2	24	4000	1300	0.3	1.7	3200	760	0.2	1.6	2000	480	0.15	1.5
10	0.3	30	3200	1000	0.09	2.5	2500	610	0.06	2.3	1600	380	0.045	2.3
10	0.5	30	3200	1000	0.095	2.5	2500	610	0.065	2.3	1600	380	0.045	2.3
10	1	30	3200	1000	0.15	2.3	2500	610	0.1	2.1	1600	380	0.075	2
10	2	30	3200	1000	0.3	2.1	2500	610	0.2	2	1600	380	0.15	1.9
10	3	30	3200	1000	0.45	1.9	2500	610	0.3	1.7	1600	380	0.2	1.7
12	0.5	36	2700	950	0.1	3	2100	510	0.065	2.8	1300	320	0.05	2.7
12	1	36	2700	950	0.15	2.7	2100	510	0.1	2.5	1300	320	0.075	2.4
12	2	36	2700	950	0.3	2.6	2100	510	0.2	2.4	1300	320	0.15	2.3
12	3	36	2700	950	0.45	2.3	2100	510	0.3	2.1	1300	320	0.2	2

SOLID END MILLS

SQUARE

BALL

RADIUS

TAPER

BARREL

ROUGHING

Depth of Cut

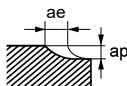

IMPACT MIRACLE END MILLS

VF2WB

Wide ball nose, Medium cut length, 2 flute



Carbon Steel, Alloy Steel, Cast Iron (<30HRC)	Tool Steel, Pre-Hardened Steel, Hardened Steel (≤45HRC)	Hardened Steel (≤55HRC)	Hardened Steel (>55HRC)	Austenitic Stainless Steel	Titanium Alloy, Heat Resistant Alloy	Copper Alloy	Aluminium Alloy
○	○	○		◎	◎		

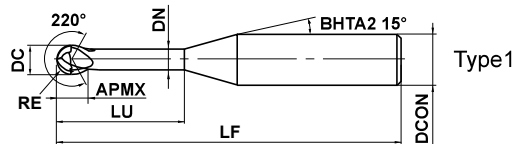

SOLID END MILLS

	1 ≤ RE ≤ 3				
	±0.01				
	DCON=6				
	0 - 0.008				

● Ball nose end mill suitable for machining of undercut and complex geometries using a 5-axis machine.

(mm)

Order Number	RE	DC	APMX	LU	DN	LF	DCON	Flutes	Stock	Type
VF2WBR0100N060	1	2	1.3	6	1.6	60	6	2	●	1
VF2WBR0150N080	1.5	3	2	8	2.4	60	6	2	●	1
VF2WBR0200N100	2	4	2.6	10	3.2	60	6	2	●	1
VF2WBR0300N120	3	6	4	12	4.8	80	6	2	●	1

SQUARE

BALL

RECOMMENDED CUTTING CONDITIONS

Work material	P						M			S			H		
	Revolution (min ⁻¹)	Feed rate (mm/min)	Depth of cut ap (mm)	Revolution (min ⁻¹)	Feed rate (mm/min)	Depth of cut ap (mm)	Revolution (min ⁻¹)	Feed rate (mm/min)	Depth of cut ap (mm)	Revolution (min ⁻¹)	Feed rate (mm/min)	Depth of cut ap (mm)			
Carbon steel, Cast iron, Alloy steel (−30HRC) Cf53, GG25				Alloy steel, Tool steel, Pre-hardened steel X40CrMoV51			Austenitic stainless steel, Titanium alloy X5CrNi1810, X5CrNiMo17-12-2, Ti6Al4V				Hardened steel (45–55HRC) X40CrMoV51				
R1	40000	5000	0.07	40000	5000	0.06	32000	2500	0.05	32000	3000	0.03			
R1.5	32000	5000	0.12	32000	5000	0.11	26000	2500	0.10	26000	3000	0.07			
R2	24000	3800	0.15	24000	3800	0.13	20000	2000	0.12	20000	2800	0.10			
R3	16000	2800	0.20	16000	2800	0.18	13000	1500	0.15	13000	2100	0.12			

Depth of cut

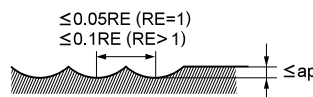

RE:Radius

Note 1) When cutting austenitic stainless steels, the use of water-soluble cutting fluid is effective.

Note 2) If the depth of cut is shallow, the revolution and feed rate can be increased.

● : Inventory maintained.

VF6MHV

End mill, Medium cut length, Irregular helix, 6 flute



CARBIDE

Carbon Steel, Alloy Steel, Cast Iron (<30HRC)	Tool Steel, Pre-Hardened Steel, Hardened Steel (≤45HRC)	Hardened Steel (≤55HRC)	Hardened Steel (>55HRC)	Austenitic Stainless Steel	Titanium Alloy, Heat Resistant Alloy	Copper Alloy	Aluminium Alloy
○	○			◎	◎		

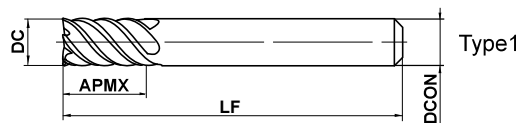

DC ≤ 12	DC > 12			
$\begin{matrix} 0 \\ -0.020 \end{matrix}$	$\begin{matrix} 0 \\ -0.030 \end{matrix}$			
DCON=6	8 ≤ DCON ≤ 10	12 ≤ DCON ≤ 16	DCON=20	
$\begin{matrix} 0 \\ -0.008 \end{matrix}$	$\begin{matrix} 0 \\ -0.009 \end{matrix}$	$\begin{matrix} 0 \\ -0.011 \end{matrix}$	$\begin{matrix} 0 \\ -0.013 \end{matrix}$	



- Newly developed irregular helix 6 flute geometry reduces vibrations and achieves high efficiency machining.
- Suitable for machining of difficult-to-cut materials such as stainless steel, titanium alloy and inconel.

(mm)

Order Number	DC	APMX	LF	DCON	Flutes	Stock	Type
VF6MHVD0600	6	13	50	6	6	●	1
VF6MHVD0800	8	19	60	8	6	●	1
VF6MHVD1000	10	22	70	10	6	●	1
VF6MHVD1200	12	26	75	12	6	●	1
VF6MHVD1600	16	32	90	16	6	●	1
VF6MHVD2000	20	38	100	20	6	●	1

RECOMMENDED CUTTING CONDITIONS

Side milling

Work material	P		M	S	S	
	Alloy steel, Tool steel, Pre-hardened steel	X40CrMoV51	Austenitic stainless steel, Titanium alloy	X5CrNi1810, X5CrNiMo17-12-2, Ti6Al4V	Heat resistant alloys	Inconel718
Dia. DC (mm)	Revolution (min ⁻¹)	Feed rate (mm/min)	Revolution (min ⁻¹)	Feed rate (mm/min)	Revolution (min ⁻¹)	Feed rate (mm/min)
6	10600	2900	8000	2000	2100	320
8	8000	2900	6000	2000	1600	300
10	6400	2700	4800	2000	1300	260
12	5300	2700	4000	2000	1100	230
16	4000	2200	3000	1600	800	180
20	3200	1900	2400	1400	640	150

Depth of cut

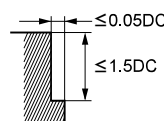
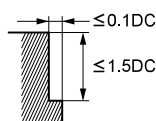

DC: Dia.

Note 1) When cutting austenitic stainless steels, the use of water-soluble cutting fluid is effective.

Note 2) If the depth of cut is shallow, the revolution and feed rate can be increased.

Note 3) The irregular helix flute end mill has a larger effect on controlling vibration when compared to standard end mills. However, if the rigidity of the machine or the workpiece installation is poor, vibration or abnormal sound can occur. In this case, please reduce the revolution and feed rate proportionately, or set a lower depth of cut.

SOLID END MILLS

SQUARE

BALL

RADIUS

TAPER

BARREL

ROUGHING

IMPACT MIRACLE END MILLS

VFMHVCH

End mill. Medium cut length, Irregular helix, 4 flute.
With multiple internal through coolant holes.



Carbon Steel, Alloy Steel, Cast Iron (<30HRC)	Tool Steel, Pre-Hardened Steel, Hardened Steel (≤45HRC)	Hardened Steel (≤55HRC)	Hardened Steel (>55HRC)	Austenitic Stainless Steel	Titanium Alloy, Heat Resistant Alloy	Copper Alloy	Aluminium Alloy
○	○			◎	◎		

CoolStar
END MILLS

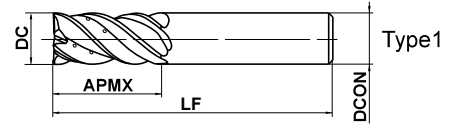

SOLID END MILLS

	16 ≤ DC ≤ 20				
	0 - 0.03				
	DCON=16	DCON=20			
	0 - 0.011	0 - 0.013			

● Vibration control end mill with multiple internal through coolant holes ensures stable machining on difficult-to-cut materials and applications requiring long overhangs.

(mm)

Order Number	DC	APMX	LF	DCON	Flutes	Stock	Type
VFMHVCHD1600	16	35	90	16	4	●	1
VFMHVCHD2000	20	45	110	20	4	●	1

SQUARE

RECOMMENDED CUTTING CONDITIONS

Side milling

Work material	P		M	S	S	
	Revolution (min ⁻¹)	Feed rate (mm/min)	Revolution (min ⁻¹)	Feed rate (mm/min)	Revolution (min ⁻¹)	Feed rate (mm/min)
Alloy steel, Tool steel, Pre-hardened steel (—45HRC) X40CrMoV51			Austenitic stainless steel, Titanium alloy X5CrNi1810, X5CrNiMo17-12-2, Ti6Al4V		Heat resistant alloys Inconel718	
16	3000	1140	2000	560	800	110
20	2400	860	1600	510	600	100

Depth of cut

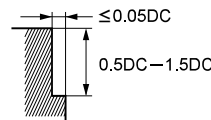
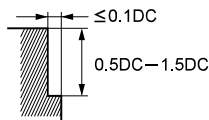

DC: Dia.

Slotting

Work material	P		M	S	S	
	Revolution (min ⁻¹)	Feed rate (mm/min)	Revolution (min ⁻¹)	Feed rate (mm/min)	Revolution (min ⁻¹)	Feed rate (mm/min)
Carbon steel, Cast iron, Alloy steel (—30HRC) Cf53, GG25			Alloy steel, Tool steel, Pre-hardened steel (—45HRC) X40CrMoV51		Austenitic stainless steel, Titanium alloy X5CrNi1810, X5CrNiMo17-12-2, Ti6Al4V	
16	2400	670	1400	380	1400	170
20	1900	610	1100	350	1100	130

Depth of cut

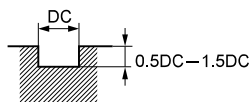

DC: Dia.

Note 1) If the depth of cut is shallow, the revolution and feed rate can be increased.

Note 2) The irregular helix flute end mill has a larger effect on controlling vibration when compared to standard end mills. However, if the rigidity of the machine or the workpiece installation is poor, vibration or abnormal sound can occur. In this case, please reduce the revolution and feed rate proportionately, or set a lower depth of cut.

● : Inventory maintained.

VF8MHVCH

End mill, Medium cut length, Irregular helix, 8 flute.
With multiple internal through coolant holes.



CARBIDE

Carbon Steel, Alloy Steel, Cast Iron (<30HRC)	Tool Steel, Pre-Hardened Steel, Hardened Steel (≤45HRC)	Hardened Steel (≤55HRC)	Hardened Steel (>55HRC)	Austenitic Stainless Steel	Titanium Alloy, Heat Resistant Alloy	Copper Alloy	Aluminium Alloy
○	○			◎	◎		

CoolStar
END MILLS

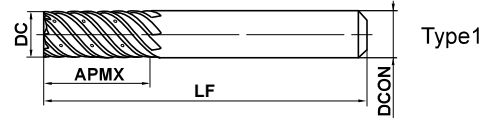

	16 ≤ DC ≤ 20				
	0 - 0.03				
	DCON=16	DCON=20			
	0 - 0.011	0 - 0.013			

- Vibration control end mill with multiple internal through coolant holes ensures stable machining on difficult-to-cut materials and applications requiring long overhangs.

(mm)

Order Number	DC	APMX	LF	DCON	Flutes	Stock	Type
VF8MHVCHD1600	16	32	90	16	8	●	1
VF8MHVCHD2000	20	38	100	20	8	●	1

RECOMMENDED CUTTING CONDITIONS

Side milling

Work material	P		M	S	S	
	Alloy steel, Tool steel, Pre-hardened steel X40CrMoV51		Austenitic stainless steel, Titanium alloy X5CrNi1810, X5CrNiMo17-12-2, Ti6Al4V		Heat resistant alloys Inconel718	
Dia. DC (mm)	Revolution (min ⁻¹)	Feed rate (mm/min)	Revolution (min ⁻¹)	Feed rate (mm/min)	Revolution (min ⁻¹)	Feed rate (mm/min)
16	4000	2400	3000	2100	800	240
20	3200	1900	2400	1900	640	200

Depth of cut

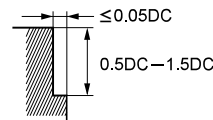
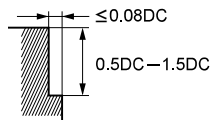

DC: Dia.

Trochoidal slotting

Work material	P		M	S
	Alloy steel, Tool steel, Pre-hardened steel X40CrMoV51		Austenitic stainless steel, Titanium alloy X5CrNi1810, X5CrNiMo17-12-2, Ti6Al4V	
Dia. DC (mm)	Revolution (min ⁻¹)	Feed rate (mm/min)	Revolution (min ⁻¹)	Feed rate (mm/min)
16	4000	1900	3000	1400
20	3200	1500	2400	1200

Depth of cut

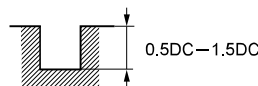
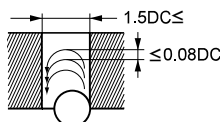

DC: Dia.

Note 1) If the depth of cut is shallow, the revolution and feed rate can be increased.

Note 2) The irregular helix flute end mill has a larger effect on controlling vibration when compared to standard end mills. However, if the rigidity of the machine or the workpiece installation is poor, vibration or abnormal sound can occur. In this case, please reduce the revolution and feed rate proportionately, or set a lower depth of cut.

SOLID END MILLS

SQUARE

BALL

RADIUS

TAPER

BARREL

ROUGHING

IMPACT MIRACLE END MILLS

VF6MHVRB

Corner radius end mill, Medium cut length, Irregular helix, 6 flute



43.5°

45°



CARBIDE

Carbon Steel, Alloy Steel, Cast Iron (<30HRC)	Tool Steel, Pre-Hardened Steel, Hardened Steel (≤45HRC)	Hardened Steel (≤55HRC)	Hardened Steel (>55HRC)	Austenitic Stainless Steel	Titanium Alloy, Heat Resistant Alloy	Copper Alloy	Aluminium Alloy
○	○			◎	◎		

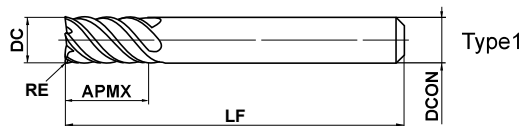

—

SOLID END MILLS

	$0.5 \leq RE \leq 2$				
	± 0.015				
	$DC \leq 12$	$DC > 12$			
	-0.020	-0.030			
	$DCON = 6$	$8 \leq DCON \leq 10$	$12 \leq DCON \leq 16$	$DCON = 20$	
	-0.008	-0.009	-0.011	-0.013	

● Newly developed irregular helix 6 flute geometry reduces vibrations and achieves high efficiency machining.

(mm)

Order Number	DC	RE	APMX	LF	DCON	Flutes	Stock	Type
VF6MHVRBD0600R050	6	0.5	13	50	6	6	●	1
VF6MHVRBD0600R100	6	1	13	50	6	6	●	1
VF6MHVRBD0800R050	8	0.5	19	60	8	6	●	1
VF6MHVRBD0800R100	8	1	19	60	8	6	●	1
VF6MHVRBD1000R050	10	0.5	22	70	10	6	●	1
VF6MHVRBD1000R100	10	1	22	70	10	6	●	1
VF6MHVRBD1200R050	12	0.5	26	75	12	6	●	1
VF6MHVRBD1200R100	12	1	26	75	12	6	●	1
VF6MHVRBD1600R100	16	1	32	90	16	6	●	1
VF6MHVRBD1600R200	16	2	32	90	16	6	●	1
VF6MHVRBD2000R100	20	1	38	100	20	6	●	1
VF6MHVRBD2000R200	20	2	38	100	20	6	●	1

SQUARE

BALL

RADIUS

TAPER

BARREL

ROUGHING

● : Inventory maintained.

RECOMMENDED CUTTING CONDITIONS

■ Side milling

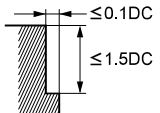
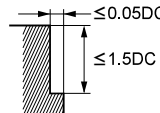
Work material	P		M	S	S	
	Alloy steel, Tool steel, Pre-hardened steel	Austenitic stainless steel, Titanium alloy		Heat resistant alloys		
Dia. DC (mm)	Revolution (min ⁻¹)	Feed rate (mm/min)	Revolution (min ⁻¹)	Feed rate (mm/min)	Revolution (min ⁻¹)	Feed rate (mm/min)
	X40CrMoV51	X5CrNi1810, X5CrNiMo17-12-2, Ti6Al4V		Inconel718		
6	10600	2900	8000	2000	2100	320
8	8000	2900	6000	2000	1600	300
10	6400	2700	4800	2000	1300	260
12	5300	2700	4000	2000	1100	230
16	4000	2200	3000	1600	800	180
20	3200	1900	2400	1400	640	150
Depth of cut						

DC: Dia.

Note 1) When cutting austenitic stainless steels, the use of water-soluble cutting fluid is effective.

Note 2) If the depth of cut is shallow, the revolution and feed rate can be increased.

Note 3) The irregular helix flute end mill has a larger effect on controlling vibration when compared to standard end mills. However, if the rigidity of the machine or the workpiece installation is poor, vibration or abnormal sound can occur. In this case, please reduce the revolution and feed rate proportionately, or set a lower depth of cut.

IMPACT MIRACLE END MILLS

VFMHVRBCH

Corner radius end mill. Medium cut length. Irregular helix, 4 flute. With multiple internal through coolant holes.



Carbon Steel, Alloy Steel, Cast Iron (<30HRC)	Tool Steel, Pre-Hardened Steel, Hardened Steel (≤45HRC)	Hardened Steel (≤55HRC)	Hardened Steel (>55HRC)	Austenitic Stainless Steel	Titanium Alloy, Heat Resistant Alloy	Copper Alloy	Aluminium Alloy
○	○			◎	◎		

CoolStar
END MILLS

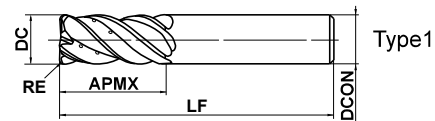

SOLID END MILLS



$1 \leq RE \leq 3$				
± 0.015				



$16 \leq DC \leq 20$				
0 $- 0.03$				



DCON=16	DCON=20			
0 $- 0.011$	0 $- 0.013$			

● Vibration control corner radius end mill with multiple internal through coolant holes ensures stable machining on difficult-to-cut materials and applications requiring long overhangs. (mm)

Order Number	DC	RE	APMX	LF	DCON	Flutes	Stock	Type
VFMHVRBCHD1600R100	16	1	35	90	16	4	●	1
VFMHVRBCHD1600R300	16	3	35	90	16	4	●	1
VFMHVRBCHD2000R100	20	1	45	110	20	4	●	1
VFMHVRBCHD2000R300	20	3	45	110	20	4	●	1

SQUARE

BALL

RADIUS

TAPER

BARREL

ROUGHING

● : Inventory maintained.

RECOMMENDED CUTTING CONDITIONS

■ Side milling

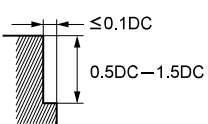
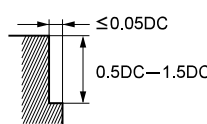
Work material	P		M	S	S	
	Alloy steel, Tool steel, Pre-hardened steel (—45HRC) X40CrMoV51		Austenitic stainless steel, Titanium alloy X5CrNi1810, X5CrNiMo17-12-2, Ti6Al4V		Heat resistant alloys Inconel718	
Dia. DC (mm)	Revolution (min ⁻¹)	Feed rate (mm/min)	Revolution (min ⁻¹)	Feed rate (mm/min)	Revolution (min ⁻¹)	Feed rate (mm/min)
16	3000	1140	2000	560	800	110
20	2400	860	1600	510	600	100
Depth of cut						

DC:Dia.

■ Slotting

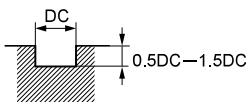
Work material	P		M	S		
	Carbon steel, Cast iron, Alloy steel (—30HRC) Cf53, GG25		Alloy steel, Tool steel, Pre-hardened steel (—45HRC) X40CrMoV51		Austenitic stainless steel, Titanium alloy X5CrNi1810, X5CrNiMo17-12-2, Ti6Al4V	
Dia. DC (mm)	Revolution (min ⁻¹)	Feed rate (mm/min)	Revolution (min ⁻¹)	Feed rate (mm/min)	Revolution (min ⁻¹)	Feed rate (mm/min)
16	2400	670	1400	380	1400	170
20	1900	610	1100	350	1100	130
Depth of cut						

DC:Dia.

Note 1) If the depth of cut is shallow, the revolution and feed rate can be increased.

Note 2) The irregular helix flute end mill has a larger effect on controlling vibration when compared to standard end mills. However, if the rigidity of the machine or the workpiece installation is poor, vibration or abnormal sound can occur. In this case, please reduce the revolution and feed rate proportionately, or set a lower depth of cut.

IMPACT MIRACLE END MILLS

VF8MHVRBCH

Corner radius end mill. Medium cut length, Irregular helix, 8 flute. With multiple internal through coolant holes.



CARBIDE

Carbon Steel, Alloy Steel, Cast Iron (<30HRC)	Tool Steel, Pre-Hardened Steel, Hardened Steel (≤45HRC)	Hardened Steel (≤55HRC)	Hardened Steel (>55HRC)	Austenitic Stainless Steel	Titanium Alloy, Heat Resistant Alloy	Copper Alloy	Aluminium Alloy
○	○			◎	◎		

CoolStar
END MILLS

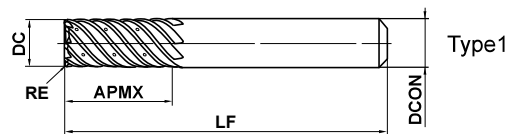

—

SOLID END MILLS

	$1 \leq RE \leq 3$ ± 0.015				
	$16 \leq DC \leq 20$ 0 $- 0.03$				
	$DCON=16$ 0 $- 0.011$	$DCON=20$ 0 $- 0.013$			

● Vibration control corner radius end mill with multiple internal through coolant holes ensures stable machining on difficult-to-cut materials and applications requiring long overhangs. (mm)

Order Number	DC	RE	APMX	LF	DCON	Flutes	Stock	Type
VF8MHVRBCHD1600R100	16	1	32	90	16	8	●	1
VF8MHVRBCHD1600R300	16	3	32	90	16	8	●	1
VF8MHVRBCHD2000R100	20	1	38	100	20	8	●	1
VF8MHVRBCHD2000R300	20	3	38	100	20	8	●	1

SQUARE

BALL

RADIUS

TAPER

BARREL

ROUGHING

● : Inventory maintained.

RECOMMENDED CUTTING CONDITIONS

■ Side milling

Work material	P		M	S	S	
	Alloy steel, Tool steel, Pre-hardened steel X40CrMoV51		Austenitic stainless steel, Titanium alloy X5CrNi1810, X5CrNiMo17-12-2, Ti6Al4V		Heat resistant alloys Inconel718	
Dia. DC (mm)	Revolution (min ⁻¹)	Feed rate (mm/min)	Revolution (min ⁻¹)	Feed rate (mm/min)	Revolution (min ⁻¹)	Feed rate (mm/min)
16	4000	2400	3000	2100	800	240
20	3200	1900	2400	1900	640	200
Depth of cut						

DC: Dia.

■ Trochoidal slotting

Work material	P		M	S
	Alloy steel, Tool steel, Pre-hardened steel X40CrMoV51		Austenitic stainless steel, Titanium alloy X5CrNi1810, X5CrNiMo17-12-2, Ti6Al4V	
Dia. DC (mm)	Revolution (min ⁻¹)	Feed rate (mm/min)	Revolution (min ⁻¹)	Feed rate (mm/min)
16	4000	1900	3000	1400
20	3200	1500	2400	1200
Depth of cut				

DC: Dia.

Note 1) If the depth of cut is shallow, the revolution and feed rate can be increased.

Note 2) The irregular helix flute end mill has a larger effect on controlling vibration when compared to standard end mills. However, if the rigidity of the machine or the workpiece installation is poor, vibration or abnormal sound can occur. In this case, please reduce the revolution and feed rate proportionately, or set a lower depth of cut.

IMPACT MIRACLE END MILLS

VFSFPR

Roughing end mill, Short cut length, 3/4 flutes



DC < 8

DC ≥ 8

Carbon Steel, Alloy Steel, Cast Iron (<30HRC)	Tool Steel, Pre-Hardened Steel, Hardened Steel (≤45HRC)	Hardened Steel (≤55HRC)	Hardened Steel (>55HRC)	Austenitic Stainless Steel	Titanium Alloy, Heat Resistant Alloy	Copper Alloy	Aluminium Alloy
○	○			◎	◎		

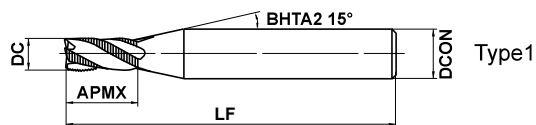

h6	DCON=6	8 ≤ DCON ≤ 10	12 ≤ DCON ≤ 16	DCON=20
	0 - 0.008	0 - 0.009	0 - 0.011	0 - 0.013

● IMPACT MIRACLE roughing end mills for a wide range of work materials from carbon and alloy steel through to hardened steel and difficult-to-cut materials.

(mm)

Order Number	DC	APMX	LF	DCON	Flutes	Stock	Type
VFSFPRD0300	3	6	50	6	3	●	1
VFSFPRD0400	4	8	50	6	3	●	1
VFSFPRD0500	5	10	50	6	3	●	1
VFSFPRD0600	6	12	50	6	3	●	2
VFSFPRD0700	7	17	60	8	3	●	1
VFSFPRD0800	8	17	60	8	4	●	2
VFSFPRD0900	9	22	70	10	4	●	1
VFSFPRD1000S08	10	22	90	8	4	●	3
VFSFPRD1000	10	22	70	10	4	●	2
VFSFPRD1200S10	12	27	100	10	4	●	3
VFSFPRD1200	12	27	75	12	4	●	2
VFSFPRD1400	14	27	75	12	4	●	3
VFSFPRD1600	16	33	90	16	4	●	2
VFSFPRD1800	18	33	90	16	4	●	3
VFSFPRD2000	20	38	100	20	4	●	2

● : Inventory maintained.

CARBIDE

SOLID END MILLS

SQUARE

BALL

RADIUS

TAPER

BARREL

ROUGHING

RECOMMENDED CUTTING CONDITIONS

■ Side milling

Work material	P				M	S	H		S	
	Carbon steel, Cast iron, Alloy steel (—30HRC) Cf53, GG25		Alloy steel, Tool steel, Pre-hardened steel X40CrMoV51		Austenitic stainless steel, Titanium alloy X5CrNi1810, X5CrNiMo17-12-2, Ti6Al4V		Hardened steel (45—55HRC) X40CrMoV51		Heat resistant alloys Inconel718	
Dia. DC (mm)	Revolution (min ⁻¹)	Feed rate (mm/min)	Revolution (min ⁻¹)	Feed rate (mm/min)	Revolution (min ⁻¹)	Feed rate (mm/min)	Revolution (min ⁻¹)	Feed rate (mm/min)	Revolution (min ⁻¹)	Feed rate (mm/min)
3	16000	960	13000	640	6400	260	5300	320	4200	70
4	12000	960	9500	640	4800	260	4000	320	3200	70
5	9500	960	7600	640	3800	260	3200	320	2500	70
6	8000	960	6400	680	3200	290	2700	340	2100	75
8	6000	1050	4800	760	2400	340	2000	400	1600	95
10	4800	1050	3800	760	1900	340	1600	400	1300	105
12	4000	960	3200	700	1600	320	1300	400	1100	110
16	3000	840	2400	620	1200	300	1000	360	800	110
20	2400	760	1900	560	1000	300	800	320	600	100

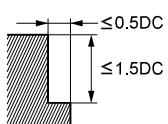
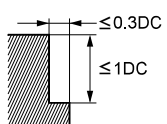
Depth of cut		
--------------	---	---

DC: Dia.

■ Slotting

Work material	P				M	S	H		S	
	Carbon steel, Cast iron, Alloy steel (—30HRC) Cf53, GG25		Alloy steel, Tool steel, Pre-hardened steel X40CrMoV51		Austenitic stainless steel, Titanium alloy X5CrNi1810, X5CrNiMo17-12-2, Ti6Al4V		Hardened steel (45—55HRC) X40CrMoV51		Heat resistant alloys Inconel718	
Dia. DC (mm)	Revolution (min ⁻¹)	Feed rate (mm/min)	Revolution (min ⁻¹)	Feed rate (mm/min)	Revolution (min ⁻¹)	Feed rate (mm/min)	Revolution (min ⁻¹)	Feed rate (mm/min)	Revolution (min ⁻¹)	Feed rate (mm/min)
3	13000	720	11000	480	4800	190	3200	190	2100	25
4	9500	720	8000	480	3600	190	2400	190	1600	25
5	7600	720	6400	480	3200	190	1900	190	1300	25
6	6400	720	5300	480	2700	200	1600	200	1100	30
8	4800	800	4000	520	2000	220	1200	220	800	35
10	3800	800	3200	520	1600	220	1000	220	600	35
12	3200	750	2700	520	1300	210	800	210	500	40
16	2400	620	2000	450	1000	180	600	180	400	45
20	1900	540	1600	400	800	160	500	160	300	40

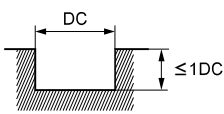
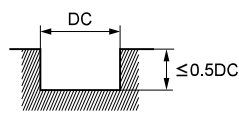
Depth of cut		
--------------	---	---

DC: Dia.

Note 1) When cutting austenitic stainless steels, the use of water-soluble cutting fluid is effective.

Note 2) If the depth of cut is shallow, the revolution and feed rate can be increased.

Note 3) If the rigidity of the machine or the work materials installation is very low, or chattering and noise are generated, reduce the revolution and feed rate proportionately.

IMPACT MIRACLE END MILLS

VFMFPR

Roughing end mill, Medium cut length, 4 flute



Carbon Steel, Alloy Steel, Cast Iron (<30HRC)	Tool Steel, Pre-Hardened Steel, Hardened Steel (≤45HRC)	Hardened Steel (≤55HRC)	Hardened Steel (>55HRC)	Austenitic Stainless Steel	Titanium Alloy, Heat Resistant Alloy	Copper Alloy	Aluminium Alloy
---	---	-------------------------	-------------------------	----------------------------	--------------------------------------	--------------	-----------------

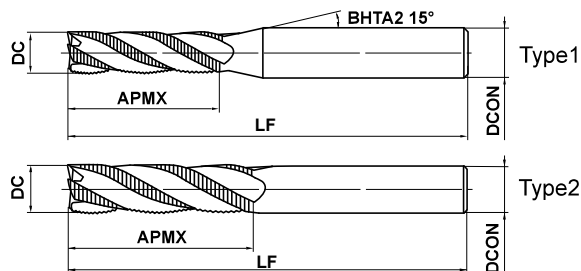

h6	DCON=6	8 ≤ DCON ≤ 10	12 ≤ DCON ≤ 16	DCON=20
	0 - 0.008	0 - 0.009	0 - 0.011	0 - 0.013

● IMPACT MIRACLE roughing end mills suitable for the machining of deep walled components.

(mm)

Order Number	DC	APMX	LF	DCON	Flutes	Stock	Type
VFMFPRD0500	5	15	60	6	4	●	1
VFMFPRD0600	6	17	60	6	4	●	2
VFMFPRD0700	7	22	75	8	4	●	1
VFMFPRD0800	8	28	75	8	4	●	2
VFMFPRD0900	9	28	100	10	4	●	1
VFMFPRD1000	10	34	100	10	4	●	2
VFMFPRD1200	12	40	110	12	4	●	2
VFMFPRD1600	16	48	125	16	4	●	2
VFMFPRD2000	20	57	140	20	4	●	2

RECOMMENDED CUTTING CONDITIONS

Side milling

Work material	P		M		S		H			
	Revolution (min ⁻¹)	Feed rate (mm/min)	Revolution (min ⁻¹)	Feed rate (mm/min)	Revolution (min ⁻¹)	Feed rate (mm/min)	Revolution (min ⁻¹)	Feed rate (mm/min)	Revolution (min ⁻¹)	Feed rate (mm/min)
Carbon steel, Cast iron, Alloy steel (−30HRC) Cf53, GG25			Alloy steel, Tool steel, Pre-hardened steel X40CrMoV51		Austenitic stainless steel, Titanium alloy X5CrNi1810, X5CrNiMo17-12-2, Ti6Al4V		Hardened steel (45–55HRC) X40CrMoV51		Heat resistant alloys Inconel718	
5	3800	360	3200	290	2500	150	2500	150	1900	50
6	3200	360	2700	290	2100	160	2100	160	1600	60
8	2400	450	2000	360	1600	160	1600	160	1200	70
10	1900	450	1600	360	1300	180	1300	180	1000	75
12	1600	400	1300	320	1100	180	1100	180	800	80
16	1200	360	1000	290	800	160	800	160	600	80
20	1000	340	800	270	600	150	600	150	500	80

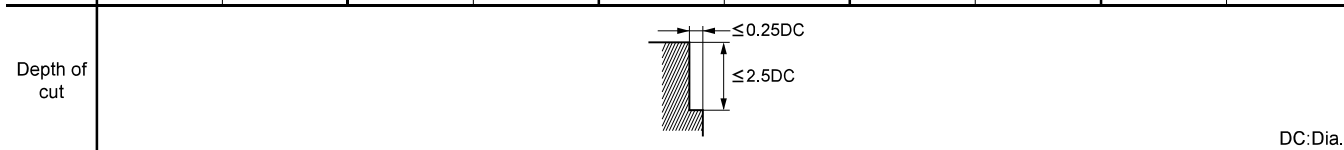

DC: Dia.

Note 1) When cutting austenitic stainless steels, the use of water-soluble cutting fluid is effective.

Note 2) If the depth of cut is shallow, the revolution and feed rate can be increased.

Note 3) If the rigidity of the machine or the work materials installation is very low, or chattering and noise are generated, reduce the revolution and feed rate proportionately.

● : Inventory maintained.

VFSFPRCH

Roughing end mill, Short cut length, 4 flute.
With multiple internal through coolant holes.



CARBIDE

Carbon Steel, Alloy Steel, Cast Iron (<30HRC)	Tool Steel, Pre-Hardened Steel, Hardened Steel (≤45HRC)	Hardened Steel (≤55HRC)	Hardened Steel (>55HRC)	Austenitic Stainless Steel	Titanium Alloy, Heat Resistant Alloy	Copper Alloy	Aluminium Alloy
○	○			⊙	⊙		

CoolStar
END MILLS

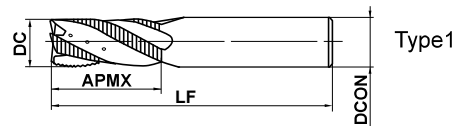

h6	DCON=16	DCON=20			
	0 - 0.011	0 - 0.013			

● Roughing end mill with multiple internal through coolant holes suitable for difficult-to-cut materials.

Order Number	DC	APMX	LF	DCON	Flutes	Stock	Type
VFSFPRCHD1600	16	33	90	16	4	●	1
VFSFPRCHD2000	20	38	100	20	4	●	1

RECOMMENDED CUTTING CONDITIONS

■ Side milling

Work material	P				M	S	S	
	Carbon steel, Cast iron, Alloy steel (—30HRC) Cf53, GG25		Alloy steel, Tool steel, Pre-hardened steel (—45HRC) X40CrMoV51		Austenitic stainless steel, Titanium alloy X5CrNi1810, X5CrNiMo17-12-2, Ti6Al4V	Heat resistant alloys Inconel718	Revolution (min ⁻¹)	Feed rate (mm/min)
Dia. DC (mm)	Revolution (min ⁻¹)	Feed rate (mm/min)	Revolution (min ⁻¹)	Feed rate (mm/min)	Revolution (min ⁻¹)	Feed rate (mm/min)	Revolution (min ⁻¹)	Feed rate (mm/min)
16	3000	840	2400	620	1200	300	800	110
20	2400	760	1900	560	1000	300	600	100
Depth of cut								

■ Slotting

Work material	P				M	S
	Carbon steel, Cast iron, Alloy steel (—30HRC) Cf53, GG25		Alloy steel, Tool steel, Pre-hardened steel (—45HRC) X40CrMoV51		Austenitic stainless steel, Titanium alloy X5CrNi1810, X5CrNiMo17-12-2, Ti6Al4V	Feed rate (mm/min)
Dia. DC (mm)	Revolution (min ⁻¹)	Feed rate (mm/min)	Revolution (min ⁻¹)	Feed rate (mm/min)	Revolution (min ⁻¹)	Feed rate (mm/min)
16	2400	620	2000	450	800	100
20	1900	540	1600	400	600	80
Depth of cut						

Note 1) If the depth of cut is shallow, the revolution and feed rate can be increased.

Note 2) If the rigidity of the machine or the work materials installation is very low, or chattering and noise are generated, reduce the revolution and feed rate proportionately.

DC: Dia.

SOLID END MILLS

SQUARE

BALL

RADIUS

TAPER

BARREL

ROUGHING

IMPACT MIRACLE END MILLS

VF6SVRCH

Roughing end mill, Short cut length, Irregular helix, 6 flute. With multiple internal through coolant holes.



Carbon Steel, Alloy Steel, Cast Iron (<30HRC)	Tool Steel, Pre-Hardened Steel, Hardened Steel (≤45HRC)	Hardened Steel (≤55HRC)	Hardened Steel (>55HRC)	Austenitic Stainless Steel	Titanium Alloy, Heat Resistant Alloy	Copper Alloy	Aluminium Alloy
○	○			◎	◎		

CoolStar
END MILLS

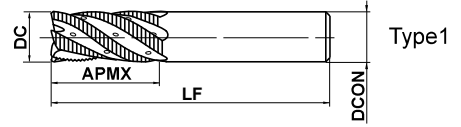

SOLID END MILLS

h6	DCON=16	DCON=20			
	0 - 0.011	0 - 0.013			

● Roughing end mill with multiple internal through coolant holes suitable for difficult-to-cut materials.

(mm)

Order Number	DC	APMX	LF	DCON	Flutes	Stock	Type
VF6SVRCHD1600	16	33	90	16	6	●	1
VF6SVRCHD2000	20	38	100	20	6	●	1

SQUARE

BALL

RADIUS

TAPER

BARREL

ROUGHING

RECOMMENDED CUTTING CONDITIONS

Side milling

Work material	P		M	S	S	
	Revolution (min ⁻¹)	Feed rate (mm/min)	Revolution (min ⁻¹)	Feed rate (mm/min)	Revolution (min ⁻¹)	Feed rate (mm/min)
Alloy steel, Tool steel, Pre-hardened steel X40CrMoV51			Austenitic stainless steel, Titanium alloy X5CrNi1810, X5CrNiMo17-12-2, Ti6Al4V		Heat resistant alloys Inconel718	
16	3000	1500	2400	1200	800	160
20	2400	1200	2000	1000	640	140
Depth of cut						

DC: Dia.

Note 1) If the depth of cut is shallow, the revolution and feed rate can be increased.

Note 2) The irregular helix flute end mill has a larger effect on controlling vibration when compared to standard end mills. However, if the rigidity of the machine or the workpiece installation is poor, vibration or abnormal sound can occur. In this case, please reduce the revolution and feed rate proportionately, or set a lower depth of cut.

● : Inventory maintained.

VQN END MILLS

VQN2MB NEW

Ball nose, Medium cut length, 2 flute



CARBIDE

Carbon Steel, Alloy Steel, Cast Iron (<30HRC)	Tool Steel, Pre-Hardened Steel, Hardened Steel (<=45HRC)	Hardened Steel (<=55HRC)	Hardened Steel (>55HRC)	Austenitic Stainless Steel	Heat Resistant Alloy	Copper Alloy	Aluminium Alloy
---	--	--------------------------	-------------------------	----------------------------	----------------------	--------------	-----------------

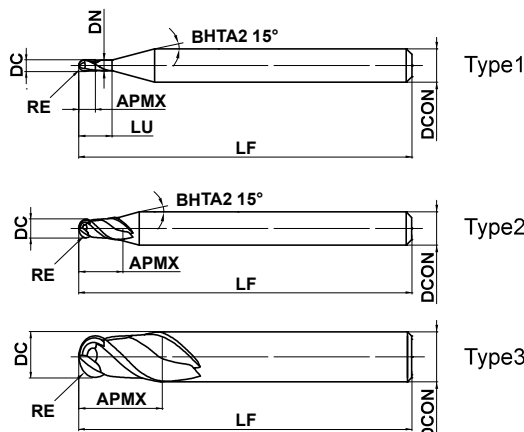

RE ≤ 6		
±0.010		



DCON=6	8 ≤ DCON ≤ 10	DCON=12
0 - 0.005	0 - 0.006	0 - 0.008

- (Al, Ti, Si) N-based coating has excellent wear and chipping resistance when machining heat resistant super alloys.
- The R cutting edge rake angle and ball nose geometry have been optimised to improve strength.

(mm)

Order Number	RE	DC	APMX	LU	DN	LF	DCON	Flutes	Stock	Type
VQN2MBR0050	0.5	1	1	4	0.94	60	6	2	●	1
VQN2MBR0100	1.0	2	2	6	1.9	60	6	2	●	1
VQN2MBR0150	1.5	3	3	8	2.9	60	6	2	●	1
VQN2MBR0200	2.0	4	8	—	—	60	6	2	●	2
VQN2MBR0250	2.5	5	12	—	—	60	6	2	●	2
VQN2MBR0300	3.0	6	12	—	—	60	6	2	●	3
VQN2MBR0400	4.0	8	14	—	—	70	8	2	●	3
VQN2MBR0500	5.0	10	18	—	—	80	10	2	●	3
VQN2MBR0600	6.0	12	22	—	—	80	12	2	●	3

RECOMMENDED CUTTING CONDITIONS

Work material	S					
	Nickel-based Heat Resistant Super Alloy					
	Inconel718, Inconel713C, Waspaloy etc.					
RE (mm)	α ≤ 15°		α > 15°		Depth of cut ap (mm)	Depth of cut ae (mm)
	Revolution (min ⁻¹)	Feed rate (mm/min)	Revolution (min ⁻¹)	Feed rate (mm/min)		
0.5	12700	640	12700	760	0.1	0.25
1.0	6300	320	6300	380	0.2	0.50
1.5	4200	250	4200	250	0.3	0.75
2.0	3100	190	3100	220	0.4	1.00
2.5	2500	180	2500	200	0.5	1.25
3.0	2100	170	2100	210	0.6	1.50
4.0	1500	130	1500	160	0.8	2.00
5.0	1200	130	1200	140	1.0	2.50
6.0	1000	110	1000	120	1.2	3.00

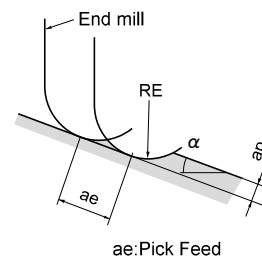
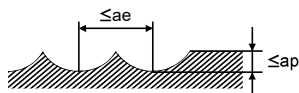

- Note 1) For heat resistant super alloys, the use of water-soluble coolant is effective.
- Note 2) If the depth of cut is shallow, the revolution and feed rate can be increased.
- Note 3) Vibration may occur if the rigidity of machine or workpiece is low. In this case, please reduce the revolution and feed rate proportionately.
- Note 4) α is the inclination angle of the machined surface.

SOLID END MILLS

SQUARE

BALL

RADIUS

TAPER

BARREL

ROUGHING

VQN END MILLS

VQN4MB NEW

Ball nose, Medium cut length, 4 flute



Carbon Steel, Alloy Steel, Cast Iron (<30HRC)	Tool Steel, Pre-Hardened Steel, Hardened Steel (≤45HRC)	Hardened Steel (≤55HRC)	Hardened Steel (>55HRC)	Austenitic Stainless Steel	Heat Resistant Alloy	Copper Alloy	Aluminium Alloy
---	---	-------------------------	-------------------------	----------------------------	----------------------	--------------	-----------------

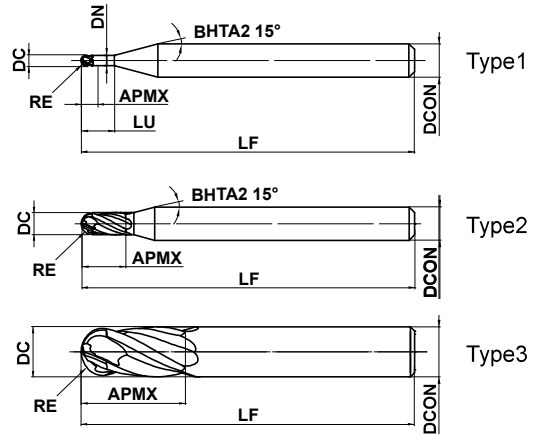

	RE ≤ 6		
	±0.010		
	DCON=6	8 ≤ DCON ≤ 10	DCON=12
	$\begin{matrix} 0 \\ -0.005 \end{matrix}$	$\begin{matrix} 0 \\ -0.006 \end{matrix}$	$\begin{matrix} 0 \\ -0.008 \end{matrix}$

- (Al, Ti, Si) N-based coating has excellent wear and chipping resistance when machining heat resistant super alloys.
- The 2-flute end cutting edge provides excellent chip evacuation and is ideal for rough machining.

(mm)

Order Number	RE	DC	APMX	LU	DN	LF	DCON	Flutes	Stock	Type
VQN4MBR0100	1.0	2	2	6	1.9	60	6	4	●	1
VQN4MBR0150	1.5	3	3	8	2.9	60	6	4	●	1
VQN4MBR0200	2.0	4	8	—	—	60	6	4	●	2
VQN4MBR0250	2.5	5	12	—	—	60	6	4	●	2
VQN4MBR0300	3.0	6	12	—	—	60	6	4	●	3
VQN4MBR0400	4.0	8	14	—	—	70	8	4	●	3
VQN4MBR0500	5.0	10	18	—	—	80	10	4	●	3
VQN4MBR0600	6.0	12	22	—	—	80	12	4	●	3

RECOMMENDED CUTTING CONDITIONS

Work material	S					
	Nickel-based Heat Resistant Super Alloy					
	Inconel718, Inconel713C, WSPALLOY etc.					
RE (mm)	$\alpha \leq 15^\circ$		$\alpha > 15^\circ$		Depth of cut a_p (mm)	Depth of cut a_e (mm)
	Revolution (min ⁻¹)	Feed rate (mm/min)	Revolution (min ⁻¹)	Feed rate (mm/min)		
1.0	6300	380	6300	510	0.2	0.50
1.5	4200	340	4200	420	0.3	0.75
2.0	3100	320	3100	380	0.4	1.00
2.5	2500	250	2500	310	0.5	1.25
3.0	2100	210	2100	250	0.6	1.50
4.0	1500	160	1500	190	0.8	2.00
5.0	1200	150	1200	200	1.0	2.50
6.0	1000	150	1000	170	1.2	3.00

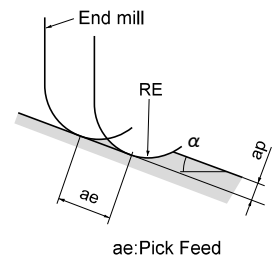

- Note 1) For machining heat resistant super alloys, the use of water-soluble coolant is effective.
- Note 2) If the depth of cut is shallow, the revolution and feed rate can be increased.
- Note 3) Vibration may occur if the rigidity of machine or workpiece is low. In this case, please reduce the revolution and feed rate proportionately.
- Note 4) α is the inclination angle of the machined surface.

● : Inventory maintained.

VQN4MBF NEW

Ball nose, Medium cut length, 4 flute



CARBIDE

Carbon Steel, Alloy Steel, Cast Iron (<30HRC)	Tool Steel, Pre-Hardened Steel, Hardened Steel (≤45HRC)	Hardened Steel (≤55HRC)	Hardened Steel (>55HRC)	Austenitic Stainless Steel	Heat Resistant Alloy	Copper Alloy	Aluminium Alloy
---	---	-------------------------	-------------------------	----------------------------	----------------------	--------------	-----------------

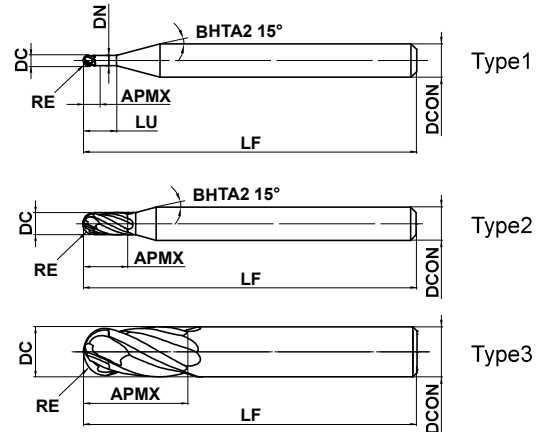

RE ≤ 6		
±0.010		
DCON=6	8 ≤ DCON ≤ 10	DCON=12
0 - 0.005	0 - 0.006	0 - 0.008

- (Al, Ti, Si) N-based coating has excellent wear and chipping resistance when machining heat resistant super alloys.
- The 4-flute end cutting edge is also ideal for 5-axis machining.

(mm)

Order Number	RE	DC	APMX	LU	DN	LF	DCON	Flutes	Stock	Type
VQN4MBFR0100	1.0	2	2	6	1.9	60	6	4	●	1
VQN4MBFR0150	1.5	3	3	8	2.9	60	6	4	●	1
VQN4MBFR0200	2.0	4	8	—	—	60	6	4	●	2
VQN4MBFR0250	2.5	5	12	—	—	60	6	4	●	2
VQN4MBFR0300	3.0	6	12	—	—	60	6	4	●	3
VQN4MBFR0400	4.0	8	14	—	—	70	8	4	●	3
VQN4MBFR0500	5.0	10	18	—	—	80	10	4	●	3
VQN4MBFR0600	6.0	12	22	—	—	80	12	4	●	3

RECOMMENDED CUTTING CONDITIONS

Work material	S						
	Nickel-based Heat Resistant Super Alloy						
	Inconel718, Inconel713C, Waspaloy etc.						
RE (mm)	α ≤ 15°			α > 15°			Depth of cut ap (mm)
	Revolution (min ⁻¹)	Feed rate (mm/min)	Depth of cut ae (mm)	Revolution (min ⁻¹)	Feed rate (mm/min)	Depth of cut ae (mm)	
1.0	6300	180	0.40	6300	310	0.50	0.2
1.5	4200	170	0.60	4200	340	0.75	0.3
2.0	3100	190	0.80	3100	320	1.00	0.4
2.5	2500	150	1.00	2500	250	1.25	0.5
3.0	2100	170	1.20	2100	250	1.50	0.6
4.0	1500	130	1.60	1500	190	2.00	0.8
5.0	1200	100	2.00	1200	200	2.50	1.0
6.0	1000	130	2.40	1000	170	3.00	1.2

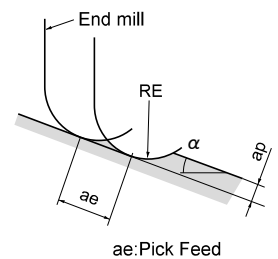
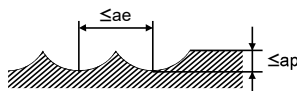

- Note 1) For machining heat resistant super alloys, the use of water-soluble coolant is effective.
- Note 2) If the depth of cut is shallow, the revolution and feed rate can be increased.
- Note 3) Vibration may occur if the rigidity of machine or workpiece is low. In this case, please reduce the revolution and feed rate proportionately.
- Note 4) α is the inclination angle of the machined surface.

SOLID END MILLS

SQUARE

BALL

RADIUS

TAPER

BARREL

ROUGHING

VQ END MILLS

VQ4SVB

Ball nose, Short cut length, Variable helix, 4 flute



Carbon Steel, Alloy Steel, Cast Iron (<30HRC)	Tool Steel, Pre-Hardened Steel, Hardened Steel (≤45HRC)	Hardened Steel (≤55HRC)	Hardened Steel (>55HRC)	Austenitic Stainless Steel	Titanium Alloy, Heat Resistant Alloy	Copper Alloy	Aluminium Alloy
○	○			○	○	○	

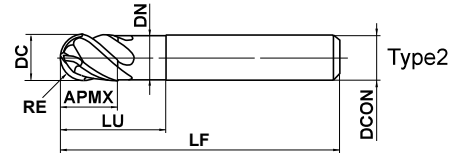
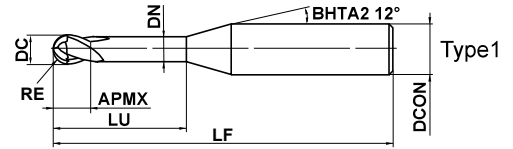

SOLID END MILLS

	1 ≤ RE ≤ 6				
	±0.010				
	DC ≤ 12				
	⁰ / _{-0.020}				
	DCON=6	8 ≤ DCON ≤ 10	DCON=20		
	⁰ / _{-0.008}	⁰ / _{-0.009}	⁰ / _{-0.011}		

- 4 flute vibration control ball nose end mill with VQ coating.
- Ideal for finishing.

(mm)

Order Number	RE	DC	APMX	LU	DN	LF	DCON	Flutes	Stock	Type
VQ4SVBR0100	1	2	3	5	1.9	50	6	4	●	1
VQ4SVBR0150	1.5	3	4.5	7.5	2.9	50	6	4	●	1
VQ4SVBR0200	2	4	6	10	3.9	50	6	4	●	1
VQ4SVBR0250	2.5	5	7.5	12.5	4.9	50	6	4	●	1
VQ4SVBR0300	3	6	9	15	5.85	50	6	4	●	2
VQ4SVBR0400	4	8	12	20	7.85	60	8	4	●	2
VQ4SVBR0500	5	10	15	25	9.7	70	10	4	●	2
VQ4SVBR0600	6	12	18	30	11.7	75	12	4	●	2

SQUARE

BALL

RADIUS

TAPER

BARREL

ROUGHING

● : Inventory maintained.

RECOMMENDED CUTTING CONDITIONS

Shoulder milling (Slotting)

Material	P								M			S				
	Carbon steel, Alloy steel, Mild steel, Pre-hardened steel								Austenitic stainless steel, Titanium alloy, Hardened stainless steels, Cobalt chromium alloy, Ferritic and Martensitic stainless steels							
	Ck45, 41CrMo4, 36CrNiMo4, X5CrNi189, X5CrNiMo1810, X2CrNi1810, X2CrNiMoN1813								Inconel 718, NAK, X36CrMo17, X40CrMoV51, 55NiCrMoV6, X46Cr13							
RE (mm)	$\alpha \leq 15^\circ$			$\alpha > 15^\circ$			Depth of cut ap (mm)	Depth of cut ae (mm)	$\alpha \leq 15^\circ$			$\alpha > 15^\circ$			Depth of cut ap (mm)	Depth of cut ae (mm)
	Cutting speed (m/min)	Revolution (min ⁻¹)	Feed rate (mm/min)	Cutting speed (m/min)	Revolution (min ⁻¹)	Feed rate (mm/min)			Cutting speed (m/min)	Revolution (min ⁻¹)	Feed rate (mm/min)	Cutting speed (m/min)	Revolution (min ⁻¹)	Feed rate (mm/min)		
R 1	250	40000	8000	200	32000	3800	0.17	0.5	230	36000	6500	150	24000	2900	0.17	0.5
R 1.5	300	32000	7700	200	21000	3200	0.25	0.75	230	24000	4800	150	16000	1900	0.25	0.75
R 2	300	24000	5800	200	16000	2800	0.33	1	230	18000	4000	150	12000	1700	0.33	1
R 2.5	300	19000	5300	200	12700	2600	0.42	1.25	230	14400	3500	150	9600	1500	0.42	1.25
R 3	300	16000	4800	200	10600	2100	0.5	1.5	230	12000	3200	150	8000	1400	0.5	1.5
R 4	300	12000	4300	200	8000	1900	0.8	2	230	9000	3200	150	6000	1400	0.8	2
R 5	300	9600	4100	200	6400	1800	1	2.5	230	7200	3000	150	4800	1300	1	2.5
R 6	300	8000	4000	200	5300	1800	1.2	3	230	6000	3000	150	4000	1300	1.2	3

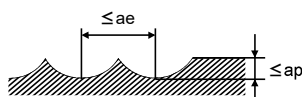

RE:Radius

Material	N								S							
	Copper, Copper alloy								Heat resistant alloys Inconel etc.							
	RE (mm)	$\alpha \leq 15^\circ$			$\alpha > 15^\circ$			Depth of cut ap (mm)	Depth of cut ae (mm)	$\alpha \leq 15^\circ$			$\alpha > 15^\circ$			Depth of cut ap (mm)
Cutting speed (m/min)		Revolution (min ⁻¹)	Feed rate (mm/min)	Cutting speed (m/min)	Revolution (min ⁻¹)	Feed rate (mm/min)	Cutting speed (m/min)			Revolution (min ⁻¹)	Feed rate (mm/min)	Cutting speed (m/min)	Revolution (min ⁻¹)	Feed rate (mm/min)		
R 1	250	40000	8000	240	38000	4500	0.17	0.5	60	9600	960	40	6400	510	0.08	0.2
R 1.5	360	38000	9100	240	25000	3800	0.25	0.7	60	6400	640	40	4200	340	0.13	0.3
R 2	360	29000	7000	240	19000	3300	0.33	1	60	4800	580	40	3200	260	0.17	0.4
R 2.5	360	23000	6400	240	15000	3100	0.42	1.2	60	3800	530	39	2500	250	0.21	0.5
R 3	360	19000	5700	240	13000	2600	0.5	1.5	60	3200	500	40	2100	210	0.25	0.6
R 4	360	14000	5000	240	9600	2300	0.8	2	60	2400	430	40	1600	190	0.4	0.8
R 5	360	12000	5100	240	7700	2200	1	2.5	63	2000	420	41	1300	180	0.5	1
R 6	360	9600	4800	240	6400	2200	1.2	3	64	1700	350	41	1100	150	0.6	1.2

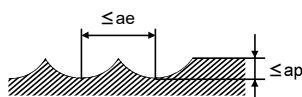

RE:Radius

- Note 1) VQ coating has less electrical conductivity; therefore an external contact type (electrically transmitted) tool setter may not work. When measuring the tool length, please use an internal contact type (non-electrical type) tool setter or a laser type tool setter.
- Note 2) Effective cutting of stainless steel, titanium alloys and heat-resistant alloys etc. can be achieved with the use of emulsion coolant.
- Note 3) Chattering can still occur if the machine rigidity and clamping method are insufficient. In these cases the feed and speed should be reduced proportionately.
- Note 4) When the depth of cut is smaller than shown the revolution and feed rate can be increased.
- Note 5) α is the inclination angle of the machined surface.

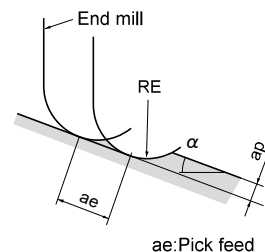

SOLID END MILLS

SQUARE

BALL

RADIUS

TAPER

BARREL

ROUGHING

VQ END MILLS

VQ4WB NEW

Lollipop ball nose, Short cut length, 4 flute



Carbon Steel, Alloy Steel, Cast Iron (<30HRC)	Tool Steel, Pre-Hardened Steel, Hardened Steel (≤45HRC)	Hardened Steel (≤55HRC)	Hardened Steel (>55HRC)	Austenitic Stainless Steel	Titanium Alloy, Heat Resistant Alloy	Copper Alloy	Aluminium Alloy
◎	◎			◎	◎	○	

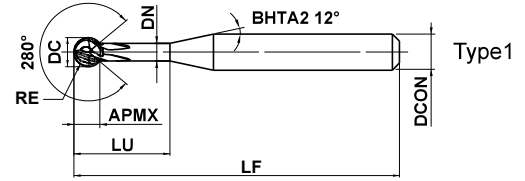

SOLID END MILLS



$0.5 \leq RE \leq 3$

± 0.01



$4 \leq DCON \leq 6$

$\begin{matrix} 0 \\ -0.008 \end{matrix}$

- Multi-functional ball end mill with a lollipop geometry for 5-axis machining.
- Optimal for back deburring, undercutting and inner curved surface machining.

(mm)

Order Number	RE	DC	APMX	LU	DN	LF	DCON	Flutes	Stock	Type
VQ4WBR0050N06E280	0.5	1.0	0.88	6	0.61	50	4	4	●	1
VQ4WBR0065N08E280	0.65	1.3	1.14	8	0.80	50	4	4	●	1
VQ4WBR0090N06E280	0.9	1.8	1.58	6	1.11	50	4	4	●	1
VQ4WBR0100N06E280	1.0	2.0	1.76	6	1.24	60	6	4	●	1
VQ4WBR0140N16E280	1.4	2.8	2.47	16	1.74	60	6	4	●	1
VQ4WBR0150N08E280	1.5	3.0	2.64	8	1.87	60	6	4	●	1
VQ4WBR0190N12E280	1.9	3.8	3.35	12	2.37	60	6	4	●	1
VQ4WBR0200N12E280	2.0	4.0	3.53	12	2.50	60	6	4	●	1
VQ4WBR0240N16E280	2.4	4.8	4.23	16	3.00	70	6	4	●	1
VQ4WBR0250N12E280	2.5	5.0	4.41	12	3.13	80	6	4	●	1
VQ4WBR0300N12E280	3.0	6.0	5.29	12	3.76	80	6	4	●	1

<Special Orders>

For non standard products not shown above, please contact our sales department.

● : Inventory maintained.

SQUARE

BALL

RADIUS

TAPER

BARREL

ROUGHING

RECOMMENDED CUTTING CONDITIONS

■ Chamfering (Deburring)

Work material		P	N	M	S		
		Mild steels, Carbon steels, Copper alloys, Pre-hardened steels Ck45, 41CrMo4, 36CrNiMo4, X5CrNi189, X5CrNiMo1810, X2CrNiN1810, X2CrNiMoN1813			Austenitic, Ferritic and Martensitic stainless steels, Precipitation hardening stainless steels, Cobalt chromium alloys, Titanium alloys Inconel 718, NAK, X36CrMo17, X40CrMoV51, 55NiCrMoV6, X46Cr13		
Dia. DC (mm)	RE (mm)	Revolution (min ⁻¹)	Feed rate (mm/min)	Depth of cut Max.CF (mm)	Revolution (min ⁻¹)	Feed rate (mm/min)	Depth of cut Max.CF (mm)
1.0	0.5	19000	300	0.10	14000	220	0.10
1.3	0.65	15000	420	0.13	11000	310	0.13
1.8	0.9	11000	570	0.18	8000	420	0.18
2.0	1.0	9500	610	0.20	7200	460	0.20
2.8	1.4	6800	760	0.28	5100	570	0.28
3.0	1.5	6400	770	0.30	4800	580	0.30
3.8	1.9	5000	840	0.38	3800	640	0.38
4.0	2.0	4800	880	0.40	3600	660	0.40
4.8	2.4	4000	960	0.48	3000	720	0.48
5.0	2.5	3800	970	0.50	2900	740	0.50
6.0	3.0	3200	1000	0.60	2400	770	0.60

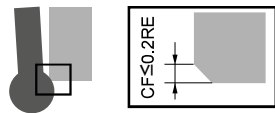
Depth of cut		
	RE : Radius	

SOLID END MILLS

SQUARE

BALL

RADIUS

TAPER

BARREL

ROUGHING

■ Internal profile / Undercut

Work material		P	N	M	S		
		Mild steels, Carbon steels, Copper alloys, Pre-hardened steels Ck45, 41CrMo4, 36CrNiMo4, X5CrNi189, X5CrNiMo1810, X2CrNiN1810, X2CrNiMoN1813			Austenitic, Ferritic and Martensitic stainless steels, Precipitation hardening stainless steels, Cobalt chromium alloys, Titanium alloys Inconel 718, NAK, X36CrMo17, X40CrMoV51, 55NiCrMoV6, X46Cr13		
Dia. DC (mm)	RE (mm)	Revolution (min ⁻¹)	Feed rate (mm/min)	Depth of cut ae (mm)	Revolution (min ⁻¹)	Feed rate (mm/min)	Depth of cut ae (mm)
2.0	1.0	9500	460	0.03	7200	290	0.03
3.0	1.5	6400	560	0.10	4800	350	0.10
4.0	2.0	4800	650	0.14	3600	390	0.14
5.0	2.5	3800	730	0.18	2900	440	0.18
6.0	3.0	3200	770	0.22	2400	460	0.22

Depth of cut		
	RE : Radius	

Note 1) VQ coating has less electrical conductivity; therefore an external contact type (electrically transmitted) tool setter may not work.

When measuring the tool length, please use an internal contact type (non-electrical type) tool setter or a laser type tool setter.

Note 2) If the depth of cut is smaller than this table, feed rate can be increased.

Note 3) If the rigidity of the machine or the workpiece installation is very low, or chattering is generated, please reduce the revolution and the feed rate proportionately.

Note 4) For sizes RE 0.5, 0.65, 0.9, 1.4, 1.9 and RE 2.4 which have long neck lengths, internal profile milling and round shape slotting are not recommended.

VQ END MILLS

VQ4WB NEW

Lollipop ball nose, Short cut length, 4 flute

CARBIDE

SOLID END MILLS

SQUARE

BALL

RADIUS

TAPER

BARREL

ROUGHING

■ Radiused shape slotting

Work material		P		N		M		S	
		Revolution (min ⁻¹)	Feed rate (mm/min)	Depth of cut ae (mm)	Depth of cut Max. ae (mm)	Revolution (min ⁻¹)	Feed rate (mm/min)	Depth of cut ae (mm)	Depth of cut Max. ae (mm)
Dia. DC (mm)	RE (mm)								
2.0	1.0	9500	300	0.03	0.06	7200	140	0.03	0.06
3.0	1.5	6400	380	0.10	0.20	4800	190	0.10	0.20
4.0	2.0	4800	440	0.14	0.28	3600	230	0.14	0.28
5.0	2.5	3800	490	0.18	0.54	2900	260	0.18	0.54
6.0	3.0	3200	510	0.22	0.88	2400	270	0.22	0.88
Depth of cut									

Note 1) VQ coating has less electrical conductivity; therefore an external contact type (electrically transmitted) tool setter may not work.

When measuring the tool length, please use an internal contact type (non-electrical type) tool setter or a laser type tool setter.

Note 2) If the depth of cut is smaller than this table, feed rate can be increased.

Note 3) If the rigidity of the machine or the workpiece installation is very low, or chattering is generated, please reduce the revolution and the feed rate proportionately.

Note 4) For sizes RE 0.5, 0.65, 0.9, 1.4, 1.9 and RE 2.4 which have long neck lengths, internal profile milling and round shape slotting are not recommended.

Note 5) The maximum allowed depth of cut (Max ae) avoids interference between the workpiece and tool shank. It is recommended to machine up to the Max ae in 2-4 passes.

VQ2XLB NEW

Ball nose, Short cut length, Long neck, 2 flute



CARBIDE

Carbon Steel, Alloy Steel, Cast Iron (<30HRC)	Tool Steel, Pre-Hardened Steel, Hardened Steel (≤45HRC)	Hardened Steel (≤55HRC)	Hardened Steel (>55HRC)	Austenitic Stainless Steel	Titanium Alloy, Heat Resistant Alloy	Copper Alloy	Aluminium Alloy
---	---	-------------------------	-------------------------	----------------------------	--------------------------------------	--------------	-----------------

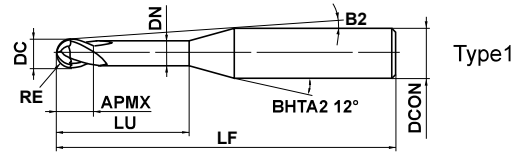

Effective Length for Inclined Angle

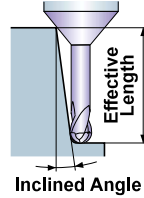

$0.05 \leq RE \leq 1.5$				
± 0.005				



$4 \leq DCON \leq 6$				
0				
$- 0.005$				

● VQ coating providing better wear resistance when machining difficult-to-cut materials.

(mm)

Order Number	RE	DC	APMX	LU	DN	B2	LF	DCON	Flutes	Stock	Type
VQ2XLBR0050N080	0.5	1	0.75	8	0.94	6.4°	50	4	2	●	1
VQ2XLBR0050N100	0.5	1	0.75	10	0.94	5.6°	50	4	2	●	1
VQ2XLBR0050N080S06	0.5	1	0.75	8	0.94	8.3°	50	6	2	●	1
VQ2XLBR0050N100S06	0.5	1	0.75	10	0.94	7.5°	55	6	2	●	1
VQ2XLBR0050N120S06	0.5	1	0.75	12	0.94	6.8°	55	6	2	●	1
VQ2XLBR0075N100S06	0.75	1.5	1.1	10	1.44	7.2°	55	6	2	●	1
VQ2XLBR0075N120S06	0.75	1.5	1.1	12	1.44	6.5°	55	6	2	●	1
VQ2XLBR0100N100	1.0	2	1.5	10	1.9	4.5°	50	4	2	●	1
VQ2XLBR0100N100S06	1.0	2	1.5	10	1.9	6.9°	55	6	2	●	1
VQ2XLBR0100N120	1.0	2	1.5	12	1.9	3.9°	50	4	2	●	1
VQ2XLBR0100N120S06	1.0	2	1.5	12	1.9	6.1°	55	6	2	●	1
VQ2XLBR0150N120	1.5	3	2.3	12	2.9	5.3°	55	6	2	●	1
VQ2XLBR0150N140	1.5	3	2.3	14	2.9	4.7°	60	6	2	●	1
VQ2XLBR0150N160	1.5	3	2.3	16	2.9	4.3°	60	6	2	●	1

● : Inventory maintained.

SOLID END MILLS

SQUARE

BALL

RADIUS

TAPER

BARREL

ROUGHING

VQ END MILLS

VQ2XLB NEW

Ball nose, Short cut length, Long neck, 2 flute

CARBIDE

SOLID END MILLS

SQUARE

BALL

RADIUS

TAPER

BARREL

ROUGHING

RECOMMENDED CUTTING CONDITIONS

Work material		S									
		Titanium alloys					Hardened stainless steels, Cobalt chromium alloy				
RE (mm)	Neck length LU (mm)	Revolution (min ⁻¹)	Cutting speed (m/min)	Feed rate (mm/min)	Depth of cut ap (mm)	Width of cut ae (mm)	Revolution (min ⁻¹)	Cutting speed (m/min)	Feed rate (mm/min)	Depth of cut ap (mm)	Width of cut ae (mm)
0.5	8	32000	100	2500	0.05	0.1	25000	80	2000	0.05	0.1
0.5	10	24000	75	1500	0.05	0.1	19000	60	1500	0.05	0.1
0.5	12	24000	75	1500	0.03	0.1	19000	60	1500	0.03	0.1
0.75	10	21000	100	2100	0.13	0.3	17000	80	1700	0.08	0.1
0.75	12	16000	75	1500	0.13	0.3	13000	60	1200	0.08	0.1
1	10	16000	100	1800	0.20	0.5	13000	80	1500	0.2	0.5
1	12	16000	100	1800	0.20	0.5	13000	80	1500	0.2	0.5
1.5	12	10000	100	1600	0.30	0.8	8500	80	1300	0.3	0.8
1.5	14	10000	100	1600	0.30	0.8	8500	80	1300	0.3	0.8
1.5	16	10000	100	1600	0.30	0.8	8500	80	1300	0.3	0.8

Depth of cut	<p style="text-align: right;">RE : Radius</p>
--------------	---

Work material		S				
		Pure titanium				
RE (mm)	Neck length LU (mm)	Revolution (min ⁻¹)	Cutting speed (m/min)	Feed rate (mm/min)	Depth of cut ap (mm)	Width of cut ae (mm)
0.5	8	27000	80	1600	0.08	0.1
0.5	10	19000	60	1200	0.08	0.1
0.5	12	19000	60	1200	0.04	0.1
0.75	10	25000	120	2000	0.13	0.2
0.75	12	21000	100	1600	0.13	0.2
1	10	32000	200	2500	0.32	0.8
1	12	29000	180	1700	0.32	0.8
1.5	12	21000	200	1600	0.48	1.2
1.5	14	21000	200	1600	0.48	1.2
1.5	16	21000	200	1600	0.48	1.2

Depth of cut	<p style="text-align: right;">RE : Radius</p>
--------------	---

- Note 1) VQ coating has less electrical conductivity; therefore an external contact type (electrically transmitted) tool setter may not work.
 When measuring the tool length, please use an internal contact type (non-electrical type) tool setter or a laser type tool setter.
- Note 2) When cutting titanium alloys, the use of water-soluble cutting fluid is effective.
- Note 3) If the depth of cut is shallow, the revolution and feed rate can be increased.

VQMHZV

End mill, Medium cut length, 3 flute.
For plunging and slotting



42°
43.5°
45°



CARBIDE

Carbon Steel, Alloy Steel, Cast Iron (<30HRC)	Tool Steel, Pre-Hardened Steel, Hardened Steel (≤45HRC)	Hardened Steel (≤55HRC)	Hardened Steel (>55HRC)	Austenitic Stainless Steel	Titanium Alloy, Heat Resistant Alloy	Copper Alloy	Aluminium Alloy
○	○			○	○	○	

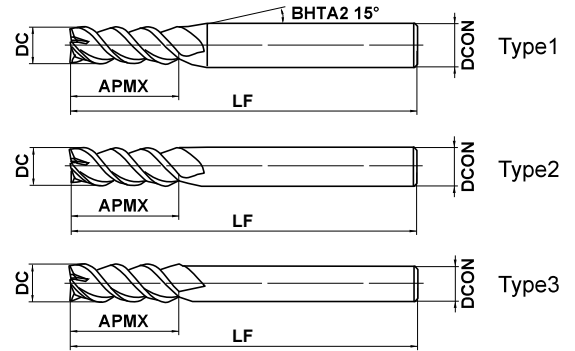

DC ≤ 12	DC > 12			
0 - 0.020	0 - 0.030			
$4 \leq DCON \leq 6$	$8 \leq DCON \leq 10$	$12 \leq DCON \leq 16$	DCON = 20	
0 - 0.008	0 - 0.009	0 - 0.011	0 - 0.013	



- 3 flute end mill for both plunging and slotting.
- Featuring irregular helix geometry for reduced chattering.

(mm)

Order Number	DC	APMX	LF	DCON	Flutes	Stock	Type
VQMHZVD0100	1	2	45	4	3	●	1
VQMHZVD0110	1.1	2.2	45	4	3	●	1
VQMHZVD0120	1.2	2.4	45	4	3	●	1
VQMHZVD0130	1.3	2.6	45	4	3	●	1
VQMHZVD0140	1.4	2.8	45	4	3	●	1
VQMHZVD0150	1.5	3	45	4	3	●	1
VQMHZVD0160	1.6	3.2	45	4	3	●	1
VQMHZVD0170	1.7	3.4	45	4	3	●	1
VQMHZVD0180	1.8	3.6	45	4	3	●	1
VQMHZVD0190	1.9	3.8	45	4	3	●	1
VQMHZVD0200	2	4	50	6	3	●	1
VQMHZVD0210	2.1	4.2	50	6	3	●	1
VQMHZVD0220	2.2	4.4	50	6	3	●	1
VQMHZVD0230	2.3	4.6	50	6	3	●	1
VQMHZVD0240	2.4	4.8	50	6	3	●	1
VQMHZVD0250	2.5	5	50	6	3	●	1
VQMHZVD0260	2.6	5.2	50	6	3	●	1
VQMHZVD0270	2.7	5.4	50	6	3	●	1
VQMHZVD0280	2.8	5.6	50	6	3	●	1
VQMHZVD0290	2.9	5.8	50	6	3	●	1
VQMHZVD0300	3	6	50	6	3	●	1
VQMHZVD0310	3.1	7	50	6	3	●	1
VQMHZVD0320	3.2	7	50	6	3	●	1
VQMHZVD0330	3.3	7	50	6	3	●	1
VQMHZVD0340	3.4	7	50	6	3	●	1
VQMHZVD0350	3.5	8	50	6	3	●	1
VQMHZVD0360	3.6	8	50	6	3	●	1
VQMHZVD0370	3.7	8	50	6	3	●	1
VQMHZVD0380	3.8	8	50	6	3	●	1
VQMHZVD0390	3.9	8	50	6	3	●	1
VQMHZVD0400	4	8	50	6	3	●	1
VQMHZVD0450	4.5	10	50	6	3	●	1
VQMHZVD0500	5	10	50	6	3	●	1
VQMHZVD0550	5.5	13	50	6	3	●	1

● : Inventory maintained.

SOLID END MILLS

SQUARE

BALL

RADIUS

TAPER

BARREL

ROUGHING

VQ END MILLS

VQMHZV

End mill, Medium cut length, For plunging and slotting, 3 flute

(mm)

Order Number	DC	APMX	LF	DCON	Flutes	Stock	Type
VQMHZVD0600	6	13	60	6	3	●	2
VQMHZVD0650	6.5	16	60	8	3	●	1
VQMHZVD0700	7	16	60	8	3	●	1
VQMHZVD0750	7.5	16	60	8	3	●	1
VQMHZVD0800	8	19	70	8	3	●	2
VQMHZVD0850	8.5	19	70	10	3	●	1
VQMHZVD0900	9	19	70	10	3	●	1
VQMHZVD0950	9.5	19	70	10	3	●	1
VQMHZVD1000	10	22	80	10	3	●	2
VQMHZVD1100	11	22	80	12	3	●	1
VQMHZVD1200	12	26	90	12	3	●	2
VQMHZVD1300	13	26	90	12	3	●	3
VQMHZVD1400	14	26	90	12	3	●	3
VQMHZVD1500	15.0	26	110	16	3	●	1
VQMHZVD1600	16	30	110	16	3	●	2
VQMHZVD2000	20	32	140	20	3	●	2

CARBIDE

—

SOLID END MILLS

SQUARE

BALL

RADIUS

TAPER

BARREL

ROUGHING

● : Inventory maintained.

RECOMMENDED CUTTING CONDITIONS

■ Side milling

When machine and work material rigidity and chip discharge properties are sufficient, please select the high efficiency cutting conditions.
When machine rigidity, work material rigidity or chip discharge properties are insufficient, please select general-purpose cutting conditions.

High efficiency cutting conditions

Work material	P					M					S									
	Carbon steel, Alloy steel, Mild steel Ck45, 41CrMo4, St44-2, Ck10					Pre-hardened steel, Alloy steel, Alloy tool steel NAK, X36CrMo17, 40CrNiMoA, X210Cr12, SKT					Austenitic, Ferritic and Martensitic stainless steels, Titanium alloys X5CrNi189, X8CrNiMo173, Ti6Al4V					Hardened stainless steels, Cobalt chromium alloy X5CrNiCuNb16-4, X7CrNiAl17-7				
Dia. DC (mm)	Cutting speed (m/min)	Revolution (min ⁻¹)	Feed rate (mm/min)	Depth of cut ap (mm)	Depth of cut ae (mm)	Cutting speed (m/min)	Revolution (min ⁻¹)	Feed rate (mm/min)	Depth of cut ap (mm)	Depth of cut ae (mm)	Cutting speed (m/min)	Revolution (min ⁻¹)	Feed rate (mm/min)	Depth of cut ap (mm)	Depth of cut ae (mm)	Cutting speed (m/min)	Revolution (min ⁻¹)	Feed rate (mm/min)	Depth of cut ap (mm)	Depth of cut ae (mm)
1	100	32000	720	1.5	0.2	80	25000	530	1.5	0.2	60	19000	430	1.5	0.2	50	16000	340	1.5	0.1
1.5	130	28000	1300	2.25	0.3	100	21000	630	2.25	0.3	85	18000	540	2.25	0.3	65	14000	420	2.25	0.15
2	150	24000	1800	3	0.6	120	19000	860	3	0.6	100	16000	620	3	0.6	75	12000	540	3	0.4
3	150	16000	1900	4.5	0.9	120	13000	940	4.5	0.9	100	11000	660	4.5	0.9	75	8000	580	4.5	0.6
4	150	12000	2000	6	1.2	120	9500	940	6	1.2	100	8000	670	6	1.2	75	6000	590	6	0.8
5	150	9500	1900	7.5	1.5	120	7600	960	7.5	1.5	100	6400	670	7.5	1.5	75	4800	600	7.5	1
6	150	8000	1900	9	1.8	120	6400	960	9	1.8	100	5300	830	9	1.8	75	4000	600	9	1.2
8	150	6000	1900	12	2.4	120	4800	1000	12	2.4	100	4000	900	12	2.4	75	3000	630	12	1.6
10	150	4800	1700	15	3	120	3800	910	15	3	100	3200	960	15	3	75	2400	580	15	2
12	150	4000	1400	18	3.6	120	3200	860	18	3.6	100	2700	890	18	3.6	75	2000	540	18	2.4
16	150	3000	1200	24	4.8	120	2400	720	24	4.8	100	2000	720	24	4.8	75	1500	450	24	3.2
20	150	2400	970	30	6	120	1900	570	30	6	100	1600	580	30	6	75	1200	360	30	4

Depth of cut

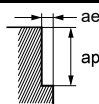

General purpose cutting conditions

Work material	P					M					S									
	Carbon steel, Alloy steel, Mild steel Ck45, 41CrMo4, St44-2, Ck10					Pre-hardened steel, Alloy steel, Alloy tool steel NAK, X36CrMo17, 40CrNiMoA, X210Cr12, SKT					Austenitic, Ferritic and Martensitic stainless steels, Titanium alloys X5CrNi189, X8CrNiMo173, Ti6Al4V					Hardened stainless steels, Cobalt chromium alloy X5CrNiCuNb16-4, X7CrNiAl17-7				
Dia. DC (mm)	Cutting speed (m/min)	Revolution (min ⁻¹)	Feed rate (mm/min)	Depth of cut ap (mm)	Depth of cut ae (mm)	Cutting speed (m/min)	Revolution (min ⁻¹)	Feed rate (mm/min)	Depth of cut ap (mm)	Depth of cut ae (mm)	Cutting speed (m/min)	Revolution (min ⁻¹)	Feed rate (mm/min)	Depth of cut ap (mm)	Depth of cut ae (mm)	Cutting speed (m/min)	Revolution (min ⁻¹)	Feed rate (mm/min)	Depth of cut ap (mm)	Depth of cut ae (mm)
1	100	32000	480	1.5	0.2	80	25000	350	1.5	0.2	60	19000	280	1.5	0.2	50	16000	220	1.5	0.1
1.5	120	25000	740	2.25	0.3	100	21000	420	2.25	0.3	80	17000	340	2.25	0.3	65	14000	280	2.25	0.15
2	120	19000	940	3	0.6	100	16000	480	3	0.6	80	13000	340	3	0.6	70	11000	330	3	0.4
3	120	13000	1000	4.5	0.9	100	11000	520	4.5	0.9	80	8500	340	4.5	0.9	70	7400	350	4.5	0.6
4	120	9500	1000	6	1.2	100	8000	520	6	1.2	80	6400	350	6	1.2	70	5600	370	6	0.8
5	120	7600	980	7.5	1.5	100	6400	530	7.5	1.5	80	5100	350	7.5	1.5	70	4500	370	7.5	1
6	120	6400	1000	9	1.8	100	5300	540	9	1.8	80	4200	400	9	1.8	70	3700	370	9	1.2
8	120	4800	1000	12	2.4	100	4000	550	12	2.4	80	3200	430	12	2.4	70	2800	390	12	1.6
10	120	3800	900	15	3	100	3200	510	15	3	80	2500	450	15	3	70	2200	350	15	2
12	120	3200	760	18	3.6	100	2700	480	18	3.6	80	2100	420	18	3.6	70	1900	340	18	2.4
16	120	2400	640	24	4.8	100	2000	400	24	4.8	80	1600	340	24	4.8	70	1400	280	24	3.2
20	120	1900	510	30	6	100	1600	320	30	6	80	1300	270	30	6	70	1100	220	30	4

Depth of cut

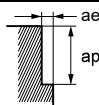

Note 1) VQ coating has less electrical conductivity; therefore an external contact type (electrically transmitted) tool setter may not work.

When measuring the tool length, please use an internal contact type (non-electrical type) tool setter or a laser type tool setter.

Note 2) Effective cutting of stainless steel, titanium alloys and heat-resistant alloys etc. can be achieved with the use of emulsion coolant.

Note 3) Chattering can still occur if the machine rigidity and clamping method are insufficient.

In these cases the feed and speed should be reduced proportionately.

Note 4) When the depth of cut is smaller than shown the revolution and feed rate can be increased.

VQ END MILLS

VQMHSV

End mill, Medium cut length, For plunging and slotting, 3 flute

CARBIDE

SOLID END MILLS

SQUARE

BALL

RADIUS

TAPER

BARREL

ROUGHING

Side milling

When machine and work material rigidity and chip discharge properties are sufficient, please select the high efficiency cutting conditions.
When machine rigidity, work material rigidity or chip discharge properties are insufficient, please select general-purpose cutting conditions.

High efficiency cutting conditions

Work material	N					S				
	Copper, Copper alloy					Heat resistant alloys Inconel718				
Dia. DC (mm)	Cutting speed (m/min)	Revolution (min ⁻¹)	Feed rate (mm/min)	Depth of cut ap (mm)	Depth of cut ae (mm)	Cutting speed (m/min)	Revolution (min ⁻¹)	Feed rate (mm/min)	Depth of cut ap (mm)	Depth of cut ae (mm)
1	120	38000	860	1.5	0.2	40	13000	160	1.5	0.05
1.5	150	32000	1400	2.25	0.3	40	8500	170	2.25	0.08
2	180	29000	2200	3	0.6	40	6400	170	3	0.2
3	180	19000	2300	4.5	0.9	40	4200	180	4.5	0.3
4	180	14000	2300	6	1.2	40	3200	180	6	0.4
5	180	11000	2300	7.5	1.5	40	2500	180	7.5	0.5
6	180	9500	2300	9	1.8	40	2100	190	9	0.6
8	180	7200	2300	12	2.4	40	1600	190	12	0.8
10	180	5700	2100	15	3	40	1300	220	15	1
12	180	4800	1700	18	3.6	40	1100	210	18	1.2
16	180	3600	1500	24	4.8	40	800	150	24	1.6
20	180	2900	1200	30	6	40	640	120	30	2

Depth of cut

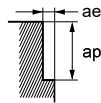

General purpose cutting conditions

Work material	N					S				
	Copper, Copper alloy					Heat resistant alloys Inconel718				
Dia. DC (mm)	Cutting speed (m/min)	Revolution (min ⁻¹)	Feed rate (mm/min)	Depth of cut ap (mm)	Depth of cut ae (mm)	Cutting speed (m/min)	Revolution (min ⁻¹)	Feed rate (mm/min)	Depth of cut ap (mm)	Depth of cut ae (mm)
1	120	38000	560	1.5	0.2	30	9500	75	1.5	0.05
1.5	140	30000	890	2.25	0.3	30	6400	82	2.25	0.07
2	140	22000	1100	3	0.6	30	4800	86	3	0.2
3	140	15000	1200	4.5	0.9	30	3200	89	4.5	0.3
4	140	11000	1200	6	1.2	30	2400	90	6	0.4
5	140	8900	1200	7.5	1.5	30	1900	90	7.5	0.5
6	140	7400	1200	9	1.8	30	1600	95	9	0.6
8	140	5600	1200	12	2.4	30	1200	95	12	0.8
10	140	4500	1100	15	3	30	950	110	15	1
12	140	3700	880	18	3.6	30	800	100	18	1.2
16	140	2800	750	24	4.8	30	600	76	24	1.6
20	140	2200	590	30	6	30	480	61	30	2

Depth of cut

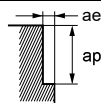

- Note 1) VQ coating is less electro conductive; therefore an external contact type (electric transmitted) tool setter may not work.
When measuring the tool length, please use an internal contact type (non-electricity type) tool setter or a laser type tool setter.
- Note 2) Effective cutting of stainless steel, titanium alloys and heat-resistant alloys etc. can be achieved with the use of emulsion.
- Note 3) Chattering can still occur if the machine rigidity and clamping method are insufficient.
In these cases the feed and speed should be reduced proportionately.
- Note 4) When the depth of cut is smaller than shown the revolution and feed rate can be increased.

Slotting

When machine and work material rigidity and chip discharge properties are sufficient, please select the high efficiency cutting conditions.
When machine rigidity, work material rigidity or chip discharge properties are insufficient, please select general-purpose cutting conditions.

High efficiency cutting conditions

Work material	P				M				S				N				S							
	Carbon steel, Alloy steel, Mild steel				Pre-hardened steel, Alloy steel, Alloy tool steel				Austenitic, Ferritic and Martensitic stainless steels, Titanium alloys				Hardened stainless steels, Cobalt chromium alloy				Copper, Copper alloy				Heat resistant alloys			
	Ck45, 41CrMo4, St44-2, Ck10				NAK, X36CrMo17, 40CrNiMoA, X210Cr12, SKT				X5CrNi189, X8CrNiMo173, Ti6Al4V				X5CrNiCuNb16-4, X7CrNiAl17-7				Inconel718							
Dia. DC (mm)	Cutting speed (m/min)	Revolution (min ⁻¹)	Feed rate (mm/min)	Depth of cut ap (mm)	Cutting speed (m/min)	Revolution (min ⁻¹)	Feed rate (mm/min)	Depth of cut ap (mm)	Cutting speed (m/min)	Revolution (min ⁻¹)	Feed rate (mm/min)	Depth of cut ap (mm)	Cutting speed (m/min)	Revolution (min ⁻¹)	Feed rate (mm/min)	Depth of cut ap (mm)	Cutting speed (m/min)	Revolution (min ⁻¹)	Feed rate (mm/min)	Depth of cut ap (mm)	Cutting speed (m/min)	Revolution (min ⁻¹)	Feed rate (mm/min)	Depth of cut ap (mm)
1	100	32000	380	0.5	80	25000	150	0.5	60	19000	100	0.5	45	14000	80	0.3	120	38000	460	0.5	30	9500	60	0.2
1.5	130	28000	590	0.75	100	21000	250	0.75	85	18000	220	0.75	60	12000	140	0.4	150	32000	670	0.75	30	6400	80	0.3
2	150	24000	940	2	120	19000	460	2	100	16000	480	2	60	9500	230	1	180	29000	1100	2	30	4800	100	0.6
3	150	16000	1100	3	120	13000	550	3	100	11000	500	3	60	6400	270	1.5	180	19000	1300	3	30	3200	120	0.9
4	150	12000	1400	4	120	9500	680	4	100	8000	530	4	60	4800	350	2	180	14000	1700	4	30	2400	130	1.2
5	150	9500	1400	5	120	7600	680	5	100	6400	540	5	60	3800	350	2.5	180	11000	1700	5	30	1900	130	1.5
6	150	8000	1400	6	120	6400	770	6	100	5300	560	6	60	3200	380	3	180	9500	1700	6	30	1600	130	1.8
8	150	6000	1300	8	120	4800	720	8	100	4000	600	8	60	2400	360	4	180	7200	1500	8	30	1200	140	2.4
10	150	4800	1200	10	120	3800	630	10	100	3200	670	10	60	1900	310	5	180	5700	1400	10	30	950	160	3
12	150	4000	960	12	120	3200	580	12	100	2700	650	12	60	1600	290	6	180	4800	1200	12	30	800	150	3.6
16	150	3000	810	12	120	2400	500	12	100	2000	480	12	60	1200	250	8	180	3600	970	12	30	600	120	4.8
20	150	2400	650	12	120	1900	400	12	100	1600	380	12	60	950	200	10	180	2900	780	12	30	480	90	6

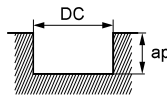

DC: Dia.

General purpose cutting conditions

Work material	P				M				S				N				S							
	Carbon steel, Alloy steel, Mild steel				Pre-hardened steel, Alloy steel, Alloy tool steel				Austenitic, Ferritic and Martensitic stainless steels, Titanium alloys				Hardened stainless steels, Cobalt chromium alloy				Copper, Copper alloy				Heat resistant alloys			
	Ck45, 41CrMo4, St44-2, Ck10				NAK, X36CrMo17, 40CrNiMoA, X210Cr12, SKT				X5CrNi189, X8CrNiMo173, Ti6Al4V				X5CrNiCuNb16-4, X7CrNiAl17-7				Inconel718							
Dia. DC (mm)	Cutting speed (m/min)	Revolution (min ⁻¹)	Feed rate (mm/min)	Depth of cut ap (mm)	Cutting speed (m/min)	Revolution (min ⁻¹)	Feed rate (mm/min)	Depth of cut ap (mm)	Cutting speed (m/min)	Revolution (min ⁻¹)	Feed rate (mm/min)	Depth of cut ap (mm)	Cutting speed (m/min)	Revolution (min ⁻¹)	Feed rate (mm/min)	Depth of cut ap (mm)	Cutting speed (m/min)	Revolution (min ⁻¹)	Feed rate (mm/min)	Depth of cut ap (mm)	Cutting speed (m/min)	Revolution (min ⁻¹)	Feed rate (mm/min)	Depth of cut ap (mm)
1	100	32000	250	0.5	80	25000	99	0.5	60	19000	80	0.5	45	14000	60	0.3	120	38000	300	0.5	25	8000	30	0.2
1.5	100	21000	290	0.75	80	17000	130	0.75	60	13000	100	0.75	50	11000	87	0.4	120	25000	350	0.75	25	5300	40	0.3
2	100	16000	410	2	80	13000	210	2	60	9500	190	2	50	8000	130	1	120	19000	490	2	25	4000	55	0.6
3	100	11000	500	3	80	8500	240	3	60	6400	190	3	50	5300	150	1.5	120	13000	590	3	25	2700	64	0.9
4	100	8000	630	4	80	6400	300	4	60	4800	210	4	50	4000	190	2	120	9500	750	4	25	2000	70	1.2
5	100	6400	630	5	80	5100	300	5	60	3800	210	5	50	3200	190	2.5	120	7600	750	5	25	1600	71	1.5
6	100	5300	630	6	80	4200	330	6	60	3200	220	6	50	2700	210	3	120	6400	760	6	25	1300	72	1.8
8	100	4000	550	8	80	3200	320	8	60	2400	240	8	50	2000	200	4	120	4800	670	8	25	990	78	2.4
10	100	3200	510	10	80	2500	270	10	60	1900	260	10	50	1600	170	5	120	3800	600	10	25	800	89	3
12	100	2700	430	12	80	2100	250	12	60	1600	250	12	50	1300	150	6	120	3200	510	12	25	660	84	3.6
16	100	2000	360	12	80	1600	220	12	60	1200	190	12	50	990	140	8	120	2400	430	12	25	500	63	4.8
20	100	1600	290	12	80	1300	180	12	60	950	150	12	50	800	110	10	120	1900	340	12	25	400	50	6

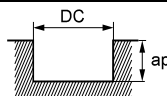

DC: Dia.

- Note 1) VQ coating has less electrical conductivity; therefore an external contact type (electrically transmitted) tool setter may not work. When measuring the tool length, please use an internal contact type (non-electrical type) tool setter or a laser type tool setter.
- Note 2) Effective cutting of stainless steel, titanium alloys and heat-resistant alloys etc, can be achieved with the use of emulsion coolant.
- Note 3) Chattering can still occur if the machine rigidity and clamping method are insufficient. In these cases the feed and speed should be reduced proportionately.
- Note 4) When the depth of cut is smaller than shown the revolution and feed rate can be increased.

VQ END MILLS

VQMHSV

End mill, Medium cut length, For plunging and slotting, 3 flute

CARBIDE

SOLID END MILLS

SQUARE

BALL

RADIUS

TAPER

BARREL

ROUGHING

Plunging

When machine and work material rigidity and chip discharge properties are sufficient, please select the high efficiency cutting conditions.

When machine rigidity, work material rigidity or chip discharge properties are insufficient, please select general-purpose cutting conditions.

High efficiency cutting conditions

Work material	P					M					S					N									
	Carbon steel, Alloy steel, Mild steel					Pre-hardened steel, Alloy steel, Alloy tool steel					Austenitic, Ferritic and Martensitic stainless steels, Titanium alloys					Hardened stainless steels, Cobalt chromium alloy					Copper, Copper alloy				
	Ck45, 41CrMo4, St44-2, Ck10					NAK, X36CrMo17, 40CrNiMoA, X210Cr12, SKT					X5CrNi189, X8CrNiMo173, Ti6Al4V					X5CrNiCuNb16-4, X7CrNiAl17-7									
Dia. DC (mm)	Cutting speed (mm/min)	Revolution (min ⁻¹)	Feed rate (mm/min)	Hole Depth ap (mm)	Step (mm)	Cutting speed (mm/min)	Revolution (min ⁻¹)	Feed rate (mm/min)	Hole Depth ap (mm)	Step (mm)	Cutting speed (mm/min)	Revolution (min ⁻¹)	Feed rate (mm/min)	Hole Depth ap (mm)	Step (mm)	Cutting speed (mm/min)	Revolution (min ⁻¹)	Feed rate (mm/min)	Hole Depth ap (mm)	Step (mm)	Cutting speed (mm/min)	Revolution (min ⁻¹)	Feed rate (mm/min)	Hole Depth ap (mm)	Step (mm)
1	65	20000	160	0.5	0.1	50	16000	100	0.5	0.1	50	16000	50	0.5	0.05	30	9500	30	0.5	0.05	75	24000	190	0.5	0.1
1.5	85	18000	270	0.75	0.3	60	13000	120	0.75	0.3	60	13000	80	0.75	0.1	35	7400	40	0.75	0.1	100	21000	320	0.75	0.3
2	100	16000	480	2	0.5	70	11000	200	2	0.4	60	9500	90	1	0.15	40	6400	60	1	0.1	120	19000	570	2	0.5
3	100	11000	660	3	1	70	7400	270	3	0.6	60	6400	100	1.5	0.2	40	4200	60	1.5	0.2	120	13000	780	3	1.0
4	100	8000	800	4	2	70	5600	340	4	0.8	60	4800	100	2	0.4	40	3200	60	2	0.4	120	9500	950	4	2
5	100	6400	960	5	2.5	70	4500	410	5	1	60	3800	100	2.5	0.5	40	2500	60	2.5	0.5	120	7600	1100	5	2.5
6	100	5300	950	6	3	70	3700	440	6	1.2	60	3200	100	3	0.6	40	2100	60	3	0.6	120	6400	1200	6	3
8	100	4000	720	8	4	70	2800	340	8	1.6	60	2400	70	4	0.6	40	1600	50	4	0.6	120	4800	860	8	4
10	100	3200	580	10	5	70	2200	260	10	2.5	60	1900	60	5	0.6	40	1300	40	5	0.6	120	3800	680	10	5
12	100	2700	490	12	5	70	1900	230	12	3	60	1600	50	6	0.6	40	1100	30	6	0.6	120	3200	580	12	5
16	100	2000	360	16	5	70	1400	170	16	4	60	1200	40	8	0.6	40	800	20	8	0.6	120	2400	430	16	5
20	100	1600	290	20	5	70	1100	130	20	5	60	950	30	10	0.6	40	640	20	10	0.6	120	1900	340	20	5

General purpose cutting conditions

Work material	P					M					S					N									
	Carbon steel, Alloy steel, Mild steel					Pre-hardened steel, Alloy steel, Alloy tool steel					Austenitic, Ferritic and Martensitic stainless steels, Titanium alloys					Hardened stainless steels, Cobalt chromium alloy					Copper, Copper alloy				
	Ck45, 41CrMo4, St44-2, Ck10					NAK, X36CrMo17, 40CrNiMoA, X210Cr12, SKT					X5CrNi189, X8CrNiMo173, Ti6Al4V					X5CrNiCuNb16-4, X7CrNiAl17-7									
Dia. DC (mm)	Cutting speed (mm/min)	Revolution (min ⁻¹)	Feed rate (mm/min)	Hole Depth ap (mm)	Step (mm)	Cutting speed (mm/min)	Revolution (min ⁻¹)	Feed rate (mm/min)	Hole Depth ap (mm)	Step (mm)	Cutting speed (mm/min)	Revolution (min ⁻¹)	Feed rate (mm/min)	Hole Depth ap (mm)	Step (mm)	Cutting speed (mm/min)	Revolution (min ⁻¹)	Feed rate (mm/min)	Hole Depth ap (mm)	Step (mm)	Cutting speed (mm/min)	Revolution (min ⁻¹)	Feed rate (mm/min)	Hole Depth ap (mm)	Step (mm)
1	65	20000	160	0.5	0.05	50	16000	100	0.5	0.05	50	16000	50	0.5	0.05	30	9500	30	0.5	0.05	75	24000	190	0.5	0.05
1.5	85	18000	270	0.75	0.15	60	13000	120	0.75	0.1	60	13000	80	0.75	0.05	35	7400	40	0.75	0.05	100	21000	320	0.75	0.15
2	100	16000	480	2	0.25	70	11000	200	2	0.2	60	9500	90	1	0.05	40	6400	60	1	0.05	120	19000	570	2	0.25
3	100	11000	660	3	0.3	70	7400	270	3	0.3	60	6400	100	1.5	0.1	40	4200	60	1.5	0.1	120	13000	780	3	0.3
4	100	8000	800	4	0.4	70	5600	340	4	0.4	60	4800	100	2	0.2	40	3200	60	2	0.2	120	9500	950	4	0.4
5	100	6400	960	5	0.5	70	4500	410	5	0.5	60	3800	100	2.5	0.25	40	2500	60	2.5	0.25	120	7600	1100	5	0.5
6	100	5300	950	6	0.6	70	3700	440	6	0.6	60	3200	100	3	0.3	40	2100	60	3	0.3	120	6400	1200	6	0.6
8	100	4000	720	8	0.7	70	2800	340	8	0.7	60	2400	70	4	0.3	40	1600	50	4	0.3	120	4800	860	8	0.7
10	100	3200	580	10	0.75	70	2200	260	10	0.75	60	1900	60	5	0.3	40	1300	40	5	0.3	120	3800	680	10	0.75
12	100	2700	490	12	0.75	70	1900	230	12	0.75	60	1600	50	6	0.3	40	1100	30	6	0.3	120	3200	580	12	0.75
16	100	2000	360	16	0.75	70	1400	170	16	0.75	60	1200	40	8	0.3	40	800	20	8	0.3	120	2400	430	16	0.75
20	100	1600	290	20	0.75	70	1100	130	20	0.75	60	950	30	10	0.3	40	640	20	10	0.3	120	1900	340	20	0.75

Note 1) VQ coating has less electrical conductivity; therefore an external contact type (electrically transmitted) tool setter may not work.

When measuring the tool length, please use an internal contact type (non-electrical type) tool setter or a laser type tool setter.

Note 2) Effective cutting of stainless steel, titanium alloys and heat-resistant alloys etc. can be achieved with the use of emulsion coolant.

Note 3) Chattering can still occur if the machine rigidity and clamping method are insufficient.

In these cases the feed and speed should be reduced proportionately.

VQMZHVOH

End mill, Medium cut length, for plunging and slotting, 3 flute.
With internal through coolant holes.



42°
43.5°
45°



CARBIDE

Carbon Steel, Alloy Steel, Cast Iron (<30HRC)	Tool Steel, Pre-Hardened Steel, Hardened Steel (≤45HRC)	Hardened Steel (≤55HRC)	Hardened Steel (>55HRC)	Austenitic Stainless Steel	Titanium Alloy, Heat Resistant Alloy	Copper Alloy	Aluminium Alloy
○	○			○	○	○	

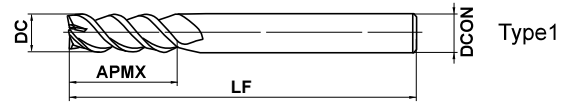

	DC ≤ 12	DC = 16			
	$\begin{matrix} 0 \\ -0.020 \end{matrix}$	$\begin{matrix} 0 \\ -0.030 \end{matrix}$			
	D CON = 6	8 ≤ D CON ≤ 10	12 ≤ D CON ≤ 16		
	$\begin{matrix} 0 \\ -0.008 \end{matrix}$	$\begin{matrix} 0 \\ -0.009 \end{matrix}$	$\begin{matrix} 0 \\ -0.011 \end{matrix}$		

- 3 flute end mill for both plunging and slotting.
- Through coolant holes for high performance plunging and pocketing.

(mm)

Order Number	DC	APMX	LF	D CON	Flutes	Stock	Type
VQMZHVOHD0600	6	13	60	6	3	●	1
VQMZHVOHD0800	8	19	70	8	3	●	1
VQMZHVOHD1000	10	22	80	10	3	●	1
VQMZHVOHD1200	12	26	90	12	3	●	1
VQMZHVOHD1600	16	30	110	16	3	●	1

SOLID END MILLS

SQUARE

BALL

RADIUS

TAPER

BARREL

ROUGHING

● : Inventory maintained.

VQ END MILLS

VQMhZVOH

End mill, Medium cut length, For plunging and slotting, 3 flute. With internal through coolant holes

CARBIDE

RECOMMENDED CUTTING CONDITIONS

Slotting

When machine and work material rigidity and chip discharge properties are sufficient, please select the high efficiency cutting conditions.
When machine rigidity, work material rigidity or chip discharge properties are insufficient, please select general-purpose cutting conditions.

High efficiency cutting conditions

Work material	P				M				S				N				S							
	Carbon steel, Alloy steel, Mild steel Ck45, 41CrMo4, St44-2, Ck10				Pre-hardened steel, Alloy steel, Alloy tool steel NAK, X36CrMo17, 40CrNiMoA, X210Cr12, SKT				Austenitic, Ferritic and Martensitic stainless steels, Titanium alloys X5CrNi189, X8CrNiMo173, Ti6Al4V				Hardened stainless steels, Cobalt chromium alloy X5CrNiCuNb16-4, X7CrNiAl17-7				Copper, Copper alloy				Heat resistant alloys Inconel718			
Dia. DC (mm)	Cutting speed (m/min)	Revolution (mir ⁻¹)	Feed rate (mm/min)	Depth of cut ap (mm)	Cutting speed (m/min)	Revolution (mir ⁻¹)	Feed rate (mm/min)	Depth of cut ap (mm)	Cutting speed (m/min)	Revolution (mir ⁻¹)	Feed rate (mm/min)	Depth of cut ap (mm)	Cutting speed (m/min)	Revolution (mir ⁻¹)	Feed rate (mm/min)	Depth of cut ap (mm)	Cutting speed (m/min)	Revolution (mir ⁻¹)	Feed rate (mm/min)	Depth of cut ap (mm)	Cutting speed (m/min)	Revolution (mir ⁻¹)	Feed rate (mm/min)	Depth of cut ap (mm)
6	150	8000	1400	6	120	6400	770	6	100	5300	560	6	60	3200	380	3	180	9500	1700	6	30	1600	130	1.8
8	150	6000	1300	8	120	4800	720	8	100	4000	600	8	60	2400	360	4	180	7200	1500	8	30	1200	140	2.4
10	150	4800	1200	10	120	3800	630	10	100	3200	670	10	60	1900	310	5	180	5700	1400	10	30	950	160	3
12	150	4000	960	12	120	3200	580	12	100	2700	650	12	60	1600	290	6	180	4800	1200	12	30	800	150	3.6
16	150	3000	810	12	120	2400	500	12	100	2000	480	12	60	1200	250	8	180	3600	970	12	30	600	120	4.8

Depth of cut

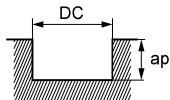

DC: Dia.

General purpose cutting conditions

Work material	P				M				S				N				S							
	Carbon steel, Alloy steel, Mild steel Ck45, 41CrMo4, St44-2, Ck10				Pre-hardened steel, Alloy steel, Alloy tool steel NAK, X36CrMo17, 40CrNiMoA, X210Cr12, SKT				Austenitic, Ferritic and Martensitic stainless steels, Titanium alloys X5CrNi189, X8CrNiMo173, Ti6Al4V				Hardened stainless steels, Cobalt chromium alloy X5CrNiCuNb16-4, X7CrNiAl17-7				Copper, Copper alloy				Heat resistant alloys Inconel718			
Dia. DC (mm)	Cutting speed (m/min)	Revolution (mir ⁻¹)	Feed rate (mm/min)	Depth of cut ap (mm)	Cutting speed (m/min)	Revolution (mir ⁻¹)	Feed rate (mm/min)	Depth of cut ap (mm)	Cutting speed (m/min)	Revolution (mir ⁻¹)	Feed rate (mm/min)	Depth of cut ap (mm)	Cutting speed (m/min)	Revolution (mir ⁻¹)	Feed rate (mm/min)	Depth of cut ap (mm)	Cutting speed (m/min)	Revolution (mir ⁻¹)	Feed rate (mm/min)	Depth of cut ap (mm)	Cutting speed (m/min)	Revolution (mir ⁻¹)	Feed rate (mm/min)	Depth of cut ap (mm)
6	100	5300	630	6	80	4200	330	6	60	3200	220	6	50	2700	210	3	120	6400	760	6	25	1300	72	1.8
8	100	4000	550	8	80	3200	320	8	60	2400	240	8	50	2000	200	4	120	4800	670	8	25	990	78	2.4
10	100	3200	510	10	80	2500	270	10	60	1900	260	10	50	1600	170	5	120	3800	600	10	25	800	89	3
12	100	2700	430	12	80	2100	250	12	60	1600	250	12	50	1300	150	6	120	3200	510	12	25	660	84	3.6
16	100	2000	360	12	80	1600	220	12	60	1200	190	12	50	990	140	8	120	2400	430	12	25	500	63	4.8

Depth of cut

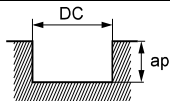

DC: Dia.

Note 1) VQ coating has less electrical conductivity; therefore an external contact type (electrically transmitted) tool setter may not work.

When measuring the tool length, please use an internal contact type (non-electrical type) tool setter or a laser type tool setter.

Note 2) Effective cutting of stainless steel, titanium alloys and heat-resistant alloys etc. can be achieved with the use of emulsion coolant.

Note 3) Chattering can still occur if the machine rigidity and clamping method are insufficient.

In these cases the feed and speed should be reduced proportionately.

Note 4) When the depth of cut is smaller than shown the revolution and feed rate can be increased.

SOLID END MILLS

SQUARE

BALL

RADIUS

TAPER

BARREL

ROUGHING

Plunging

When machine and work material rigidity and chip discharge properties are sufficient, please select the high efficiency cutting conditions.
When machine rigidity, work material rigidity or chip discharge properties are insufficient, please select general-purpose cutting conditions.

High efficiency cutting conditions

Work material	P					M					S					N									
	Carbon steel, Alloy steel, Mild steel Ck45, 41CrMo4, St44-2, Ck10					Pre-hardened steel, Alloy steel, Alloy tool steel NAK, X36CrMo17, 40CrNiMoA, X210Cr12, SKT					Austenitic, Ferritic and Martensitic stainless steels, Titanium alloys X5CrNi189, X8CrNiMo173, Ti6Al4V					Hardened stainless steels, Cobalt chromium alloy X5CrNiCuNb16-4, X7CrNiAl17-7					Copper, Copper alloy				
Dia. DC (mm)	Cutting speed (m/min)	Revolution (min ⁻¹)	Feed rate (mm/min)	Hole Depth ap (mm)	Step (mm)	Cutting speed (m/min)	Revolution (min ⁻¹)	Feed rate (mm/min)	Hole Depth ap (mm)	Step (mm)	Cutting speed (m/min)	Revolution (min ⁻¹)	Feed rate (mm/min)	Hole Depth ap (mm)	Step (mm)	Cutting speed (m/min)	Revolution (min ⁻¹)	Feed rate (mm/min)	Hole Depth ap (mm)	Step (mm)	Cutting speed (m/min)	Revolution (min ⁻¹)	Feed rate (mm/min)	Hole Depth ap (mm)	Step (mm)
6	100	5300	950	9	3	70	3700	440	9	1.2	60	3200	100	6	0.6	40	2100	60	6	0.6	120	6400	1200	9	3
8	100	4000	720	12	4	70	2800	340	12	1.6	60	2400	70	8	0.6	40	1600	50	8	0.6	120	4800	860	12	4
10	100	3200	580	15	5	70	2200	260	15	2.5	60	1900	60	10	0.6	40	1300	40	10	0.6	120	3800	680	15	5
12	100	2700	490	18	5	70	1900	230	18	3	60	1600	50	12	0.6	40	1100	30	12	0.6	120	3200	580	18	5
16	100	2000	360	24	5	70	1400	170	24	4	60	1200	40	16	0.6	40	800	20	16	0.6	120	2400	430	24	5

General purpose cutting conditions

Work material	P					M					S					N									
	Carbon steel, Alloy steel, Mild steel Ck45, 41CrMo4, St44-2, Ck10					Pre-hardened steel, Alloy steel, Alloy tool steel NAK, X36CrMo17, 40CrNiMoA, X210Cr12, SKT					Austenitic, Ferritic and Martensitic stainless steels, Titanium alloys X5CrNi189, X8CrNiMo173, Ti6Al4V					Hardened stainless steels, Cobalt chromium alloy X5CrNiCuNb16-4, X7CrNiAl17-7					Copper, Copper alloy				
Dia. DC (mm)	Cutting speed (m/min)	Revolution (min ⁻¹)	Feed rate (mm/min)	Hole Depth ap (mm)	Step (mm)	Cutting speed (m/min)	Revolution (min ⁻¹)	Feed rate (mm/min)	Hole Depth ap (mm)	Step (mm)	Cutting speed (m/min)	Revolution (min ⁻¹)	Feed rate (mm/min)	Hole Depth ap (mm)	Step (mm)	Cutting speed (m/min)	Revolution (min ⁻¹)	Feed rate (mm/min)	Hole Depth ap (mm)	Step (mm)	Cutting speed (m/min)	Revolution (min ⁻¹)	Feed rate (mm/min)	Hole Depth ap (mm)	Step (mm)
6	100	5300	950	9	0.6	70	3700	440	9	0.6	60	3200	100	6	0.3	40	2100	60	6	0.3	120	6400	1200	9	0.6
8	100	4000	720	12	0.7	70	2800	340	12	0.7	60	2400	70	8	0.3	40	1600	50	8	0.3	120	4800	860	12	0.7
10	100	3200	580	15	0.75	70	2200	260	15	0.75	60	1900	60	10	0.3	40	1300	40	10	0.3	120	3800	680	15	0.75
12	100	2700	490	18	0.75	70	1900	230	18	0.75	60	1600	50	12	0.3	40	1100	30	12	0.3	120	3200	580	18	0.75
16	100	2000	360	24	0.75	70	1400	170	24	0.75	60	1200	40	16	0.3	40	800	20	16	0.3	120	2400	430	24	0.75

Note 1) VQ coating has less electrical conductivity; therefore an external contact type (electrically transmitted) tool setter may not work.

When measuring the tool length, please use an internal contact type (non-electrical type) tool setter or a laser type tool setter.

Note 2) Effective cutting of stainless steel, titanium alloys and heat-resistant alloys etc. can be achieved with the use of emulsion coolant.

Note 3) Chattering can still occur if the machine rigidity and clamping method are insufficient.

In these cases the feed and speed should be reduced proportionately.

SOLID END MILLS

SQUARE

BALL

RADIUS

TAPER

BARREL

ROUGHING

VQ END MILLS

VQMHV

End mill, Medium cut length, Irregular helix, 4 flute



Carbon Steel, Alloy Steel, Cast Iron (<30HRC)	Tool Steel, Pre-Hardened Steel, Hardened Steel (≤45HRC)	Hardened Steel (≤55HRC)	Hardened Steel (>55HRC)	Austenitic Stainless Steel	Titanium Alloy, Heat Resistant Alloy	Copper Alloy	Aluminium Alloy
○	○			○	○	○	

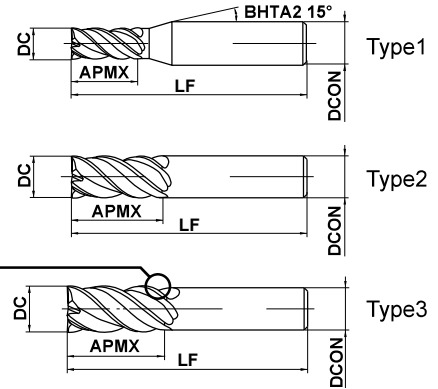

DC ≤ 12	DC > 12			
0 - 0.020	0 - 0.030			
4 ≤ DCON ≤ 6	8 ≤ DCON ≤ 10	12 ≤ DCON ≤ 16	20 ≤ DCON ≤ 25	
0 - 0.008	0 - 0.009	0 - 0.011	0 - 0.013	

● VQ vibration control end mills for reduced chattering, enabling a stable performance on difficult-to-cut materials and long overhang applications.

(mm)

Order Number	DC	APMX	LF	DCON	Flutes	Stock	Type
VQMHVD0100	1	2	45	4	4	●	1
VQMHVD0150	1.5	3	45	4	4	●	1
VQMHVD0200	2	4	45	4	4	●	1
VQMHVD0250	2.5	5	45	4	4	●	1
VQMHVD0300	3	8	45	6	4	●	1
VQMHVD0350	3.5	8	45	6	4	●	1
VQMHVD0400	4	11	45	6	4	●	1
VQMHVD0500	5	13	50	6	4	●	1
VQMHVD0600	6	13	50	6	4	●	2
VQMHVD0700	7	19	60	8	4	●	1
VQMHVD0800	8	19	60	8	4	●	2
VQMHVD0900	9	22	70	10	4	●	1
VQMHVD0900S08	9	22	75	8	4	●	3
VQMHVD1000	10	22	70	10	4	●	2
VQMHVD1000S08	10	22	100	8	4	●	3
VQMHVD1100	11	26	75	12	4	●	1
VQMHVD1100S10	11	26	100	10	4	●	3
VQMHVD1200	12	26	75	12	4	●	2
VQMHVD1200S10	12	26	110	10	4	●	3
VQMHVD1300	13	26	75	12	4	●	3
VQMHVD1300S12	13	26	110	12	4	●	3
VQMHVD1400	14	30	90	16	4	●	1
VQMHVD1400S12	14	32	130	12	4	●	3
VQMHVD1600	16	35	90	16	4	●	2
VQMHVD1800	18	40	100	16	4	●	3
VQMHVD1800S16	18	42	150	16	4	●	3
VQMHVD2000	20	45	110	20	4	●	2
VQMHVD2500	25	55	125	25	4	●	2

● : Inventory maintained.

SOLID END MILLS

SQUARE

BALL

RADIUS

TAPER

BARREL

ROUGHING

RECOMMENDED CUTTING CONDITIONS

■ Side milling

When machine and work material rigidity and chip discharge properties are sufficient, please select the high efficiency cutting conditions.
When machine rigidity, work material rigidity or chip discharge properties are insufficient, please select general-purpose cutting conditions.

High efficiency cutting conditions

Work material	P					M					S									
	Carbon steel, Alloy steel, Mild steel Ck45, 41CrMo4, St44-2, Ck10					Pre-hardened steel, Alloy steel, Alloy tool steel NAK, X36CrMo17, 40CrNiMoA, X210Cr12, SKT					Austenitic, Ferritic and Martensitic stainless steels, Titanium alloys X5CrNi189, X8CrNiMo173, Ti6Al4V					Hardened stainless steels, Cobalt chromium alloy X5CrNiCuNb16-4, X7CrNiAl17-7				
Dia. DC (mm)	Cutting speed (m/min)	Revolution (min ⁻¹)	Feed rate (mm/min)	Depth of cut ap (mm)	Depth of cut ae (mm)	Cutting speed (m/min)	Revolution (min ⁻¹)	Feed rate (mm/min)	Depth of cut ap (mm)	Depth of cut ae (mm)	Cutting speed (m/min)	Revolution (min ⁻¹)	Feed rate (mm/min)	Depth of cut ap (mm)	Depth of cut ae (mm)	Cutting speed (m/min)	Revolution (min ⁻¹)	Feed rate (mm/min)	Depth of cut ap (mm)	Depth of cut ae (mm)
1	130	40000	1800	1.5	0.3	120	38000	910	1.5	0.3	80	25000	500	1.5	0.2	75	24000	580	1.5	0.2
2	150	24000	2400	3	0.6	120	19000	1100	3	0.6	100	16000	830	3	0.6	75	12000	720	3	0.4
3	150	16000	2600	4.5	0.9	120	13000	1200	4.5	0.9	100	11000	880	4.5	0.9	75	8000	770	4.5	0.6
4	150	12000	2600	6	1.2	120	9500	1300	6	1.2	100	8000	900	6	1.2	75	6000	790	6	0.8
5	150	9500	2600	7.5	1.5	120	7600	1300	7.5	1.5	100	6400	900	7.5	1.5	75	4800	810	7.5	1
6	150	8000	2600	9	1.8	120	6400	1300	9	1.8	100	5300	1100	9	1.8	75	4000	810	9	1.2
8	150	6000	2500	12	2.4	120	4800	1300	12	2.4	100	4000	1200	12	2.4	75	3000	840	12	1.6
10	150	4800	2300	15	3	120	3800	1200	15	3	100	3200	1300	15	3	75	2400	770	15	2
12	150	4000	1900	18	3.6	120	3200	1200	18	3.6	100	2700	1200	18	3.6	75	2000	720	18	2.4
16	150	3000	1600	24	4.8	120	2400	960	24	4.8	100	2000	960	24	4.8	75	1500	600	24	3.2
20	150	2400	1300	30	6	120	1900	760	30	6	100	1600	770	30	6	75	1200	480	30	4
25	150	1900	1100	37.5	7.5	120	1500	600	37.5	7.5	100	1300	620	37.5	7.5	75	950	380	37.5	5

Depth of cut

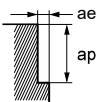

General purpose cutting conditions

Work material	P					M					S									
	Carbon steel, Alloy steel, Mild steel Ck45, 41CrMo4, St44-2, Ck10					Pre-hardened steel, Alloy steel, Alloy tool steel NAK, X36CrMo17, 40CrNiMoA, X210Cr12, SKT					Austenitic, Ferritic and Martensitic stainless steels, Titanium alloys X5CrNi189, X8CrNiMo173, Ti6Al4V					Hardened stainless steels, Cobalt chromium alloy X5CrNiCuNb16-4, X7CrNiAl17-7				
Dia. DC (mm)	Cutting speed (m/min)	Revolution (min ⁻¹)	Feed rate (mm/min)	Depth of cut ap (mm)	Depth of cut ae (mm)	Cutting speed (m/min)	Revolution (min ⁻¹)	Feed rate (mm/min)	Depth of cut ap (mm)	Depth of cut ae (mm)	Cutting speed (m/min)	Revolution (min ⁻¹)	Feed rate (mm/min)	Depth of cut ap (mm)	Depth of cut ae (mm)	Cutting speed (m/min)	Revolution (min ⁻¹)	Feed rate (mm/min)	Depth of cut ap (mm)	Depth of cut ae (mm)
1	120	38000	1000	1.5	0.3	100	32000	560	1.5	0.3	80	25000	400	0.75	0.1	70	22000	390	1.5	0.2
2	120	19000	1300	3	0.6	100	16000	630	3	0.6	80	13000	450	1.5	0.2	70	11000	440	3	0.4
3	120	13000	1400	4.5	0.9	100	11000	700	4.5	0.9	80	8500	450	2.2	0.3	70	7400	470	4.5	0.6
4	120	9500	1400	6	1.2	100	8000	700	6	1.2	80	6400	470	3	0.6	70	5600	490	6	0.8
5	120	7600	1400	7.5	1.5	100	6400	710	7.5	1.5	80	5100	470	4.5	0.9	70	4500	500	7.5	1
6	120	6400	1400	9	1.8	100	5300	710	9	1.8	80	4200	580	6	1.2	70	3700	500	9	1.2
8	120	4800	1300	12	2.4	100	4000	740	12	2.4	80	3200	630	7.5	1.5	70	2800	520	12	1.6
10	120	3800	1200	15	3	100	3200	680	15	3	80	2500	660	9	1.8	70	2200	460	15	2
12	120	3200	1000	18	3.6	100	2700	640	18	3.6	80	2100	610	12	2.4	70	1900	450	18	2.4
16	120	2400	860	24	4.8	100	2000	530	24	4.8	80	1600	510	15	3	70	1400	370	24	3.2
20	120	1900	680	30	6	100	1600	420	30	6	80	1300	410	18	3.6	70	1100	290	30	4
25	120	1500	390	37.5	7.5	100	1300	340	37.5	7.5	80	1000	210	24	4.8	70	890	230	37.5	5

Depth of cut

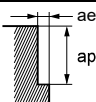

Note 1) VQ coating has less electrical conductivity; therefore an external contact type (electrically transmitted) tool setter may not work.

When measuring the tool length, please use an internal contact type (non-electrical type) tool setter or a laser type tool setter.

Note 2) Effective cutting of stainless steel, titanium alloys and heat-resistant alloys etc. can be achieved with the use of emulsion coolant.

Note 3) Chattering can still occur if the machine rigidity and clamping method are insufficient.

In these cases the feed and speed should be reduced proportionately.

Note 4) When the depth of cut is smaller than shown the revolution and feed rate can be increased.

VQ END MILLS

VQMHV

End mill, Medium cut length, Irregular helix, 4 flute

CARBIDE

SOLID END MILLS

SQUARE

BALL

RADIUS

TAPER

BARREL

ROUGHING

Side milling

When machine and work material rigidity and chip discharge properties are sufficient, please select the high efficiency cutting conditions.
When machine rigidity, work material rigidity or chip discharge properties are insufficient, please select general-purpose cutting conditions.

High efficiency cutting conditions

Work material	N					S				
	Copper, Copper alloy					Heat resistant alloys Inconel718				
Dia. DC (mm)	Cutting speed (m/min)	Revolution (min ⁻¹)	Feed rate (mm/min)	Depth of cut ap (mm)	Depth of cut ae (mm)	Cutting speed (m/min)	Revolution (min ⁻¹)	Feed rate (mm/min)	Depth of cut ap (mm)	Depth of cut ae (mm)
1	130	40000	1800	1.5	0.3	40	1300	210	1.5	0.1
2	180	29000	2900	3	0.6	40	6400	230	3	0.2
3	180	19000	3000	4.5	0.9	40	4200	240	4.5	0.3
4	180	14000	3000	6	1.2	40	3200	240	6	0.4
5	180	11000	3000	7.5	1.5	40	2500	240	7.5	0.5
6	180	9500	3000	9	1.8	40	2100	250	9	0.6
8	180	7200	3000	12	2.4	40	1600	260	12	0.8
10	180	5700	2700	15	3	40	1300	290	15	1
12	180	4800	2300	18	3.6	40	1100	280	18	1.2
16	180	3600	1900	24	4.8	40	800	200	24	1.6
20	180	2900	1600	30	6	40	640	160	30	2
25	180	2300	1300	37.5	7.5	40	510	130	37.5	2.5

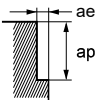
Depth of cut 

General purpose cutting conditions

Work material	N					S				
	Copper, Copper alloy					Heat resistant alloys Inconel718				
Dia. DC (mm)	Cutting speed (m/min)	Revolution (min ⁻¹)	Feed rate (mm/min)	Depth of cut ap (mm)	Depth of cut ae (mm)	Cutting speed (m/min)	Revolution (min ⁻¹)	Feed rate (mm/min)	Depth of cut ap (mm)	Depth of cut ae (mm)
1	130	40000	1300	1.5	0.3	30	9600	92	1.5	0.1
2	140	22000	1500	3	0.6	30	4800	110	3	0.2
3	140	15000	1600	4.5	0.9	30	3200	120	4.5	0.3
4	140	11000	1600	6	1.2	30	2400	120	6	0.4
5	140	8900	1600	7.5	1.5	30	1900	120	7.5	0.5
6	140	7400	1600	9	1.8	30	1600	130	9	0.6
8	140	5600	1600	12	2.4	30	1200	130	12	0.8
10	140	4500	1400	15	3	30	950	140	15	1
12	140	3700	1200	18	3.6	30	800	140	18	1.2
16	140	2800	1000	24	4.8	30	600	100	24	1.6
20	140	2200	780	30	6	30	480	81	30	2
25	140	1800	670	37.5	7.5	30	380	64	37.5	2.5

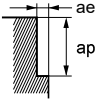
Depth of cut 

- Note 1) VQ coating has less electrical conductivity; therefore an external contact type (electrically transmitted) tool setter may not work.
When measuring the tool length, please use an internal contact type (non-electrical type) tool setter or a laser type tool setter.
- Note 2) Effective cutting of stainless steel, titanium alloys and heat-resistant alloys etc. can be achieved with the use of emulsion coolant.
- Note 3) Chattering can still occur if the machine rigidity and clamping method are insufficient.
In these cases the feed and speed should be reduced proportionately.
- Note 4) When the depth of cut is smaller than shown the revolution and feed rate can be increased.

■ Slotting

When machine and work material rigidity and chip discharge properties are sufficient, please select the high efficiency cutting conditions.
When machine rigidity, work material rigidity or chip discharge properties are insufficient, please select general-purpose cutting conditions.

High efficiency cutting conditions

Work material	P				M				S				M				S				N				S			
	Carbon steel, Alloy steel, Mild steel				Pre-hardened steel, Alloy steel, Alloy tool steel				Austenitic, Ferritic and Martensitic stainless steels, Titanium alloys				Hardened stainless steels, Cobalt chromium alloy				Copper, Copper alloy				Heat resistant alloys							
	Ck45, 41CrMo4, St44-2, Ck10				NAK, X36CrMo17, 40CrNiMoA, X210Cr12, SKT				X5CrNi189, X8CrNiMo173, Ti6Al4V				X5CrNiCuNb16-4, X7CrNiAl17-7				Inconel718											
Dia. DC (mm)	Cutting speed (m/min)	Revolution (mir ⁻¹)	Feed rate (mm/min)	Depth of cut ap (mm)	Cutting speed (m/min)	Revolution (mir ⁻¹)	Feed rate (mm/min)	Depth of cut ap (mm)	Cutting speed (m/min)	Revolution (mir ⁻¹)	Feed rate (mm/min)	Depth of cut ap (mm)	Cutting speed (m/min)	Revolution (mir ⁻¹)	Feed rate (mm/min)	Depth of cut ap (mm)	Cutting speed (m/min)	Revolution (mir ⁻¹)	Feed rate (mm/min)	Depth of cut ap (mm)	Cutting speed (m/min)	Revolution (mir ⁻¹)	Feed rate (mm/min)	Depth of cut ap (mm)				
2	150	24000	1200	2	120	19000	610	2	100	16000	640	2	60	9500	300	1	180	29000	1500	2	30	4800	130	0.6				
3	150	16000	1500	3	120	13000	730	3	100	11000	660	3	60	6400	360	1.5	180	19000	1700	3	30	3200	150	0.9				
4	150	12000	1900	4	120	9500	910	4	100	8000	700	4	60	4800	460	2	180	14000	2200	4	30	2400	170	1.2				
5	150	9500	1900	5	120	7600	910	5	100	6400	720	5	60	3800	460	2.5	180	11000	2200	5	30	1900	170	1.5				
6	150	8000	1900	6	120	6400	1000	6	100	5300	740	6	60	3200	510	3	180	9500	2300	6	30	1600	180	1.8				
8	150	6000	1700	8	120	4800	960	8	100	4000	800	8	60	2400	480	4	180	7200	2000	8	30	1200	190	2.4				
10	150	4800	1500	10	120	3800	840	10	100	3200	900	10	60	1900	420	5	180	5700	1800	10	30	950	210	3				
12	150	4000	1300	12	120	3200	770	12	100	2700	860	12	60	1600	380	6	180	4800	1500	12	30	800	200	3.6				
16	150	3000	1100	12	120	2400	670	12	100	2000	640	12	60	1200	340	8	180	3600	1300	12	30	600	150	4.8				
20	150	2400	860	12	120	1900	530	12	100	1600	510	12	60	950	270	10	180	2900	1000	12	30	480	120	6				
25	150	1900	760	12	120	1500	420	12	100	1300	420	12	60	760	210	12	180	2300	920	12	30	380	100	7.5				

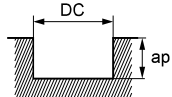

DC:Dia.

General purpose cutting conditions

Work material	P				M				S				M				S				N				S			
	Carbon steel, Alloy steel, Mild steel				Pre-hardened steel, Alloy steel, Alloy tool steel				Austenitic, Ferritic and Martensitic stainless steels, Titanium alloys				Hardened stainless steels, Cobalt chromium alloy				Copper, Copper alloy				Heat resistant alloys							
	Ck45, 41CrMo4, St44-2, Ck10				NAK, X36CrMo17, 40CrNiMoA, X210Cr12, SKT				X5CrNi189, X8CrNiMo173, Ti6Al4V				X5CrNiCuNb16-4, X7CrNiAl17-7				Inconel718											
Dia. DC (mm)	Cutting speed (m/min)	Revolution (mir ⁻¹)	Feed rate (mm/min)	Depth of cut ap (mm)	Cutting speed (m/min)	Revolution (mir ⁻¹)	Feed rate (mm/min)	Depth of cut ap (mm)	Cutting speed (m/min)	Revolution (mir ⁻¹)	Feed rate (mm/min)	Depth of cut ap (mm)	Cutting speed (m/min)	Revolution (mir ⁻¹)	Feed rate (mm/min)	Depth of cut ap (mm)	Cutting speed (m/min)	Revolution (mir ⁻¹)	Feed rate (mm/min)	Depth of cut ap (mm)	Cutting speed (m/min)	Revolution (mir ⁻¹)	Feed rate (mm/min)	Depth of cut ap (mm)				
1	100	32000	500	1	80	25000	250	1	80	25000	300	1	50	16000	150	0.5	120	38000	590	1	25	8000	67	0.3				
2	100	16000	550	2	80	13000	270	2	60	9500	250	2	50	8000	170	1	120	19000	650	2	25	4000	74	0.6				
3	100	11000	670	3	80	8500	310	3	60	6400	250	3	50	5300	200	1.5	120	13000	790	3	25	2700	86	0.9				
4	100	8000	840	4	80	6400	410	4	60	4800	280	4	50	4000	250	2	120	9500	1000	4	25	2000	93	1.2				
5	100	6400	840	5	80	5100	410	5	60	3800	280	5	50	3200	250	2.5	120	7600	1000	5	25	1600	95	1.5				
6	100	5300	840	6	80	4200	440	6	60	3200	300	6	50	2700	290	3	120	6400	1000	6	25	1300	96	1.8				
8	100	4000	740	8	80	3200	420	8	60	2400	320	8	50	2000	260	4	120	4800	890	8	25	990	100	2.4				
10	100	3200	680	10	80	2500	360	10	60	1900	350	10	50	1600	230	5	120	3800	800	10	25	800	120	3				
12	100	2700	570	12	80	2100	330	12	60	1600	340	12	50	1300	210	6	120	3200	680	12	25	660	110	3.6				
16	100	2000	480	12	80	1600	300	12	60	1200	250	12	50	990	180	8	120	2400	570	12	25	500	84	4.8				
20	100	1600	380	12	80	1300	240	12	60	950	200	12	50	800	150	10	120	1900	450	12	25	400	68	6				
25	100	1300	340	12	80	1000	180	12	60	760	160	12	50	640	120	12	120	1500	400	12	25	320	50	7.5				

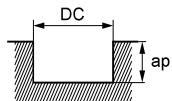

DC:Dia.

Note 1) VQ coating has less electrical conductivity; therefore an external contact type (electrically transmitted) tool setter may not work.

When measuring the tool length, please use an internal contact type (non-electrical type) tool setter or a laser type tool setter.

Note 2) Effective cutting of stainless steel, titanium alloys and heat-resistant alloys etc. can be achieved with the use of emulsion coolant.
Note 3) Chattering can still occur if the machine rigidity and clamping method are insufficient.

In these cases the feed and speed should be reduced proportionately.

Note 4) When the depth of cut is smaller than shown the revolution and feed rate can be increased.

VQ END MILLS

VQJHV

End mill, Semi-long cut length, Irregular helix, 4 flute



Carbon Steel, Alloy Steel, Cast Iron (<30HRC)	Tool Steel, Pre-Hardened Steel, Hardened Steel (<=45HRC)	Hardened Steel (<=55HRC)	Hardened Steel (>55HRC)	Austenitic Stainless Steel	Titanium Alloy, Heat Resistant Alloy	Copper Alloy	Aluminium Alloy
○	○			○	○	○	

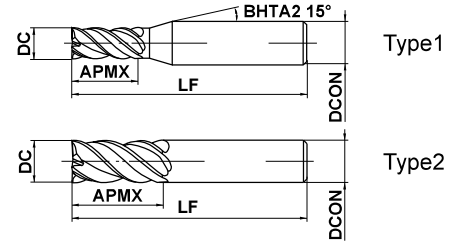

SOLID END MILLS

	DC ≤ 12	DC > 12			
	0 - 0.020	0 - 0.030			
	4 ≤ DCON ≤ 6	8 ≤ DCON ≤ 10	12 ≤ DCON ≤ 16	DCON = 20	
	0 - 0.008	0 - 0.009	0 - 0.011	0 - 0.013	

● VQ vibration control end mills for reduced chattering, enabling a stable performance on difficult-to-cut materials and long overhang applications.

(mm)

Order Number	DC	APMX	LF	DCON	Flutes	Stock	Type
VQJHVD0100	1	4	45	4	4	●	1
VQJHVD0150	1.5	6	45	4	4	●	1
VQJHVD0200	2	8	60	6	4	●	1
VQJHVD0250	2.5	10	60	6	4	●	1
VQJHVD0300	3	12	60	6	4	●	1
VQJHVD0350	3.5	14	60	6	4	●	1
VQJHVD0400	4	16	60	6	4	●	1
VQJHVD0450	4.5	18	60	6	4	●	1
VQJHVD0500	5	20	60	6	4	●	1
VQJHVD0600	6	24	60	6	4	●	2
VQJHVD0700	7	25	80	8	4	●	1
VQJHVD0800	8	28	80	8	4	●	2
VQJHVD0900	9	32	90	10	4	●	1
VQJHVD1000	10	35	90	10	4	●	2
VQJHVD1200	12	40	100	12	4	●	2
VQJHVD1600	16	55	125	16	4	●	2
VQJHVD2000	20	70	140	20	4	●	2

● : Inventory maintained.

SQUARE

BALL

RADIUS

TAPER

BARREL

ROUGHING

RECOMMENDED CUTTING CONDITIONS

Side milling

Work material	P					M					S									
	Carbon steel, Alloy steel, Mild steel Ck45, 41CrMo4, St44-2, Ck10					Pre-hardened steel, Carbon steel, Alloy steel, Alloy tool steel NAK, X36CrMo17, 40CrNiMoA, X210Cr12, SKT					Austenitic, Ferritic and Martensitic stainless steels, Titanium alloys X5CrNi189, X8CrNiMo173, Ti6Al4V					Hardened stainless steels, Cobalt chromium alloy X5CrNiCuNb16-4, X7CrNiAl17-7				
Dia. DC (mm)	Cutting speed (m/min)	Revolution (min ⁻¹)	Feed rate (mm/min)	Depth of cut ap (mm)	Depth of cut ae (mm)	Cutting speed (m/min)	Revolution (min ⁻¹)	Feed rate (mm/min)	Depth of cut ap (mm)	Depth of cut ae (mm)	Cutting speed (m/min)	Revolution (min ⁻¹)	Feed rate (mm/min)	Depth of cut ap (mm)	Depth of cut ae (mm)	Cutting speed (m/min)	Revolution (min ⁻¹)	Feed rate (mm/min)	Depth of cut ap (mm)	Depth of cut ae (mm)
1	130	40000	530	2.5	0.1	100	32000	410	2.5	0.1	80	25000	300	2.5	0.05	75	24000	290	2.5	0.05
2	130	21000	700	5	0.2	100	16000	510	5	0.2	80	13000	390	5	0.1	75	12000	360	5	0.1
3	130	14000	960	7.5	0.3	100	11000	680	7.5	0.3	80	8500	490	7.5	0.15	75	8000	460	7.5	0.15
4	130	10000	1000	10	0.4	100	8000	690	10	0.4	80	6400	540	10	0.2	75	6000	510	10	0.2
5	130	8300	1100	12.5	0.5	100	6400	730	12.5	0.5	80	5100	570	12.5	0.25	75	4800	540	12.5	0.25
6	130	6900	1200	15	0.6	100	5300	810	15	0.6	80	4200	630	15	0.3	75	4000	600	15	0.3
8	130	5200	1200	20	0.8	100	4000	840	20	0.8	80	3200	640	20	0.4	75	3000	600	20	0.4
10	130	4100	1100	25	1	100	3200	810	25	1	80	2500	590	25	0.5	75	2400	570	25	0.5
12	130	3400	1100	30	1.2	100	2700	780	30	1.2	80	2100	550	30	0.6	75	2000	520	30	0.6
16	130	2600	920	40	1.6	100	2000	640	40	1.6	80	1600	450	40	0.8	75	1500	420	40	0.8
20	130	2100	820	50	2	100	1600	570	50	2	80	1300	420	50	1	75	1200	390	50	1

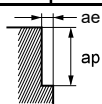

Work material	N					S				
	Copper, Copper alloy					Heat resistant alloys Inconel718				
Dia. DC (mm)	Cutting speed (m/min)	Revolution (min ⁻¹)	Feed rate (mm/min)	Depth of cut ap (mm)	Depth of cut ae (mm)	Cutting speed (m/min)	Revolution (min ⁻¹)	Feed rate (mm/min)	Depth of cut ap (mm)	Depth of cut ae (mm)
1	130	40000	530	2.5	0.1	40	13000	73	2.5	0.02
2	160	25000	830	5	0.2	40	6400	90	5	0.04
3	160	17000	1200	7.5	0.3	40	4200	130	7.5	0.06
4	160	13000	1300	10	0.4	40	3200	190	10	0.08
5	160	10000	1300	12.5	0.5	40	2500	180	12.5	0.1
6	160	8500	1500	15	0.6	40	2100	180	15	0.12
8	160	6400	1500	20	0.8	40	1600	170	20	0.16
10	160	5100	1300	25	1	40	1300	170	25	0.2
12	160	4200	1300	30	1.2	40	1100	140	30	0.24
16	160	3200	1100	40	1.6	40	800	110	40	0.32
20	160	2500	970	50	2	40	640	80	50	0.4

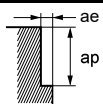

- Note 1) VQ coating has less electrical conductivity; therefore an external contact type (electrically transmitted) tool setter may not work. When measuring the tool length, please use an internal contact type (non-electrical type) tool setter or a laser type tool setter.
- Note 2) Effective cutting of stainless steel, titanium alloys and heat-resistant alloys etc. can be achieved with the use of emulsion coolant.
- Note 3) Chattering can still occur if the machine rigidity and clamping method are insufficient. In these cases the feed and speed should be reduced proportionately.
- Note 4) When the depth of cut is smaller than shown the revolution and feed rate can be increased.

SOLID END MILLS

SQUARE

BALL

RADIUS

TAPER

BARREL

ROUGHING

VQ END MILLS

VQXL

End mill, Short cut length, Long neck, 3/4 flutes



DC≤0.3

DC≥0.4

Carbon Steel, Alloy Steel, Cast Iron (<30HRC)	Tool Steel, Pre-Hardened Steel, Hardened Steel (≤45HRC)	Hardened Steel (≤55HRC)	Hardened Steel (>55HRC)	Austenitic Stainless Steel	Titanium Alloy, Heat Resistant Alloy	Copper Alloy	Aluminium Alloy
○	○			○	○	○	

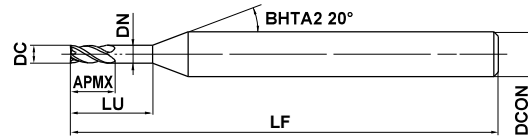

Type1

SOLID END MILLS



DC≤1				
0				
-0.010				
DCON=4				
0				
-0.005				



- Enhancing efficiency with improved chip disposal by adopting the VQ coating. Increased number of flutes provides higher efficiency and longer tool life.

(mm)

Order Number	DC	APMX	LU	DN	LF	DCON	Flutes	Stock	Type
VQXLD0020N006	0.2	0.3	0.6	0.18	40	4	3	●	1
VQXLD0030N009	0.3	0.5	0.9	0.28	40	4	3	●	1
VQXLD0030N015	0.3	0.5	1.5	0.28	40	4	3	●	1
VQXLD0040N010	0.4	0.6	1	0.37	40	4	4	●	1
VQXLD0040N018	0.4	0.6	1.8	0.37	40	4	4	●	1
VQXLD0050N015	0.5	0.7	1.5	0.47	40	4	4	●	1
VQXLD0050N025	0.5	0.7	2.5	0.47	40	4	4	●	1
VQXLD0050N030	0.5	0.7	3	0.47	40	4	4	●	1
VQXLD0060N030	0.6	0.9	3	0.57	40	4	4	●	1
VQXLD0070N035	0.7	1	3.5	0.67	40	4	4	●	1
VQXLD0080N024	0.8	1.2	2.4	0.77	40	4	4	●	1
VQXLD0080N030	0.8	1.2	3	0.77	40	4	4	●	1
VQXLD0080N040	0.8	1.2	4	0.77	40	4	4	●	1
VQXLD0100N050	1	1.5	5	0.96	40	4	4	●	1

SQUARE

BALL

RADIUS

TAPER

BARREL

ROUGHING

Torque chart

Order Number	ISO 10664
	Torque type
VQXLD0020N006	T4
VQXLD0030N009	T6
VQXLD0030N015	T6
VQXLD0040N010	T8
VQXLD0040N018	T8
VQXLD0050N015	T15
VQXLD0050N025	T15
VQXLD0050N030	T15
VQXLD0080N024	TS25
VQXLD0080N040	TS25
VQXLD0100N050	T40

● : Inventory maintained.

RECOMMENDED CUTTING CONDITIONS

Side milling

		P	M	S	N			P	H	S		
Work material		Carbon steel, Alloy steel, Mild steel, Alloy tool steel, Austenitic stainless steels, Titanium alloys Cobalt chromium alloy, Copper, Copper alloy					Heat resistant alloys, Pre-hardened steel, Hardened steel					
		Ck45, 41CrMo4, 36CrNiMo4, X5CrNi189, X5CrNiMo1810, X2CrNiN1810, X2CrNiMoN1813					Inconel 718, NAK, X36CrMo17, X40CrMoV51, 55NiCrMoV6, X46Cr13					
Dia. DC (mm)	Neck Length LU (mm)	Cutting speed (m/min)	Revolution (min ⁻¹)	Feed rate (mm/min)	Depth of cut ap (mm)	Depth of cut ae (mm)	Cutting speed (m/min)	Revolution (min ⁻¹)	Feed rate (mm/min)	Depth of cut ap (mm)	Depth of cut ae (mm)	
0.2	0.6	25	40000	360	0.03	0.01	20	32000	290	0.03	0.01	
0.3	0.9	40	40000	480	0.045	0.015	20	21000	250	0.045	0.015	
0.3	1.5	40	40000	360	0.045	0.015	20	21000	190	0.045	0.015	
0.4	1.2	50	40000	800	0.06	0.02	20	16000	320	0.06	0.02	
0.4	2	50	40000	560	0.06	0.02	20	16000	220	0.06	0.025	
0.5	1.5	60	38000	910	0.075	0.025	20	13000	310	0.075	0.025	
0.5	2.5	60	38000	610	0.075	0.025	20	13000	210	0.075	0.025	
0.5	3	60	38000	550	0.075	0.025	20	13000	180	0.075	0.025	
0.6	3	60	32000	640	0.09	0.03	20	10500	210	0.09	0.03	
0.7	3.5	60	27000	650	0.11	0.035	20	9100	200	0.11	0.035	
0.8	2.4	60	24000	960	0.12	0.04	20	8000	260	0.12	0.04	
0.8	3	60	24000	860	0.12	0.04	20	8000	230	0.12	0.04	
0.8	4	60	24000	670	0.12	0.04	20	8000	190	0.12	0.04	
1	5	60	20000	800	0.15	0.05	20	6500	210	0.15	0.05	
Depth of cut												

Bottom face milling

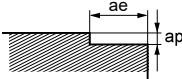
		P	M	S	N			P	H	S		
Work material		Carbon steel, Alloy steel, Mild steel, Alloy tool steel, Austenitic stainless steels, Titanium alloys Cobalt chromium alloy, Copper, Copper alloy					Heat resistant alloys, Pre-hardened steel, Hardened steel					
		Ck45, 41CrMo4, 36CrNiMo4, X5CrNi189, X5CrNiMo1810, X2CrNiN1810, X2CrNiMoN1813					Inconel 718, NAK, X36CrMo17, X40CrMoV51, 55NiCrMoV6, X46Cr13					
Dia. DC (mm)	Neck Length LU (mm)	Cutting speed (m/min)	Revolution (min ⁻¹)	Feed rate (mm/min)	Depth of cut ap (mm)	Depth of cut ae (mm)	Cutting speed (m/min)	Revolution (min ⁻¹)	Feed rate (mm/min)	Depth of cut ap (mm)	Depth of cut ae (mm)	
0.2	0.6	25	40000	360	0.015	≤0.2	20	32000	290	0.015	≤0.1	
0.3	0.9	40	40000	480	0.025	≤0.3	20	21000	250	0.025	≤0.15	
0.3	1.5	40	40000	360	0.02	≤0.3	20	21000	190	0.02	≤0.15	
0.4	1.2	50	40000	800	0.03	≤0.4	20	16000	320	0.03	≤0.2	
0.4	2	50	40000	560	0.02	≤0.4	20	16000	220	0.02	≤0.2	
0.5	1.5	60	38000	910	0.04	≤0.5	20	13000	310	0.04	≤0.25	
0.5	2.5	60	38000	610	0.03	≤0.5	20	13000	210	0.03	≤0.25	
0.5	3	60	38000	550	0.03	≤0.5	20	13000	180	0.03	≤0.25	
0.6	3	60	32000	640	0.035	≤0.6	20	10500	210	0.035	≤0.3	
0.7	3.5	60	27000	640	0.035	≤0.7	20	9100	190	0.035	≤0.35	
0.8	2.4	60	24000	960	0.06	≤0.8	20	8000	260	0.06	≤0.4	
0.8	3	60	24000	840	0.05	≤0.8	20	8000	230	0.05	≤0.4	
0.8	4	60	24000	670	0.04	≤0.8	20	8000	190	0.04	≤0.4	
1	5	60	20000	800	0.05	≤1	20	6500	210	0.05	≤0.5	
Depth of cut												

Note 1) VQ coating has less electrical conductivity; therefore an external contact type (electrically transmitted) tool setter may not work.

When measuring the tool length, please use an internal contact type (non-electrical type) tool setter or a laser type tool setter.

Note 2) Effective cutting of stainless steel, titanium alloys and heat-resistant alloys etc. can be achieved with the use of emulsion coolant.

Note 3) Chattering can still occur if the machine rigidity and clamping method are insufficient.

In these cases the feed and speed should be reduced proportionately.

VQ END MILLS

VQXL

End mill, Short cut length, Long neck, 3/4 flutes

CARBIDE

SOLID END MILLS

SQUARE

BALL

RADIUS

TAPER

BARREL

ROUGHING

Slotting

		P	M	S	N	P	H	S	
Work material		Carbon steel, Alloy steel, Mild steel, Alloy tool steel, Austenitic stainless steels, Titanium alloys, Cobalt chromium alloy, Copper, Copper alloy				Heat resistant alloys, Pre-hardened steel, Hardened steel			
		Ck45, 41CrMo4, 36CrNiMo4, X5CrNi189, X5CrNiMo1810, X2CrNiN1810, X2CrNiMoN1813				Inconel 718, NAK, X36CrMo17, X40CrMoV51, 55NiCrMoV6, X46Cr13			
Dia. DC (mm)	Neck Length LU (mm)	Cutting speed (m/min)	Revolution (min ⁻¹)	Feed rate (mm/min)	Depth of cut ap (mm)	Cutting speed (m/min)	Revolution (min ⁻¹)	Feed rate (mm/min)	Depth of cut ap (mm)
0.2	0.6	20	30000	270	0.03	15	24000	220	0.03
0.3	0.9	30	30000	360	0.045	14	15000	180	0.045
0.3	1.5	30	30000	270	0.045	14	15000	140	0.045
0.4	1.2	40	30000	600	0.06	15	12000	240	0.06
0.4	2	40	30000	420	0.06	15	12000	170	0.06
0.5	1.5	45	28000	670	0.075	15	9500	230	0.075
0.5	2.5	45	28000	450	0.075	15	9500	150	0.075
0.5	3	45	28000	390	0.075	15	9500	130	0.075
0.6	3	45	24000	480	0.09	15	7800	160	0.09
0.7	3.5	45	20000	480	0.11	15	6800	140	0.11
0.8	2.4	45	18000	720	0.12	15	6000	190	0.12
0.8	3	45	18000	650	0.12	15	6000	170	0.12
0.8	4	45	18000	500	0.12	15	6000	140	0.12
1	5	45	15000	600	0.15	15	4800	150	0.15

Depth of cut

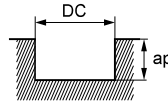

DC: Dia.

Note 1) VQ coating has less electrical conductivity; therefore an external contact type (electrically transmitted) tool setter may not work.

When measuring the tool length, please use an internal contact type (non-electrical type) tool setter or a laser type tool setter.

Note 2) Effective cutting of stainless steel, titanium alloys and heat-resistant alloys etc. can be achieved with the use of emulsion coolant.

Note 3) Chattering can still occur if the machine rigidity and clamping method are insufficient.

In these cases the feed and speed should be reduced proportionately.

VQ6MHVCH

End mill, Medium cut length, irregular helix, 6 flute.
With multiple internal through coolant holes



CARBIDE

Carbon Steel, Alloy Steel, Cast Iron (<30HRC)	Tool Steel, Pre-Hardened Steel, Hardened Steel (≤45HRC)	Hardened Steel (≤55HRC)	Hardened Steel (>55HRC)	Austenitic Stainless Steel	Titanium Alloy, Heat Resistant Alloy	Copper Alloy	Aluminium Alloy
○	○			◎	◎	○	

CoolStar
END MILLS

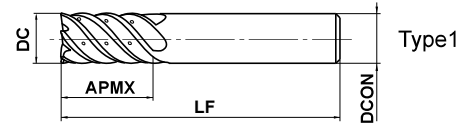

DC ≤ 12	DC > 12			
0 - 0.020	0 - 0.030			
DCON = 10	DCON = 12	DCON = 16	DCON = 20	
0 - 0.009	0 - 0.011	0 - 0.011	0 - 0.013	

● Vibration control end mill with multiple internal through coolant holes ensures stable machining on difficult-to-cut materials and applications requiring long overhangs.

(mm)

Order Number	DC	APMX	LF	DCON	Flutes	Stock	Type
VQ6MHVCHD1000	10	22	70	10	6	●	1
VQ6MHVCHD1200	12	26	75	12	6	●	1
VQ6MHVCHD1600	16	32	90	16	6	●	1
VQ6MHVCHD2000	20	38	100	20	6	●	1

SOLID END MILLS

SOLID END MILLS

SQUARE

BALL

RADIUS

TAPER

BARREL

ROUGHING

● : Inventory maintained.

VQ6MHVCH

End mill, Medium cut length, Irregular helix, 6 flute. With multiple internal through coolant holes.

CARBIDE

RECOMMENDED CUTTING CONDITIONS

Side milling

Work material	P		M	S	N		S	
	Revolution (min ⁻¹)	Feed rate (mm/min)	Revolution (min ⁻¹)	Feed rate (mm/min)	Revolution (min ⁻¹)	Feed rate (mm/min)	Revolution (min ⁻¹)	Feed rate (mm/min)
Alloy steel, Tool steel, Pre-hardened steel X40CrMoV51			Austenitic Stainless Steel (≤200HB), Titanium Alloy X5CrNi189, X5CrNiMo1810, Ti-6Al-4V		Copper, Copper alloy		Heat Resistant Alloys Inconel 718	
Dia. DC (mm)								
10	—	—	4800	2000	—	—	1300	260
12	—	—	4000	2000	—	—	1100	230
16	4000	2200	3000	1600	2400	1400	800	180
20	3200	1900	2400	1400	1900	1100	640	150
Depth of Cut								

DC: Dia.

Trochoidal slotting

Work material	P		M	S
	Revolution (min ⁻¹)	Feed rate (mm/min)	Revolution (min ⁻¹)	Feed rate (mm/min)
Alloy steel, Tool steel, Pre-hardened steel X40CrMoV51			Austenitic stainless steel (≤200HB), Titanium alloy X5CrNi189, X5CrNiMo1810, Ti-6Al-4V	
Dia. DC (mm)				
10	—	—	4800	1400
12	—	—	4000	1200
16	4000	1600	3000	1100
20	3200	1400	2400	900
Depth of cut				

DC: Dia.

Note 1) If the depth of cut is shallow, the revolution and feed rate can be increased.

Note 2) The irregular helix flute end mill has a larger effect on controlling vibration when compared to standard end mills.

However, if the rigidity of the machine or the workpiece installation is very low, then vibration can occur.

In this case, please reduce the revolution and feed rate proportionately.

SOLID END MILLS

SQUARE

BALL

RADIUS

TAPER

BARREL

ROUGHING

VQMHV RB

Corner radius end mill, Medium cut length, Irregular helix, 4 flute.



CARBIDE

Carbon Steel, Alloy Steel, Cast Iron (<30HRC)	Tool Steel, Pre-Hardened Steel, Hardened Steel (<=45HRC)	Hardened Steel (<=55HRC)	Hardened Steel (>55HRC)	Austenitic Stainless Steel	Titanium Alloy, Heat Resistant Alloy	Copper Alloy	Aluminium Alloy
○	○			○	○	○	

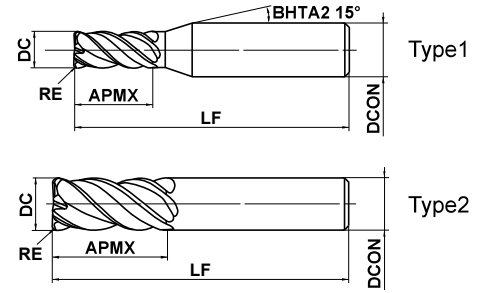

	0.2 ≤ RE ≤ 6.35			
	±0.015			
	DC ≤ 12	DC > 12		
	⁰ / _{-0.020}	⁰ / _{-0.030}		
	4 ≤ DCON ≤ 6	8 ≤ DCON ≤ 10	12 ≤ DCON ≤ 16	DCON = 20
	⁰ / _{-0.008}	⁰ / _{-0.009}	⁰ / _{-0.011}	⁰ / _{-0.013}

● VQ vibration control end mills for reduced chattering, enable a stable performance on difficult-to-cut materials and long overhang applications.

(mm)

Order Number	DC	RE	APMX	LF	DCON	Flutes	Stock	Type
VQMHV RBD0200R020	2	0.2	4	45	4	4	●	1
VQMHV RBD0200R030	2	0.3	4	45	4	4	●	1
VQMHV RBD0300R020	3	0.2	8	45	6	4	●	1
VQMHV RBD0300R030	3	0.3	8	45	6	4	●	1
VQMHV RBD0300R050	3	0.5	8	45	6	4	●	1
VQMHV RBD0400R020	4	0.2	11	45	6	4	●	1
VQMHV RBD0400R030	4	0.3	11	45	6	4	●	1
VQMHV RBD0400R050	4	0.5	11	45	6	4	●	1
VQMHV RBD0500R020	5	0.2	13	50	6	4	●	1
VQMHV RBD0500R030	5	0.3	13	50	6	4	●	1
VQMHV RBD0500R050	5	0.5	13	50	6	4	●	1
VQMHV RBD0500R100	5	1	13	50	6	4	●	1
VQMHV RBD0600R030	6	0.3	13	50	6	4	●	2
VQMHV RBD0600R050	6	0.5	13	50	6	4	●	2
VQMHV RBD0600R100	6	1	13	50	6	4	●	2
VQMHV RBD0800R030	8	0.3	19	60	8	4	●	2
VQMHV RBD0800R050	8	0.5	19	60	8	4	●	2
VQMHV RBD0800R100	8	1	19	60	8	4	●	2
VQMHV RBD0800R150	8	1.5	19	60	8	4	●	2
VQMHV RBD1000R030	10	0.3	22	70	10	4	●	2
VQMHV RBD1000R050	10	0.5	22	70	10	4	●	2
VQMHV RBD1000R100	10	1	22	70	10	4	●	2
VQMHV RBD1000R150	10	1.5	22	70	10	4	●	2
VQMHV RBD1000R200	10	2	22	70	10	4	●	2
VQMHV RBD1200R050	12	0.5	26	75	12	4	●	2
VQMHV RBD1200R100	12	1	26	75	12	4	●	2
VQMHV RBD1200R150	12	1.5	26	75	12	4	●	2
VQMHV RBD1200R200	12	2	26	75	12	4	●	2
VQMHV RBD1200R250	12	2.5	26	75	12	4	●	2
VQMHV RBD1200R300	12	3	26	75	12	4	●	2
VQMHV RBD1600R100	16	1	35	90	16	4	●	2
VQMHV RBD1600R150	16	1.5	35	90	16	4	●	2
VQMHV RBD1600R200	16	2	35	90	16	4	●	2
VQMHV RBD1600R250	16	2.5	35	90	16	4	●	2

● : Inventory maintained.

SOLID END MILLS

SQUARE

BALL

RADIUS

TAPER

BARREL

ROUGHING

VQ END MILLS

VQMHRB

Corner radius end mill, Medium cut length, Irregular helix, 4 flute

(mm)

Order Number	DC	RE	APMX	LF	DCON	Flutes	Stock	Type
VQMHRBD1600R300	16	3	35	90	16	4	●	2
VQMHRBD1600R400	16	4	35	90	16	4	●	2
VQMHRBD1600R500	16	5	35	90	16	4	●	2
VQMHRBD2000R100	20	1	45	110	20	4	●	2
VQMHRBD2000R150	20	1.5	45	110	20	4	●	2
VQMHRBD2000R200	20	2	45	110	20	4	●	2
VQMHRBD2000R250	20	2.5	45	110	20	4	●	2
VQMHRBD2000R300	20	3	45	110	20	4	●	2
VQMHRBD2000R400	20	4	45	110	20	4	●	2
VQMHRBD2000R500	20	5	45	110	20	4	●	2
VQMHRBD2000R635	20	6.35	45	110	20	4	●	2

CARBIDE

—

SOLID END MILLS

SQUARE

BALL

RADIUS

TAPER

BARREL

ROUGHING

● : Inventory maintained.

RECOMMENDED CUTTING CONDITIONS

■ Side milling

When machine and work material rigidity and chip discharge properties are sufficient, please select the high efficiency cutting conditions.
When machine rigidity, work material rigidity or chip discharge properties are insufficient, please select general-purpose cutting conditions.

High efficiency cutting conditions

Work material	P										M					S				
	Carbon steel, Alloy steel, Mild steel					Pre-hardened steel, Alloy steel, Alloy tool steel					Austenitic, Ferritic and Martensitic stainless steels, Titanium alloys					Hardened stainless steels, Cobalt chromium alloy				
	Ck45, 41CrMo4, St44-2, Ck10					NAK, X36CrMo17, 40CrNiMoA, X210Cr12, SKT					X5CrNi189, X8CrNiMo173, Ti6Al4V					X5CrNiCuNb16-4, X7CrNiAl17-7				
Dia. DC (mm)	Cutting speed (m/min)	Revolution (min ⁻¹)	Feed rate (mm/min)	Depth of cut ap (mm)	Depth of cut ae (mm)	Cutting speed (m/min)	Revolution (min ⁻¹)	Feed rate (mm/min)	Depth of cut ap (mm)	Depth of cut ae (mm)	Cutting speed (m/min)	Revolution (min ⁻¹)	Feed rate (mm/min)	Depth of cut ap (mm)	Depth of cut ae (mm)	Cutting speed (m/min)	Revolution (min ⁻¹)	Feed rate (mm/min)	Depth of cut ap (mm)	Depth of cut ae (mm)
2	150	24000	2400	3	0.6	120	19000	1100	3	0.6	100	16000	830	3	0.6	75	12000	720	3	0.4
3	150	16000	2600	4.5	0.9	120	13000	1200	4.5	0.9	100	11000	880	4.5	0.9	75	8000	770	4.5	0.6
4	150	12000	2600	6	1.2	120	9500	1300	6	1.2	100	8000	900	6	1.2	75	6000	790	6	0.8
5	150	9500	2600	7.5	1.5	120	7600	1300	7.5	1.5	100	6400	900	7.5	1.5	75	4800	810	7.5	1
6	150	8000	2600	9	1.8	120	6400	1300	9	1.8	100	5300	1100	9	1.8	75	4000	810	9	1.2
8	150	6000	2500	12	2.4	120	4800	1300	12	2.4	100	4000	1200	12	2.4	75	3000	840	12	1.6
10	150	4800	2300	15	3	120	3800	1200	15	3	100	3200	1300	15	3	75	2400	770	15	2
12	150	4000	1900	18	3.6	120	3200	1200	18	3.6	100	2700	1200	18	3.6	75	2000	720	18	2.4
16	150	3000	1600	24	4.8	120	2400	960	24	4.8	100	2000	960	24	4.8	75	1500	600	24	3.2
20	150	2400	1300	30	6	120	1900	760	30	6	100	1600	770	30	6	75	1200	480	30	4



SOLID END MILLS

SQUARE

General purpose cutting conditions

Work material	P										M					S				
	Carbon steel, Alloy steel, Mild steel					Pre-hardened steel, Alloy steel, Alloy tool steel					Austenitic, Ferritic and Martensitic stainless steels, Titanium alloys					Hardened stainless steels, Cobalt chromium alloy				
	Ck45, 41CrMo4, St44-2, Ck10					NAK, X36CrMo17, 40CrNiMoA, X210Cr12, SKT					X5CrNi189, X8CrNiMo173, Ti6Al4V					X5CrNiCuNb16-4, X7CrNiAl17-7				
Dia. DC (mm)	Cutting speed (m/min)	Revolution (min ⁻¹)	Feed rate (mm/min)	Depth of cut ap (mm)	Depth of cut ae (mm)	Cutting speed (m/min)	Revolution (min ⁻¹)	Feed rate (mm/min)	Depth of cut ap (mm)	Depth of cut ae (mm)	Cutting speed (m/min)	Revolution (min ⁻¹)	Feed rate (mm/min)	Depth of cut ap (mm)	Depth of cut ae (mm)	Cutting speed (m/min)	Revolution (min ⁻¹)	Feed rate (mm/min)	Depth of cut ap (mm)	Depth of cut ae (mm)
2	120	19000	1300	3	0.6	100	16000	630	3	0.6	80	13000	450	1.5	0.2	70	11000	440	3	0.4
3	120	13000	1400	4.5	0.9	100	11000	700	4.5	0.9	80	8500	450	2.2	0.3	70	7400	470	4.5	0.6
4	120	9500	1400	6	1.2	100	8000	700	6	1.2	80	6400	470	3	0.6	70	5600	490	6	0.8
5	120	7600	1400	7.5	1.5	100	6400	710	7.5	1.5	80	5100	470	4.5	0.9	70	4500	500	7.5	1
6	120	6400	1400	9	1.8	100	5300	710	9	1.8	80	4200	580	6	1.2	70	3700	500	9	1.2
8	120	4800	1300	12	2.4	100	4000	740	12	2.4	80	3200	630	7.5	1.5	70	2800	520	12	1.6
10	120	3800	1200	15	3	100	3200	680	15	3	80	2500	660	9	1.8	70	2200	460	15	2
12	120	3200	1000	18	3.6	100	2700	640	18	3.6	80	2100	610	12	2.4	70	1900	450	18	2.4
16	120	2400	860	24	4.8	100	2000	530	24	4.8	80	1600	510	15	3	70	1400	370	24	3.2
20	120	1900	680	30	6	100	1600	420	30	6	80	1300	410	18	3.6	70	1100	290	30	4



BALL

RADIUS

TAPER

BARREL

ROUGHING

- Note 1) VQ coating has less electrical conductivity; therefore an external contact type (electrically transmitted) tool setter may not work.
When measuring the tool length, please use an internal contact type (non-electrical type) tool setter or a laser type tool setter.
- Note 2) Effective cutting of stainless steel, titanium alloys and heat-resistant alloys etc. can be achieved with the use of emulsion coolant.
- Note 3) Chattering can still occur if the machine rigidity and clamping method are insufficient.
In these cases the feed and speed should be reduced proportionately.
- Note 4) When the depth of cut is smaller than shown the revolution and feed rate can be increased.

VQ END MILLS

VQM HVRB

Corner radius end mill, Medium cut length, Irregular helix, 4 flute

CARBIDE

SOLID END MILLS

SQUARE

BALL

RADIUS

TAPER

BARREL

ROUGHING

Side milling

When machine and work material rigidity and chip discharge properties are sufficient, please select the high efficiency cutting conditions.
When machine rigidity, work material rigidity or chip discharge properties are insufficient, please select general-purpose cutting conditions.

High efficiency cutting conditions

Work material	N					S				
	Copper, Copper alloy					Heat resistant alloys Inconel718				
Dia. DC (mm)	Cutting speed (m/min)	Revolution (min ⁻¹)	Feed rate (mm/min)	Depth of cut ap (mm)	Depth of cut ae (mm)	Cutting speed (m/min)	Revolution (min ⁻¹)	Feed rate (mm/min)	Depth of cut ap (mm)	Depth of cut ae (mm)
2	180	29000	2900	3	0.6	40	6400	230	3	0.2
3	180	19000	3000	4.5	0.9	40	4200	240	4.5	0.3
4	180	14000	3000	6	1.2	40	3200	240	6	0.4
5	180	11000	3000	7.5	1.5	40	2500	240	7.5	0.5
6	180	9500	3000	9	1.8	40	2100	250	9	0.6
8	180	7200	3000	12	2.4	40	1600	260	12	0.8
10	180	5700	2700	15	3	40	1300	290	15	1
12	180	4800	2300	18	3.6	40	1100	280	18	1.2
16	180	3600	1900	24	4.8	40	800	200	24	1.6
20	180	2900	1600	30	6	40	640	160	30	2

Depth of cut

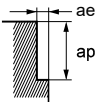

General purpose cutting conditions

Work material	N					S				
	Copper, Copper alloy					Heat resistant alloys Inconel718				
Dia. DC (mm)	Cutting speed (m/min)	Revolution (min ⁻¹)	Feed rate (mm/min)	Depth of cut ap (mm)	Depth of cut ae (mm)	Cutting speed (m/min)	Revolution (min ⁻¹)	Feed rate (mm/min)	Depth of cut ap (mm)	Depth of cut ae (mm)
2	140	22000	1500	3	0.6	30	4800	110	3	0.2
3	140	15000	1600	4.5	0.9	30	3200	120	4.5	0.3
4	140	11000	1600	6	1.2	30	2400	120	6	0.4
5	140	8900	1600	7.5	1.5	30	1900	120	7.5	0.5
6	140	7400	1600	9	1.8	30	1600	130	9	0.6
8	140	5600	1600	12	2.4	30	1200	130	12	0.8
10	140	4500	1400	15	3	30	950	140	15	1
12	140	3700	1200	18	3.6	30	800	140	18	1.2
16	140	2800	1000	24	4.8	30	600	100	24	1.6
20	140	2200	780	30	6	30	480	81	30	2

Depth of cut

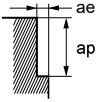

- Note 1) VQ coating has less electrical conductivity; therefore an external contact type (electrically transmitted) tool setter may not work.
When measuring the tool length, please use an internal contact type (non-electrical type) tool setter or a laser type tool setter.
- Note 2) Effective cutting of stainless steel, titanium alloys and heat-resistant alloys etc. can be achieved with the use of emulsion coolant.
- Note 3) Chattering can still occur if the machine rigidity and clamping method are insufficient.
In these cases the feed and speed should be reduced proportionately.
- Note 4) When the depth of cut is smaller than shown the revolution and feed rate can be increased.

Slotting

When machine and work material rigidity and chip discharge properties are sufficient, please select the high efficiency cutting conditions.
When machine rigidity, work material rigidity or chip discharge properties are insufficient, please select general-purpose cutting conditions.

High efficiency cutting conditions

Work material	P				M				S				M				S				N				S			
	Carbon steel, Alloy steel, Mild steel				Pre-hardened steel, Alloy steel, Alloy tool steel				Austenitic, Ferritic and Martensitic stainless steels, Titanium alloys				Hardened stainless steels, Cobalt chromium alloy				Copper, Copper alloy				Heat resistant alloys							
	Ck45, 41CrMo4, St44-2, Ck10				NAK, X36CrMo17, 40CrNiMoA, X210Cr12, SKT				X5CrNi189, X8CrNiMo173, Ti6Al4V				X5CrNiCuNb16-4, X7CrNiAl17-7								Inconel718							
Dia. DC (mm)	Cutting speed (m/min)	Revolution (mir ⁻¹)	Feed rate (mm/min)	Depth of cut ap (mm)	Cutting speed (m/min)	Revolution (mir ⁻¹)	Feed rate (mm/min)	Depth of cut ap (mm)	Cutting speed (m/min)	Revolution (mir ⁻¹)	Feed rate (mm/min)	Depth of cut ap (mm)	Cutting speed (m/min)	Revolution (mir ⁻¹)	Feed rate (mm/min)	Depth of cut ap (mm)	Cutting speed (m/min)	Revolution (mir ⁻¹)	Feed rate (mm/min)	Depth of cut ap (mm)	Cutting speed (m/min)	Revolution (mir ⁻¹)	Feed rate (mm/min)	Depth of cut ap (mm)	Cutting speed (m/min)	Revolution (mir ⁻¹)	Feed rate (mm/min)	Depth of cut ap (mm)
2	150	24000	1200	2	120	19000	610	2	100	16000	640	2	60	9500	300	1	180	29000	1500	2	30	4800	130	0.6				
3	150	16000	1500	3	120	13000	730	3	100	11000	660	3	60	6400	360	1.5	180	19000	1700	3	30	3200	150	0.9				
4	150	12000	1900	4	120	9500	910	4	100	8000	700	4	60	4800	460	2	180	14000	2200	4	30	2400	170	1.2				
5	150	9500	1900	5	120	7600	910	5	100	6400	720	5	60	3800	460	2.5	180	11000	2200	5	30	1900	170	1.5				
6	150	8000	1900	6	120	6400	1000	6	100	5300	740	6	60	3200	510	3	180	9500	2300	6	30	1600	180	1.8				
8	150	6000	1700	8	120	4800	960	8	100	4000	800	8	60	2400	480	4	180	7200	2000	8	30	1200	190	2.4				
10	150	4800	1500	10	120	3800	840	10	100	3200	900	10	60	1900	420	5	180	5700	1800	10	30	950	210	3				
12	150	4000	1300	12	120	3200	770	12	100	2700	860	12	60	1600	380	6	180	4800	1500	12	30	800	200	3.6				
16	150	3000	1100	12	120	2400	670	12	100	2000	640	12	60	1200	340	8	180	3600	1300	12	30	600	150	4.8				
20	150	2400	860	12	120	1900	530	12	100	1600	510	12	60	950	270	10	180	2900	1000	12	30	480	120	6				

DC: Dia.

General purpose cutting conditions

Work material	P				M				S				M				S				N				S			
	Carbon steel, Alloy steel, Mild steel				Pre-hardened steel, Alloy steel, Alloy tool steel				Austenitic, Ferritic and Martensitic stainless steels, Titanium alloys				Hardened stainless steels, Cobalt chromium alloy				Copper, Copper alloy				Heat resistant alloys							
	Ck45, 41CrMo4, St44-2, Ck10				NAK, X36CrMo17, 40CrNiMoA, X210Cr12, SKT				X5CrNi189, X8CrNiMo173, Ti6Al4V				X5CrNiCuNb16-4, X7CrNiAl17-7								Inconel718							
Dia. DC (mm)	Cutting speed (m/min)	Revolution (mir ⁻¹)	Feed rate (mm/min)	Depth of cut ap (mm)	Cutting speed (m/min)	Revolution (mir ⁻¹)	Feed rate (mm/min)	Depth of cut ap (mm)	Cutting speed (m/min)	Revolution (mir ⁻¹)	Feed rate (mm/min)	Depth of cut ap (mm)	Cutting speed (m/min)	Revolution (mir ⁻¹)	Feed rate (mm/min)	Depth of cut ap (mm)	Cutting speed (m/min)	Revolution (mir ⁻¹)	Feed rate (mm/min)	Depth of cut ap (mm)	Cutting speed (m/min)	Revolution (mir ⁻¹)	Feed rate (mm/min)	Depth of cut ap (mm)	Cutting speed (m/min)	Revolution (mir ⁻¹)	Feed rate (mm/min)	Depth of cut ap (mm)
2	100	16000	550	2	80	13000	270	2	60	9500	250	2	50	8000	170	1	120	19000	650	2	25	4000	74	0.6				
3	100	11000	670	3	80	8500	310	3	60	6400	250	3	50	5300	200	1.5	120	13000	790	3	25	2700	86	0.9				
4	100	8000	840	4	80	6400	410	4	60	4800	280	4	50	4000	250	2	120	9500	1000	4	25	2000	93	1.2				
5	100	6400	840	5	80	5100	410	5	60	3800	280	5	50	3200	250	2.5	120	7600	1000	5	25	1600	95	1.5				
6	100	5300	840	6	80	4200	440	6	60	3200	300	6	50	2700	290	3	120	6400	1000	6	25	1300	96	1.8				
8	100	4000	740	8	80	3200	420	8	60	2400	320	8	50	2000	260	4	120	4800	890	8	25	990	100	2.4				
10	100	3200	680	10	80	2500	360	10	60	1900	350	10	50	1600	230	5	120	3800	800	10	25	800	120	3				
12	100	2700	570	12	80	2100	330	12	60	1600	340	12	50	1300	210	6	120	3200	680	12	25	660	110	3.6				
16	100	2000	480	12	80	1600	300	12	60	1200	250	12	50	990	180	8	120	2400	570	12	25	500	84	4.8				
20	100	1600	380	12	80	1300	240	12	60	950	200	12	50	800	150	10	120	1900	450	12	25	400	68	6				

DC: Dia.

- Note 1) VQ coating has less electrical conductivity; therefore an external contact type (electrically transmitted) tool setter may not work. When measuring the tool length, please use an internal contact type (non-electrical type) tool setter or a laser type tool setter.
- Note 2) Effective cutting of stainless steel, titanium alloys and heat-resistant alloys etc. can be achieved with the use of emulsion coolant.
- Note 3) Chattering can still occur if the machine rigidity and clamping method are insufficient. In these cases the feed and speed should be reduced proportionately.
- Note 4) When the depth of cut is smaller than shown the revolution and feed rate can be increased.

SOLID END MILLS

SQUARE

BALL

RADIUS

TAPER

BARREL

ROUGHING

VQ END MILLS

VQMHRBF

Corner radius end mill, Medium cut length, Irregular helix, For finishing, 4 flute



Carbon Steel, Alloy Steel, Cast Iron (<30HRC)	Tool Steel, Pre-Hardened Steel, Hardened Steel (≤45HRC)	Hardened Steel (≤55HRC)	Hardened Steel (>55HRC)	Austenitic Stainless Steel	Titanium Alloy, Heat Resistant Alloy	Copper Alloy	Aluminium Alloy
○	○			○	○	○	

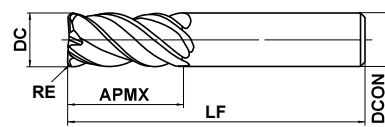

Type1

SOLID END MILLS

	$0.3 \leq RE \leq 3$				
	± 0.015				
	$DC \leq 12$	$DC > 12$			
	-0.020	-0.030			
	$DCON = 6$	$8 \leq DCON \leq 10$	$12 \leq DCON \leq 16$		
	-0.008	-0.009	-0.011		

- 4 flute irregular helix end mill for reduced vibration when machining difficult-to-cut materials.
- Ideal for finishing.

(mm)

Order Number	DC	RE	APMX	LF	DCON	Flutes	Stock	Type
VQMHRBFD0600R030	6	0.3	13	50	6	4	●	1
VQMHRBFD0600R050	6	0.5	13	50	6	4	●	1
VQMHRBFD0600R100	6	1	13	50	6	4	●	1
VQMHRBFD0800R050	8	0.5	19	60	8	4	●	1
VQMHRBFD0800R100	8	1	19	60	8	4	●	1
VQMHRBFD1000R030	10	0.3	22	70	10	4	●	1
VQMHRBFD1000R050	10	0.5	22	70	10	4	●	1
VQMHRBFD1000R100	10	1	22	70	10	4	●	1
VQMHRBFD1000R200	10	2	22	70	10	4	●	1
VQMHRBFD1200R100	12	1	26	75	12	4	●	1
VQMHRBFD1200R200	12	2	26	75	12	4	●	1
VQMHRBFD1200R300	12	3	26	75	12	4	●	1
VQMHRBFD1600R100	16	1	35	90	16	4	●	1
VQMHRBFD1600R200	16	2	35	90	16	4	●	1

● : Inventory maintained.

SQUARE

BALL

RADIUS

TAPER

BARREL

ROUGHING

RECOMMENDED CUTTING CONDITIONS

Side milling

Work material	P					M					S					N					S				
	Carbon steel, Alloy steel, Mild steel Ck45, 41CrMo4, St44-2, Ck10					Pre-hardened steel, Carbon steel, Alloy steel, Alloy tool steel NAK, X36CrMo17, 40CrNiMoA, X210Cr12, SKT					Hardened stainless steels, Cobalt chromium alloy X5CrNiCuNb16-4, X7CrNiAl17-7					Copper, Copper alloy					Heat resistant alloys Inconel718				
Dia. DC (mm)	Cutting speed (m/min)	Revolution (min ⁻¹)	Feed rate (mm/min)	Depth of cut ap (mm)	Depth of cut ae (mm)	Cutting speed (m/min)	Revolution (min ⁻¹)	Feed rate (mm/min)	Depth of cut ap (mm)	Depth of cut ae (mm)	Cutting speed (m/min)	Revolution (min ⁻¹)	Feed rate (mm/min)	Depth of cut ap (mm)	Depth of cut ae (mm)	Cutting speed (m/min)	Revolution (min ⁻¹)	Feed rate (mm/min)	Depth of cut ap (mm)	Depth of cut ae (mm)	Cutting speed (m/min)	Revolution (min ⁻¹)	Feed rate (mm/min)	Depth of cut ap (mm)	Depth of cut ae (mm)
6	150	8000	2600	9	0.3	120	6400	1300	9	0.3	75	4000	800	9	0.3	180	9500	3000	9	0.3	40	2100	250	9	0.18
8	150	6000	2500	12	0.4	120	4800	1300	12	0.4	75	3000	840	12	0.4	180	7200	3000	12	0.4	40	1600	260	12	0.24
10	150	4800	2300	15	0.5	120	3800	1200	15	0.5	75	2400	770	15	0.5	180	5700	2700	15	0.5	41	1300	290	15	0.3
12	150	4000	1900	18	0.6	120	3200	1200	18	0.6	75	2000	720	18	0.6	180	4800	2300	18	0.6	41	1100	280	18	0.36
16	150	3000	1600	24	0.8	120	2400	960	24	0.8	75	1500	600	24	0.8	180	3600	1900	24	0.8	40	800	200	24	0.48

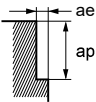

Bottom face milling

Work material	P					M					S					N					S				
	Carbon steel, Alloy steel, Mild steel Ck45, 41CrMo4, St44-2, Ck10					Pre-hardened steel, Carbon steel, Alloy steel, Alloy tool steel NAK, X36CrMo17, 40CrNiMoA, X210Cr12, SKT					Hardened stainless steels, Cobalt chromium alloy X5CrNiCuNb16-4, X7CrNiAl17-7					Copper, Copper alloy					Heat resistant alloys Inconel718				
Dia. DC (mm)	Cutting speed (m/min)	Revolution (min ⁻¹)	Feed rate (mm/min)	Depth of cut ap (mm)	Depth of cut ae (mm)	Cutting speed (m/min)	Revolution (min ⁻¹)	Feed rate (mm/min)	Depth of cut ap (mm)	Depth of cut ae (mm)	Cutting speed (m/min)	Revolution (min ⁻¹)	Feed rate (mm/min)	Depth of cut ap (mm)	Depth of cut ae (mm)	Cutting speed (m/min)	Revolution (min ⁻¹)	Feed rate (mm/min)	Depth of cut ap (mm)	Depth of cut ae (mm)	Cutting speed (m/min)	Revolution (min ⁻¹)	Feed rate (mm/min)	Depth of cut ap (mm)	Depth of cut ae (mm)
6	110	5800	1400	0.3	4.8	90	4800	770	0.3	4.8	55	2900	460	0.3	4.8	130	6900	1700	0.3	4.8	30	1600	180	0.18	4.8
8	110	4400	1200	0.4	6.4	90	3600	720	0.4	6.4	55	2200	440	0.4	6.4	130	5200	1500	0.4	6.4	30	1200	190	0.24	6.4
10	110	3500	1100	0.5	8	90	2900	640	0.5	8	55	1800	400	0.5	8	130	4100	1300	0.5	8	30	950	210	0.3	8
12	110	2900	930	0.6	9.6	90	2400	580	0.6	9.6	55	1500	360	0.6	9.6	130	3400	1100	0.6	9.6	30	800	200	0.36	9.6
16	110	2200	790	0.8	12.8	90	1800	500	0.8	12.8	55	1100	310	0.8	12.8	130	2600	940	0.8	12.8	30	600	150	0.48	12.8

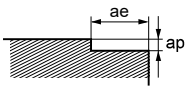

- Note 1) VQ coating has less electrical conductivity; therefore an external contact type (electrically transmitted) tool setter may not work. When measuring the tool length, please use an internal contact type (non-electrical type) tool setter or a laser type tool setter.
- Note 2) Effective cutting of stainless steel, titanium alloys and heat-resistant alloys etc. can be achieved with the use of emulsion coolant.
- Note 3) Chattering can still occur if the machine rigidity and clamping method are insufficient. In these cases the feed and speed should be reduced proportionately.
- Note 4) When the depth of cut is smaller than shown the revolution and feed rate can be increased.

VQ END MILLS

VQHVRB NEW

Corner radius, Short cut length, Irregular helix, 4 flute



Carbon Steel, Alloy Steel, Cast Iron (<30HRC)	Tool Steel, Pre-Hardened Steel, Hardened Steel (≤45HRC)	Hardened Steel (≤55HRC)	Hardened Steel (>55HRC)	Austenitic Stainless Steel	Titanium Alloy, Heat Resistant Alloy	Copper Alloy	Aluminium Alloy
---	---	-------------------------	-------------------------	----------------------------	--------------------------------------	--------------	-----------------

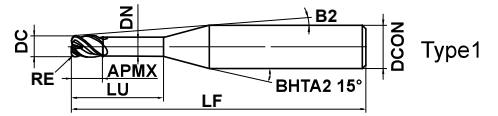

Effective length for inclined angle

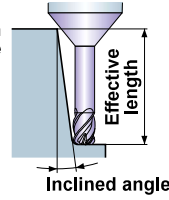

	$0.1 \leq RE \leq 1$				
	± 0.01				
	$1 \leq DC \leq 4$				
	0				
	$- 0.02$				
	$DCON=6$				
	0				
	$- 0.005$				

● SMART MIRACLE corner radius end mill for high feed rates and efficient machining.

(mm)

Order Number	DC	RE	APMX	LU	DN	B2	LF	DCON	Flutes	Stock	Type
VQHVRBD0100R01N080	1	0.1	1	8	0.94	8.2°	50	6	4	●	1
VQHVRBD0100R01N120	1	0.1	1	12	0.94	6.7°	55	6	4	●	1
VQHVRBD0200R02N120	2	0.2	2	12	1.9	5.9°	55	6	4	●	1
VQHVRBD0200R02N160	2	0.2	2	16	1.9	4.9°	60	6	4	●	1
VQHVRBD0300R05N100	3	0.5	3	10	2.9	5.6°	55	6	4	●	1
VQHVRBD0300R05N180	3	0.5	3	18	2.9	3.7°	60	6	4	●	1
VQHVRBD0400R10N120	4	1.0	4	12	3.9	3.9°	55	6	4	●	1
VQHVRBD0400R10N200	4	1.0	4	20	3.9	2.5°	60	6	4	●	1

● : Inventory maintained.

RECOMMENDED CUTTING CONDITIONS

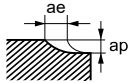
Work material		S									
		Titanium alloys					Hardened stainless steels, Cobalt chromium alloy				
Ti-6Al-4V		X5CrNiCuNb16-4, X7CrNiAl17-7									
Dia. DC (mm)	Neck length LU (mm)	Revolution (min ⁻¹)	Cutting speed (m/min)	Feed rate (mm/min)	Depth of cut ap (mm)	Width of cut ae (mm)	Revolution (min ⁻¹)	Cutting speed (m/min)	Feed rate (mm/min)	Depth of cut ap (mm)	Width of cut ae (mm)
1	8	2500	8	500	0.030	0.1	2500	8	500	0.030	0.1
1	12	2500	8	350	0.030	0.1	2500	8	350	0.030	0.1
2	12	4800	30	600	0.075	0.3	4800	30	600	0.075	0.3
2	16	4800	30	340	0.075	0.3	4800	30	350	0.075	0.3
3	10	8500	80	2400	0.190	1.3	6400	60	2200	0.170	1.3
3	18	8500	80	2000	0.190	1.3	6400	60	1600	0.170	1.3
4	12	6400	80	2000	0.250	1.7	4800	60	1800	0.220	1.7
4	20	6400	80	2000	0.250	1.7	4800	60	1800	0.220	1.7
Depth of cut											

Note 1) VQ coating has less electrical conductivity; therefore an external contact type (electrically transmitted) tool setter may not work.

When measuring the tool length, please use an internal contact type (non-electrical type) tool setter or a laser type tool setter.

Note 2) When cutting titanium alloys, the use of water-soluble cutting fluid is effective.

Note 3) If the depth of cut is shallow, the revolution and feed rate can be increased.

Note 4) The irregular helix flute end mill has a larger effect on controlling vibration when compared to standard end mills.

However, if the rigidity of the machine or the workpiece installation is very low, then vibration can occur.

In this case, please reduce the revolution and feed rate proportionately.

VQ END MILLS

VQ6MHVRBCH

Corner radius end mill. Medium cut length, Irregular helix, 6 flute.
With multiple internal through coolant holes.



Carbon Steel, Alloy Steel, Cast Iron (<30HRC)	Tool Steel, Pre-Hardened Steel, Hardened Steel (≤45HRC)	Hardened Steel (≤55HRC)	Hardened Steel (>55HRC)	Austenitic Stainless Steel	Titanium Alloy, Heat Resistant Alloy	Copper Alloy	Aluminium Alloy
○	○			○	○	○	

CoolStar
END MILLS

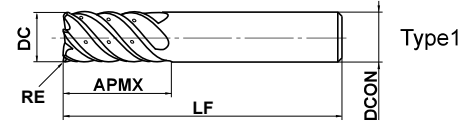

SOLID END MILLS

	0.5 ≤ RE ≤ 4			
	±0.015			
	DC ≤ 12	DC > 12		
	-0.020	-0.030		
	DCON=10	DCON=12	DCON=16	DCON=20
	-0.009	-0.011	-0.011	-0.013

● Vibration control corner radius end mill with multiple internal through coolant holes ensures stable machining on difficult-to-cut materials and applications requiring long overhangs. (mm)

Order Number	DC	RE	APMX	LF	DCON	Flutes	Stock	Type
VQ6MHVRBCHD1000R050	10	0.5	22	70	10	6	●	1
VQ6MHVRBCHD1000R100	10	1	22	70	10	6	●	1
VQ6MHVRBCHD1200R050	12	0.5	26	75	12	6	●	1
VQ6MHVRBCHD1200R100	12	1	26	75	12	6	●	1
VQ6MHVRBCHD1600R100	16	1	32	90	16	6	●	1
VQ6MHVRBCHD1600R300	16	3	32	90	16	6	●	1
VQ6MHVRBCHD1600R400	16	4	32	90	16	6	●	1
VQ6MHVRBCHD2000R100	20	1	38	100	20	6	●	1
VQ6MHVRBCHD2000R300	20	3	38	100	20	6	●	1
VQ6MHVRBCHD2000R400	20	4	38	100	20	6	●	1

SQUARE

BALL

RADIUS

TAPER

BARREL

ROUGHING

● : Inventory maintained.

RECOMMENDED CUTTING CONDITIONS

■ Side milling

Work material	P		M	S	N		S	
	Revolution (min ⁻¹)	Feed rate (mm/min)	Revolution (min ⁻¹)	Feed rate (mm/min)	Revolution (min ⁻¹)	Feed rate (mm/min)	Revolution (min ⁻¹)	Feed rate (mm/min)
Alloy steel, Tool steel, Pre-hardened steel X40CrMoV51			Austenitic Stainless Steel (≤200HB), Titanium Alloy X5CrNi189, X5CrNiMo1810, Ti-6Al-4V		Copper, Copper alloy		Heat Resistant Alloys Inconel 718	
10	—	—	4800	2000	—	—	1300	260
12	—	—	4000	2000	—	—	1100	230
16	4000	2200	3000	1600	2400	1400	800	180
20	3200	1900	2400	1400	1900	1100	640	150
Depth of Cut								

DC: Dia.

■ Trochoidal slotting

Work material	P		M	S
	Revolution (min ⁻¹)	Feed rate (mm/min)	Revolution (min ⁻¹)	Feed rate (mm/min)
Alloy steel, Tool steel, Pre-hardened steel X40CrMoV51			Austenitic stainless steel (≤200HB), Titanium alloy X5CrNi189, X5CrNiMo1810, Ti-6Al-4V	
10	—	—	4800	1400
12	—	—	4000	1200
16	4000	1600	3000	1100
20	3200	1400	2400	900
Depth of cut				

DC: Dia.

Note 1) If the depth of cut is shallow, the revolution and feed rate can be increased.

Note 2) The irregular helix flute end mill has a larger effect on controlling vibration when compared to standard end mills. However, if the rigidity of the machine or the workpiece installation is very low, then vibration can occur. In this case, please reduce the revolution and feed rate proportionately.

VQ END MILLS

VQT5MVRB

Corner radius, Medium cut length, Irregular helix, 5 flute.
With coolant hole.



40°
41.5°
43°



Carbon Steel, Alloy Steel, Cast Iron (<30HRC)	Tool Steel, Pre-Hardened Steel, Hardened Steel (≤45HRC)	Hardened Steel (≤55HRC)	Hardened Steel (>55HRC)	Austenitic Stainless Steel	Titanium Alloy	Copper Alloy	Aluminium Alloy
---	---	-------------------------	-------------------------	----------------------------	----------------	--------------	-----------------

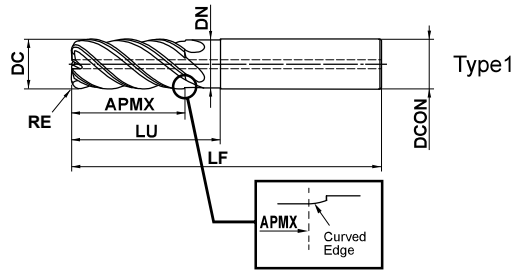

	RE				
	±0.02				
	DC ≤ 16	20 ≤ DC ≤ 25			
	⁰ / _{-0.03}	⁰ / _{-0.04}			
	DCON = 16	20 ≤ DCON ≤ 25			
	⁰ / _{-0.011}	⁰ / _{-0.013}			

- Flute geometry suitable for slot milling.
- The sharp corner radius cutting edges provide long tool life when machining titanium alloys.

(mm)

Order Number	DC	RE	APMX	LU	DN	LF	DCON	Flutes	Stock	Type
VQT5MVRB160R100N48C	16	1	34	48	15.5	120	16	5	●	1
VQT5MVRB160R300N48C	16	3	34	48	15.5	120	16	5	●	1
VQT5MVRB160R400N48C	16	4	34	48	15.5	120	16	5	●	1
VQT5MVRB200R100N60C	20	1	44	60	19.5	135	20	5	●	1
VQT5MVRB200R300N60C	20	3	44	60	19.5	135	20	5	●	1
VQT5MVRB200R400N60C	20	4	44	60	19.5	135	20	5	●	1
VQT5MVRB200R600N60C	20	6	44	60	19.5	135	20	5	●	1
VQT5MVRB250R100N75C	25	1	54	75	24.5	155	25	5	●	1
VQT5MVRB250R300N75C	25	3	54	75	24.5	155	25	5	●	1
VQT5MVRB250R400N75C	25	4	54	75	24.5	155	25	5	●	1
VQT5MVRB250R600N75C	25	6	54	75	24.5	155	25	5	●	1

Note 1) VQ coating has less electrical conductivity; therefore an external contact type (electrically transmitted) tool setter may not work.
When measuring the tool length, please use an internal contact type (non-electrical type) tool setter or a laser type tool setter.
Note 2) Non-standard corner R sizes are available by special orders. Contact us for details.

Special Corner R Size Range

(mm)

DC	RE
16	1-5
20, 25	1-6

● : Inventory maintained.

RECOMMENDED CUTTING CONDITIONS

Shoulder milling

Overhang Length $DC \times 1$ ($DC = \text{Dia.}$)

S						
Work material	Titanium Alloys					
	Ti-6Al-4V etc.					
Dia. DC (mm)	RE	Cutting speed (m/min)	Revolution (min ⁻¹)	Feed rate (mm/min)	Hole Depth ap (mm)	Hole Depth ae (mm)
16	1	80	1600	800	32	2.4
16	3	80	1600	800	32	2.4
16	4	80	1600	800	32	2.4
20	1	80	1300	650	40	3.0
20	3	80	1300	650	40	3.0
20	4	80	1300	650	40	3.0
20	6	80	1300	650	40	3.0
25	1	80	1000	500	50	3.8
25	3	80	1000	500	50	3.8
25	4	80	1000	500	50	3.8
25	6	80	1000	500	50	3.8

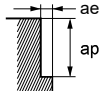
Depth of cut 

Slot milling

Depth of Cut $DC \times 1$

S					
Work material	Titanium Alloys				
	Ti-6Al-4V etc.				
Dia. DC (mm)	RE	Cutting speed (m/min)	Revolution (min ⁻¹)	Feed rate (mm/min)	Hole Depth ap (mm)
16	1	60	1200	420	16
16	3	60	1200	420	16
16	4	60	1200	300	16
20	1	60	950	330	20
20	3	60	950	330	20
20	4	60	950	330	20
20	6	60	950	238	20
25	1	50	640	220	25
25	3	50	640	220	25
25	4	50	640	220	25
25	6	50	640	160	25

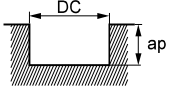
Depth of cut  $DC = \text{Dia.}$

Depth of Cut $DC \times 2$

S					
Work material	Titanium Alloys				
	Ti-6Al-4V etc.				
Dia. DC (mm)	RE	Cutting speed (m/min)	Revolution (min ⁻¹)	Feed rate (mm/min)	Hole Depth ap (mm)
16	1	60	1200	240	32
16	3	60	1200	240	32
16	4	60	1200	180	32
20	1	60	950	190	40
20	3	60	950	190	40
20	4	60	950	190	40
20	6	60	950	143	40
25	1	50	640	130	50
25	3	50	640	130	50
25	4	50	640	130	50
25	6	50	640	96	50

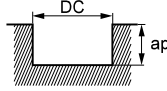
Depth of cut  $DC = \text{Dia.}$

Note 1) VQ coating has less electrical conductivity; therefore an external contact type (electrically transmitted) tool setter may not work.

When measuring the tool length, please use an internal contact type (non-electrical type) tool setter or a laser type tool setter.

Note 2) When cutting titanium alloys, the use of water-soluble cutting fluid is effective.

Note 3) The irregular helix flute end mill has a larger effect on controlling vibration when compared to standard end mills. However, if the rigidity of the machine or the work material installation is poor, vibration or abnormal sound can occur.

In this case, please reduce the revolution and the feed rate proportionately, or set a lower depth of cut.

Note 4) If the depth of cut is smaller, the revolution and the feed rate can be increased.

Note 5) For slot milling, use a chuck with high clamping force.

VQ END MILLS

VQFDRB NEW

Duplex corner radius, For high speed cutting, 4 flute

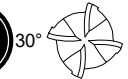

Carbon Steel, Alloy Steel, Cast Iron (<30HRC)	Tool Steel, Pre-Hardened Steel, Hardened Steel (≤45HRC)	Hardened Steel (≤55HRC)	Hardened Steel (>55HRC)	Austenitic Stainless Steel	Titanium Alloy, Heat Resistant Alloy	Copper Alloy	Aluminium Alloy
---	---	-------------------------	-------------------------	----------------------------	--------------------------------------	--------------	-----------------

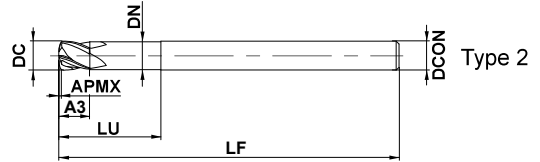
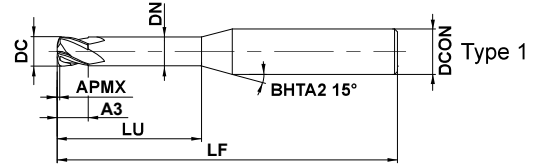
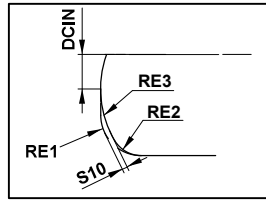

$1 \leq DC \leq 4$				
0				
- 0.020				



DCON=6				
0				
- 0.005				

● Duplex corner radius type allows a more efficient, higher feed.

(mm)

Order Number	DC	RE1	APMX	A3	LU	DN	LF	DCON	Flutes	Multi-radius section				RMPX	Stock	Type
										S10	DCIN	RE2	RE3			
VQFDRBD0300N080	3	0.64	0.18	3	8	2.8	50	6	4	0.08	0.75	0.5	2	2.1°	●	1
VQFDRBD0300N120	3	0.64	0.18	3	12	2.8	55	6	4	0.08	0.75	0.5	2	2.1°	●	1
VQFDRBD0400N120	4	0.71	0.25	4	12	3.8	55	6	4	0.13	1.0	0.5	3	1.9°	●	1
VQFDRBD0400N160	4	0.71	0.25	4	16	3.8	60	6	4	0.13	1.0	0.5	3	1.9°	●	1
VQFDRBD0600N180	6	0.92	0.36	6	18	5.6	60	6	4	0.21	1.5	0.6	5	1.7°	●	2

SOLID END MILLS

SQUARE

BALL

RADIUS

TAPER

BARREL

ROUGHING

● : Inventory maintained.

RECOMMENDED CUTTING CONDITIONS

Work material	S									
	Titanium alloys					Hardened stainless steels, Cobalt chromium alloy				
Dia. DC (mm)	Revolution (min ⁻¹)	Cutting speed (m/min)	Feed rate (mm/min)	Depth of cut ap (mm)	Width of cut ae (mm)	Revolution (min ⁻¹)	Cutting speed (m/min)	Feed rate (mm/min)	Depth of cut ap (mm)	Width of cut ae (mm)
3	8500	80	2100	0.2	1.3	6400	60	3000	0.2	1.3
4	6400	80	2200	0.2	1.7	4800	60	2700	0.2	1.7
6	4200	80	1400	0.3	2.0	3200	60	2100	0.3	2.6

Depth of cut

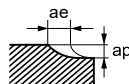

Work material	S				
	Heat resistant alloys				
Dia. DC (mm)	Revolution (min ⁻¹)	Cutting speed (m/min)	Feed rate (mm/min)	Depth of cut ap (mm)	Width of cut ae (mm)
3	3200	30	770	0.2	0.6
4	2400	30	770	0.2	0.8
6	1600	30	520	0.3	1.3

Depth of cut

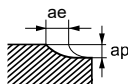

Note 1) VQ coating has less electrical conductivity; therefore an external contact type (electrically transmitted) tool setter may not work.

When measuring the tool length, please use an internal contact type (non-electrical type) tool setter or a laser type tool setter.

Note 2) When cutting titanium alloys, the use of water-soluble cutting fluid is effective.

Note 3) If the depth of cut is shallow, the revolution and feed rate can be increased.

VQ END MILLS

VQT6UR

Barrel, Medium cut length, 6 flute



Carbon Steel, Alloy Steel, Cast Iron (<30HRC)	Tool Steel, Pre-Hardened Steel, Hardened Steel (≤45HRC)	Hardened Steel (≤55HRC)	Hardened Steel (>55HRC)	Austenitic Stainless Steel	Titanium Alloy	Copper Alloy	Aluminium Alloy
○				○	◎		○

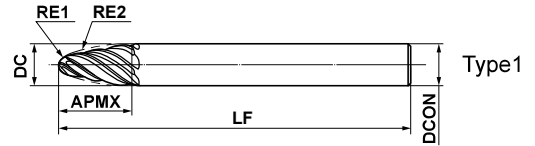

SOLID END MILLS

	RE1 ≤ 4	RE2 ≤ 100			
	±0.01	±0.01			
	DCON ≤ 10	DCON = 12			
	⁰ / _{-0.009}	⁰ / _{-0.011}			

- Nose and tangential form part has two different radii.
- Irregular pitch design prevents chattering.

(mm)

Order Number	DC	RE1	RE2	APMX	LF	DCON	Flutes	Stock	Type
VQT6URR020R075S08	8	2	75	21	90	8	6	●	1
VQT6URR020R085S10	10	2	85	26	100	10	6	●	1
VQT6URR030R075S10	10	3	75	22	100	10	6	●	1
VQT6URR040R100S12	12	4	100	25	110	12	6	●	1

Note 1) VQ coating has less electrical conductivity; therefore an external contact type (electrically transmitted) tool setter may not work. When measuring the tool length, please use an internal contact type (non-electrical type) tool setter or a laser type tool setter.

SQUARE

BALL

RADIUS

TAPER

BARREL

ROUGHING

● : Inventory maintained.

RECOMMENDED CUTTING CONDITIONS

Effective Angle

Please refer to the table below for the use of the nose radius (RE1) and tangential form radius (RE2).

Order Number	Nose Radius		Tangential Form Radius	
	RE1	Effective Angle	RE2	Effective Angle
VQT6URR020R075S08	2	76.6°	75	13.4°
VQT6URR020R085S10	2	74.5°	85	15.5°
VQT6URR030R075S10	3	76.4°	75	13.6°
VQT6URR040R100S12	4	78.3°	100	11.7°

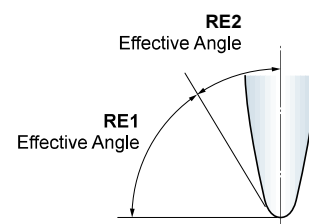

Side Milling with the Use of the Tangential Form Radius (RE2)

Work Material	P			M	S	N				
	Mild Steels ($\leq 180\text{HB}$) Carbon Steels, Cast Irons (180—280HB)			Austenitic Stainless Steels ($\leq 200\text{HB}$) Titanium Alloys		Aluminium Alloys ($\text{Si} < 5\%$)				
DC	RE2	Revolution (min ⁻¹)	Feed rate (mm/min)	Depth of cut ap	Revolution (min ⁻¹)	Feed rate (mm/min)	Depth of cut ap	Revolution (min ⁻¹)	Feed rate (mm/min)	Depth of cut ap
8	75	8000	2400	0.05—0.3	3200	770	0.05—0.3	16000	4800	0.05—0.3
10	85	6400	1900	0.05—0.3	2500	600	0.05—0.3	13000	3900	0.05—0.3
10	75	6400	1900	0.05—0.3	2500	600	0.05—0.3	13000	3900	0.05—0.3
12	100	5300	1600	0.05—0.3	2100	500	0.05—0.3	11000	3300	0.05—0.3

Depth of Cut Calculation Table Based on Tangential Form Radius (RE2) and Cusp Height (h)

Work Material	RE2	Cusp Height h	0.0001	0.0003	0.0005	0.0008	0.001	0.003	0.005	0.008
VQT6URR020R075S08	75	Depth of Cut ae	0.245	0.424	0.548	0.693	0.775	1.342	1.732	2.191
VQT6URR030R075S10	75		0.245	0.424	0.548	0.693	0.775	1.342	1.732	2.191
VQT6URR020R085S10	85		0.261	0.452	0.583	0.738	0.825	1.428	1.844	2.332
VQT6URR040R100S12	100		0.283	0.49	0.632	0.8	0.894	1.549	2	2.53

Note 1) VQ coating has less electrical conductivity; therefore an external contact type (electrically transmitted) tool setter may not work.

When measuring the tool length, please use an internal contact type (non-electrical type) tool setter or a laser type tool setter.

Note 2) It is recommended to use this tool only for finish cutting.

Note 3) The tool contact part differs between the nose radius and tangential form radius depending on machining geometries and tilt angles.

Select suitable cutting conditions according to tool contact parts.

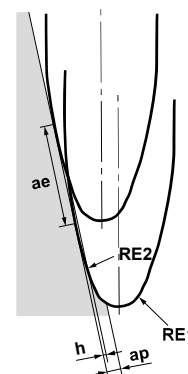

VQ END MILLS

VQT6UR

Barrel, Medium cut length, 6 flute

CARBIDE

SOLID END MILLS

SQUARE

BALL

RADIUS

TAPER

BARREL

ROUGHING

Slot Milling with the Use of the Nose Radius (RE1)

(mm)

Work Material		P				M		S		N			
		Mild Steels ($\leq 180\text{HB}$) Carbon Steels, Cast Irons (180–280HB)				Austenitic Stainless Steels ($\leq 200\text{HB}$) Titanium Alloys		Aluminium Alloys (Si < 5%)					
DC	RE2	Revolution (min ⁻¹)	Feed rate (mm/min)	Depth of cut ap	Depth of cut ae	Revolution (min ⁻¹)	Feed rate (mm/min)	Depth of cut ap	Depth of cut ae	Revolution (min ⁻¹)	Feed rate (mm/min)	Depth of cut ap	Depth of cut ae
8	2	16000	2400	0.4	1	6400	580	0.4	1	32000	4800	0.4	1
10	2	16000	2400	0.4	1	6400	580	0.4	1	32000	4800	0.4	1
10	3	11000	1700	0.6	1.5	4200	380	0.6	1.5	21000	3200	0.6	1.5
12	4	8000	1200	0.8	2	3200	290	0.8	2	16000	2400	0.8	2

Note 1) VQ coating has less electrical conductivity; therefore an external contact type (electrically transmitted) tool setter may not work.

When measuring the tool length, please use an internal contact type (non-electrical type) tool setter or a laser type tool setter.

Note 2) It is recommended to use this tool only for finish cutting.

Note 3) The tool contact part differs between the nose radius and tangential form radius depending on machining geometries and tilt angles.

Select suitable cutting conditions according to tool contact parts.

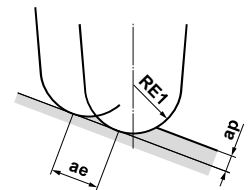

ae: Pick feed

VQSVR

Roughing end mill, Short cut length, Irregular helix, 3/4 flutes



CARBIDE

Carbon Steel, Alloy Steel, Cast Iron (<30HRC)	Tool Steel, Pre-Hardened Steel, Hardened Steel (≤45HRC)	Hardened Steel (≤55HRC)	Hardened Steel (>55HRC)	Austenitic Stainless Steel	Titanium Alloy, Heat Resistant Alloy	Copper Alloy	Aluminium Alloy
○	○			○	○	○	

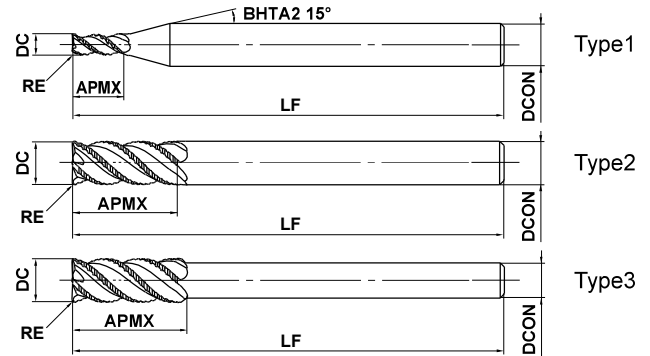

h6	DCON=6	8 ≤ DCON ≤ 10	12 ≤ DCON ≤ 16	DCON=20
	0 - 0.008	0 - 0.009	0 - 0.011	0 - 0.013

● Achieves excellent vibration resistance due to the adoption of irregular helix flutes.

(mm)

Order Number	DC	RE	APMX	LF	DCON	Flutes	Stock	Type
VQSVRD0300	3	0.2	6	60	6	3	●	1
VQSVRD0400	4	0.2	8	60	6	3	●	1
VQSVRD0500	5	0.3	10	60	6	3	●	1
VQSVRD0600	6	0.3	12	70	6	3	●	2
VQSVRD0700	7	0.3	17	80	8	3	●	1
VQSVRD0800	8	0.5	17	80	8	4	●	2
VQSVRD0900	9	0.5	22	90	10	4	●	1
VQSVRD1000S08	10	0.5	22	90	8	4	●	3
VQSVRD1000	10	0.5	22	90	10	4	●	2
VQSVRD1200S10	12	0.5	27	100	10	4	●	3
VQSVRD1200	12	0.5	27	100	12	4	●	2
VQSVRD1400	14	0.5	27	130	12	4	●	3
VQSVRD1600	16	0.5	33	125	16	4	●	2
VQSVRD1800	18	0.5	33	150	16	4	●	3
VQSVRD2000	20	0.5	38	140	20	4	●	2

SOLID END MILLS

SQUARE

BALL

RADIUS

TAPER

BARREL

ROUGHING

● : Inventory maintained.

VQ END MILLS

VQSVR

Roughing end mill, Short cut length, Irregular helix, 3/4 flutes

CARBIDE

SOLID END MILLS

SQUARE

BALL

RADIUS

TAPER

BARREL

ROUGHING

RECOMMENDED CUTTING CONDITIONS

■ Side milling

When machine and work material rigidity and chip discharge properties are sufficient, please select the high efficiency cutting conditions.
When machine rigidity, work material rigidity or chip discharge properties are insufficient, please select general-purpose cutting conditions.

High efficiency cutting conditions

Work material	P										M		S		M		S		N						
	Carbon steel, Alloy steel, Mild steel					Pre-hardened steel, Carbon steel, Alloy steel, Alloy tool steel					Austenitic, Ferritic and Martensitic stainless steels, Titanium alloys					Hardened stainless steels, Cobalt chromium alloy					Copper, Copper alloy				
	Ck45, 41CrMo4, St44-2, Ck10					NAK, X36CrMo17, 40CrNiMoA, X210Cr12, SKT					X5CrNi189, X8CrNiMo173, Ti6Al4V					X5CrNiCuNb16-4, X7CrNiAl17-7									
Dia. DC (mm)	Cutting speed (mm/min)	Revolution (min ⁻¹)	Feed rate (mm/min)	Hole Depth ap (mm)	Hole Depth ae (mm)	Cutting speed (mm/min)	Revolution (min ⁻¹)	Feed rate (mm/min)	Hole Depth ap (mm)	Hole Depth ae (mm)	Cutting speed (mm/min)	Revolution (min ⁻¹)	Feed rate (mm/min)	Hole Depth ap (mm)	Hole Depth ae (mm)	Cutting speed (mm/min)	Revolution (min ⁻¹)	Feed rate (mm/min)	Hole Depth ap (mm)	Hole Depth ae (mm)	Cutting speed (mm/min)	Revolution (min ⁻¹)	Feed rate (mm/min)	Hole Depth ap (mm)	Hole Depth ae (mm)
3	150	16000	960	4.5	1.5	120	13000	640	4.5	1.5	100	11000	450	4.5	1.5	75	8000	330	4.5	0.9	180	19000	1100	4.5	1.5
4	150	12000	960	6	2	120	9500	640	6	2	100	8000	430	6	2	75	6000	330	6	1.2	180	14000	1100	6	2
5	150	9500	960	7.5	2.5	120	7600	640	7.5	2.5	100	6400	440	7.5	2.5	75	4800	330	7.5	1.5	180	11000	1100	7.5	2.5
6	150	8000	960	9	3	120	6400	680	9	3	100	5300	480	9	3	75	4000	360	9	1.8	180	9500	1100	9	3
7	150	6800	950	10.5	3.5	120	5500	700	10.5	3.5	100	4500	500	10.5	3.5	75	3400	380	10.5	2.1	180	8200	1100	10.5	3.5
8	150	6000	1100	12	4	120	4800	800	12	4	100	4000	570	12	4	75	3000	430	12	2.4	180	7200	1300	12	4
9	150	5300	1100	13.5	4.5	120	4200	760	13.5	4.5	100	3500	570	13.5	4.5	75	2700	430	13.5	2.7	180	6400	1300	13.5	4.5
10	150	4800	1100	15	5	120	3800	760	15	5	100	3200	570	15	5	75	2400	430	15	3	180	5700	1200	15	5
12	150	4000	960	18	6	120	3200	700	18	6	100	2700	540	18	6	75	2000	400	18	3.6	180	4800	1200	18	6
14	150	3400	880	21	7	120	2700	650	21	7	100	2300	510	21	7	75	1700	380	21	4.2	180	4100	1100	21	7
16	150	3000	840	24	8	120	2400	620	24	8	100	2000	500	24	8	75	1500	380	24	4.8	180	3600	1000	24	8
18	150	2700	810	27	9	120	2100	590	27	9	100	1800	500	27	9	75	1300	360	27	5.4	180	3200	960	27	9
20	150	2400	760	30	10	120	1900	560	30	10	100	1600	500	30	10	75	1200	360	30	6	180	2900	920	30	10

Depth of cut

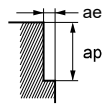

General purpose cutting conditions

Work material	P										M		S		M		S		N						
	Carbon steel, Alloy steel, Mild steel					Pre-hardened steel, Carbon steel, Alloy steel, Alloy tool steel					Austenitic, Ferritic and Martensitic stainless steels, Titanium alloys					Hardened stainless steels, Cobalt chromium alloy					Copper, Copper alloy				
	Ck45, 41CrMo4, St44-2, Ck10					NAK, X36CrMo17, 40CrNiMoA, X210Cr12, SKT					X5CrNi189, X8CrNiMo173, Ti6Al4V					X5CrNiCuNb16-4, X7CrNiAl17-7									
Dia. DC (mm)	Cutting speed (mm/min)	Revolution (min ⁻¹)	Feed rate (mm/min)	Hole Depth ap (mm)	Hole Depth ae (mm)	Cutting speed (mm/min)	Revolution (min ⁻¹)	Feed rate (mm/min)	Hole Depth ap (mm)	Hole Depth ae (mm)	Cutting speed (mm/min)	Revolution (min ⁻¹)	Feed rate (mm/min)	Hole Depth ap (mm)	Hole Depth ae (mm)	Cutting speed (mm/min)	Revolution (min ⁻¹)	Feed rate (mm/min)	Hole Depth ap (mm)	Hole Depth ae (mm)	Cutting speed (mm/min)	Revolution (min ⁻¹)	Feed rate (mm/min)	Hole Depth ap (mm)	Hole Depth ae (mm)
3	120	13000	610	4.5	1.5	100	11000	430	4.5	1.5	80	8500	280	4.5	1.5	70	7400	240	4.5	0.9	140	15000	700	4.5	1.5
4	120	9500	610	6	2	100	8000	430	6	2	80	6400	280	6	2	70	5600	240	6	1.2	140	11000	700	6	2
5	120	7600	610	7.5	2.5	100	6400	430	7.5	2.5	80	5100	280	7.5	2.5	70	4500	250	7.5	1.5	140	8900	720	7.5	2.5
6	120	6400	610	9	3	100	5300	450	9	3	80	4200	300	9	3	70	3700	270	9	1.8	140	7400	720	9	3
7	120	5500	620	10.5	3.5	100	4500	480	10.5	3.5	80	3600	320	10.5	3.5	70	3200	290	10.5	2.1	140	6400	720	10.5	3.5
8	120	4800	720	12	4	100	4000	570	12	4	80	3200	380	12	4	70	2800	340	12	2.4	140	5600	840	12	4
9	120	4200	670	13.5	4.5	100	3500	510	13.5	4.5	80	2800	360	13.5	4.5	70	2500	320	13.5	2.7	140	5000	800	13.5	4.5
10	120	3800	670	15	5	100	3200	510	15	5	80	2500	360	15	5	70	2200	310	15	3	140	4500	790	15	5
12	120	3200	610	18	6	100	2700	470	18	6	80	2100	340	18	6	70	1900	300	18	3.6	140	3700	710	18	6
14	120	2700	560	21	7	100	2300	440	21	7	80	1800	320	21	7	70	1600	280	21	4.2	140	3200	670	21	7
16	120	2400	540	24	8	100	2000	410	24	8	80	1600	320	24	8	70	1400	280	24	4.8	140	2800	630	24	8
18	120	2100	500	27	9	100	1800	400	27	9	80	1400	310	27	9	70	1200	270	27	5.4	140	2500	600	27	9
20	120	1900	480	30	10	100	1600	380	30	10	80	1300	310	30	10	70	1100	270	30	6	140	2200	560	30	10

Depth of cut

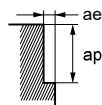

- Note 1) VQ coating has less electrical conductivity; therefore an external contact type (electrically transmitted) tool setter may not work.
When measuring the tool length, please use an internal contact type (non-electrical type) tool setter or a laser type tool setter.
Note 2) Effective cutting of stainless steel, titanium alloys and heat-resistant alloys etc. can be achieved with the use of emulsion coolant.
Note 3) Chattering can still occur if the machine rigidity and clamping method are insufficient.
In these cases the feed and speed should be reduced proportionately.
Note 4) When the depth of cut is smaller than shown the revolution and feed rate can be increased.

■ Slotting

When machine and work material rigidity and chip discharge properties are sufficient, please select the high efficiency cutting conditions.
When machine rigidity, work material rigidity or chip discharge properties are insufficient, please select general-purpose cutting conditions.

High efficiency cutting conditions

Work material	P				M				S				M				S				N			
	Carbon steel, Alloy steel, Mild steel				Pre-hardened steel, Carbon steel, Alloy steel, Alloy tool steel				Austenitic, Ferritic and Martensitic stainless steels, Titanium alloys				Hardened stainless steels, Cobalt chromium alloy				Copper, Copper alloy							
	Ck45, 41CrMo4, St44-2, Ck10				NAK, X36CrMo17, 40CrNiMoA, X210Cr12, SKT				X5CrNi189, X8CrNiMo173, Ti6Al4V				X5CrNiCuNb16-4, X7CrNiAl17-7											
Dia. DC (mm)	Cutting speed (m/min)	Revolution (min ⁻¹)	Feed rate (mm/min)	Depth of cut ap (mm)	Cutting speed (m/min)	Revolution (min ⁻¹)	Feed rate (mm/min)	Depth of cut ap (mm)	Cutting speed (m/min)	Revolution (min ⁻¹)	Feed rate (mm/min)	Depth of cut ap (mm)	Cutting speed (m/min)	Revolution (min ⁻¹)	Feed rate (mm/min)	Depth of cut ap (mm)	Cutting speed (m/min)	Revolution (min ⁻¹)	Feed rate (mm/min)	Depth of cut ap (mm)				
3	120	13000	720	3	100	11000	440	3	80	8500	340	3	60	6400	250	1.5	150	16000	890	3				
4	120	9500	720	4	100	8000	450	4	80	6400	340	4	60	4800	250	2	150	12000	900	4				
5	120	7600	720	5	100	6400	460	5	80	5100	300	5	60	3800	230	2.5	150	9500	900	5				
6	120	6400	720	6	100	5300	460	6	80	4200	310	6	60	3200	240	3	150	8000	900	6				
7	120	5500	730	7	100	4500	470	7	80	3600	330	7	60	2700	250	3.5	150	6800	950	7				
8	120	4800	840	8	100	4000	560	8	80	3200	400	8	60	2400	300	4	150	6000	1100	8				
9	120	4200	810	9	100	3500	540	9	80	2800	350	9	60	2100	260	4.5	150	5300	1000	9				
10	120	3800	800	10	100	3200	520	10	80	2500	340	10	60	1900	260	5	150	4800	1000	10				
12	120	3200	750	12	100	2700	480	12	80	2100	340	12	60	1600	260	6	150	4000	940	12				
14	120	2700	670	14	100	2300	420	14	80	1800	300	14	60	1400	240	7	150	3400	840	14				
16	120	2400	620	16	100	2000	380	16	80	1600	290	16	60	1200	220	8	150	3000	780	16				
18	120	2100	570	18	100	1800	380	18	80	1400	260	18	60	1100	210	9	150	2700	730	18				
20	120	1900	540	20	100	1600	350	20	80	1300	260	20	60	950	190	10	150	2400	680	20				

DC: Dia.

General purpose cutting conditions

Work material	P				M				S				M				S				N			
	Carbon steel, Alloy steel, Mild steel				Pre-hardened steel, Carbon steel, Alloy steel, Alloy tool steel				Austenitic, Ferritic and Martensitic stainless steels, Titanium alloys				Hardened stainless steels, Cobalt chromium alloy				Copper, Copper alloy							
	Ck45, 41CrMo4, St44-2, Ck10				NAK, X36CrMo17, 40CrNiMoA, X210Cr12, SKT				X5CrNi189, X8CrNiMo173, Ti6Al4V				X5CrNiCuNb16-4, X7CrNiAl17-7											
Dia. DC (mm)	Cutting speed (m/min)	Revolution (min ⁻¹)	Feed rate (mm/min)	Depth of cut ap (mm)	Cutting speed (m/min)	Revolution (min ⁻¹)	Feed rate (mm/min)	Depth of cut ap (mm)	Cutting speed (m/min)	Revolution (min ⁻¹)	Feed rate (mm/min)	Depth of cut ap (mm)	Cutting speed (m/min)	Revolution (min ⁻¹)	Feed rate (mm/min)	Depth of cut ap (mm)	Cutting speed (m/min)	Revolution (min ⁻¹)	Feed rate (mm/min)	Depth of cut ap (mm)				
3	100	11000	490	3	80	8500	300	3	60	6400	200	3	50	5300	170	1.5	120	13000	580	3				
4	100	8000	490	4	80	6400	310	4	60	4800	200	4	50	4000	170	2	120	9500	580	4				
5	100	6400	490	5	80	5100	310	5	60	3800	200	5	50	3200	170	2.5	120	7600	580	5				
6	100	5300	490	6	80	4200	310	6	60	3200	200	6	50	2700	170	3	120	6400	580	6				
7	100	4500	500	7	80	3600	320	7	60	2700	200	7	50	2300	170	3.5	120	5500	620	7				
8	100	4000	600	8	80	3200	380	8	60	2400	240	8	50	2000	200	4	120	4800	720	8				
9	100	3500	540	9	80	2800	330	9	60	2100	210	9	50	1800	180	4.5	120	4200	650	9				
10	100	3200	540	10	80	2500	330	10	60	1900	210	10	50	1600	180	5	120	3800	640	10				
12	100	2700	510	12	80	2100	320	12	60	1600	210	12	50	1300	170	6	120	3200	600	12				
14	100	2300	460	14	80	1800	300	14	60	1400	190	14	50	1100	150	7	120	2700	540	14				
16	100	2000	410	16	80	1600	290	16	60	1200	170	16	50	990	140	8	120	2400	500	16				
18	100	1800	390	18	80	1400	260	18	60	1100	170	18	50	880	130	9	120	2100	460	18				
20	100	1600	360	20	80	1300	260	20	60	950	150	20	50	800	130	10	120	1900	430	20				

DC: Dia.

- Note 1) VQ coating has less electrical conductivity; therefore an external contact type (electrically transmitted) tool setter may not work. When measuring the tool length, please use an internal contact type (non-electrical type) tool setter or a laser type tool setter.
- Note 2) Effective cutting of stainless steel, titanium alloys and heat-resistant alloys etc. can be achieved with the use of emulsion coolant.
- Note 3) Chattering can still occur if the machine rigidity and clamping method are insufficient. In these cases the feed and speed should be reduced proportionately.
- Note 4) When the depth of cut is smaller than shown the revolution and feed rate can be increased.

I
 SOLID END MILLS
 SQUARE
 BALL
 RADIUS
 TAPER
 BARREL
 ROUGHING

CERAMIC END MILLS

CE4SRB/CE6SRB

Corner radius end mill, Short cut length, 4/6 flutes



Carbon Steel, Alloy Steel, Cast Iron (<30HRC)	Tool Steel, Pre-Hardened Steel, Hardened Steel (≤45HRC)	Hardened Steel (≤55HRC)	Hardened Steel (>55HRC)	Austenitic Stainless Steel	Heat Resistant Alloy	Copper Alloy	Aluminium Alloy
---	---	-------------------------	-------------------------	----------------------------	----------------------	--------------	-----------------

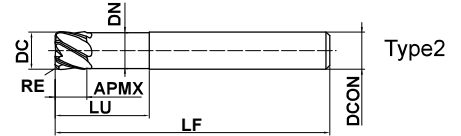
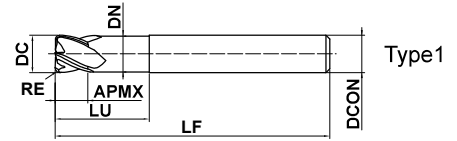

SOLID END MILLS



DC ≤ 12				
±0.02				



DC=6	DC=8,10	DC=12		
- 0.008 - 0.028	- 0.009 - 0.029	- 0.011 - 0.031		



D CON=6	D CON=8,10	D CON=12		
0 - 0.008	0 - 0.009	0 - 0.011		

- Ceramic corner radius end mill with extreme resistance to heat.
- Capable of softening Ni based alloys by generating heat during machining

(mm)

Order Number	DC	RE	APMX	LU	DN	LF	D CON	Flutes	Stock	Type
CE4SRBD0600R050	6	0.5	4.5	12	5.85	50	6	4	●	1
CE4SRBD0800R100	8	1.0	6.0	16	7.85	60	8	4	●	1
CE4SRBD1000R100	10	1.0	7.5	20	9.70	65	10	4	●	1
CE4SRBD1200R150	12	1.5	9.0	24	11.70	70	12	4	●	1
CE6SRBD0600R050	6	0.5	4.5	12	5.85	50	6	6	●	2
CE6SRBD0800R100	8	1.0	6.0	16	7.85	60	8	6	●	2
CE6SRBD1000R100	10	1.0	7.5	20	9.70	65	10	6	●	2
CE6SRBD1200R150	12	1.5	9.0	24	11.70	70	12	6	●	2

Note 1) Do not use on titanium alloys

SQUARE

BALL

RADIUS

TAPER

BARREL

ROUGHING

● : Inventory maintained.

CE4SRB

Corner radius end mill, Short cut length, 4 flute

CARBIDE

RECOMMENDED CUTTING CONDITIONS

Side milling

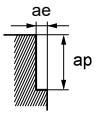
S				
Work material	Inconel			
Dia. DC (mm)	Cutting speed (m/min)	Feed per tooth (mm/t)	Depth of cut ap (mm)	Depth of cut ae (mm)
6	≥ 350	≤ 0.06	≤ 4.5	≤ 1.2
8	≥ 350	≤ 0.06	≤ 6.0	≤ 1.6
10	≥ 350	≤ 0.06	≤ 7.5	≤ 2.0
12	≥ 350	≤ 0.06	≤ 9.0	≤ 2.4
Depth of cut				DC: Dia.

Slotting

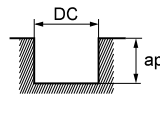
S			
Work material	Inconel		
Dia. DC (mm)	Cutting speed (m/min)	Feed per tooth (mm/t)	Depth of cut ap (mm)
6	≥ 350	≤ 0.03	≤ 1.5
8	≥ 350	≤ 0.03	≤ 1.5
10	≥ 350	≤ 0.03	≤ 2.0
12	≥ 350	≤ 0.03	≤ 2.5
Depth of cut			DC: Dia.

Note 1) The outermost layer of the material may be affected by heat. Ensure a minimum of 0.3 mm final machining allowance remains.

Note 2) The recommended ramping angle is 1.5°. For ramping it is recommended to reduce the feed by 50%.

Note 3) Gradually increase the width of cut (ae) starting from 0.05 x DC.

SOLID END MILLS

SQUARE

BALL

RADIUS

TAPER

BARREL

ROUGHING

CE6SRB

Corner radius end mill, Short cut length, 6 flute

RECOMMENDED CUTTING CONDITIONS

Side milling

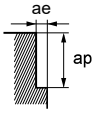
S				
Work material	Inconel			
Dia. DC (mm)	Cutting speed (m/min)	Feed per tooth (mm/t)	Depth of cut ap (mm)	Depth of cut ae (mm)
6	≥ 350	≤ 0.06	≤ 4.5	≤ 1.2
8	≥ 350	≤ 0.06	≤ 6.0	≤ 1.6
10	≥ 350	≤ 0.06	≤ 7.5	≤ 2.0
12	≥ 350	≤ 0.06	≤ 9.0	≤ 2.4
Depth of cut				DC: Dia.

Note 1) The outermost layer of the material may be affected by heat. Ensure a minimum of 0.3 mm final machining allowance remains.

Note 2) The recommended ramping angle is 1.5°. For ramping it is recommended to reduce the feed by 50%.

Note 3) Gradually increase the width of cut (ae) starting from 0.05 x DC.

CRN COATED END MILLS

CRN2MB

Ball nose, Medium cut length, For copper electrodes, 2 flute



Carbon Steel, Alloy Steel, Cast Iron (<30HRC)	Tool Steel, Pre-Hardened Steel, Hardened Steel (≤45HRC)	Hardened Steel (≤55HRC)	Hardened Steel (>55HRC)	Austenitic Stainless Steel	Titanium Alloy, Heat Resistant Alloy	Copper Alloy	Aluminium Alloy
						○	○

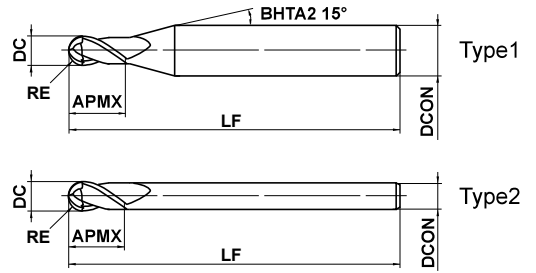

SOLID END MILLS

	$0.2 \leq RE \leq 5$				
	± 0.01				
	$0.4 \leq DC \leq 10$				
	0 $- 0.02$				
	$4 \leq DCON \leq 6$	$8 \leq DCON \leq 10$			
	0 $- 0.008$	0 $- 0.009$			

● 2 flute ball nose end mill with CRN coating for copper electrode machining.

(mm)

Order Number	RE	DC	APMX	LF	DCON	Flutes	Stock	Type
CRN2MBR0020S04	0.2	0.4	0.8	45	4	2	●	1
CRN2MBR0030S04	0.3	0.6	1.2	45	4	2	●	1
CRN2MBR0040S04	0.4	0.8	1.6	45	4	2	●	1
CRN2MBR0050S04	0.5	1	2.5	45	4	2	●	1
CRN2MBR0050S06	0.5	1	2.5	50	6	2	●	1
CRN2MBR0075S04	0.75	1.5	4	45	4	2	●	1
CRN2MBR0100S06	1	2	6	50	6	2	●	1
CRN2MBR0150S06	1.5	3	8	70	6	2	●	1
CRN2MBR0200S06	2	4	8	70	6	2	●	1
CRN2MBR0300S06	3	6	12	80	6	2	●	2
CRN2MBR0400S08	4	8	14	90	8	2	●	2
CRN2MBR0500S10	5	10	18	100	10	2	●	2

SQUARE

BALL

RADIUS

TAPER

BARREL

ROUGHING

● : Inventory maintained.

RECOMMENDED CUTTING CONDITIONS

Work material	N				Depth of cut ap (mm)
	Copper, Copper alloys				
	$\alpha \leq 15^\circ$		$\alpha > 15^\circ$		
RE (mm)	Revolution (min ⁻¹)	Feed rate (mm/min)	Revolution (min ⁻¹)	Feed rate (mm/min)	
R0.2	40000	1600	40000	1200	0.02
R0.3	40000	3200	40000	1600	0.03
R0.4	40000	6400	40000	2400	0.05
R0.5	40000	8000	40000	3200	0.06
R0.75	40000	9600	40000	4000	0.09
R1	40000	9600	39000	4700	0.11
R1.25	40000	12000	30000	4500	0.12
R1.5	40000	12000	27000	4300	0.13
R2	32000	11000	20000	3600	0.15
R2.5	25000	9000	16000	2900	0.20
R3	21000	8400	13000	2600	0.25
R4	16000	6400	10000	2000	0.30
R5	13000	5200	8000	1700	0.50
R6	9000	3600	6000	1300	0.50

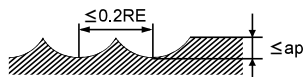

RE:Radius

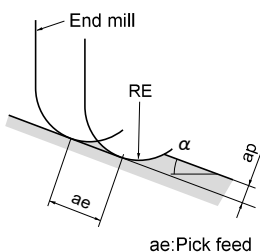

ae:Pick feed

Note 1) α is the inclination angle of the machined surface.

Note 2) If the depth of cut is shallow, the revolution and feed rate can be increased.

Note 3) Water-soluble cutting fluid is recommended.

Note 4) If the rigidity of the machine or the work materials installation is very low, or chattering and noise are generated, reduce the revolution and feed rate proportionately.

CRN COATED END MILLS

CRN2XLB

Ball nose, Long neck, For copper electrodes, 2 flute



Carbon Steel, Alloy Steel, Cast Iron (<30HRC)	Tool Steel, Pre-Hardened Steel, Hardened Steel (≤45HRC)	Hardened Steel (≤55HRC)	Hardened Steel (>55HRC)	Austenitic Stainless Steel	Titanium Alloy, Heat Resistant Alloy	Copper Alloy	Aluminium Alloy
---	---	-------------------------	-------------------------	----------------------------	--------------------------------------	--------------	-----------------

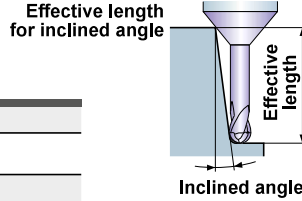
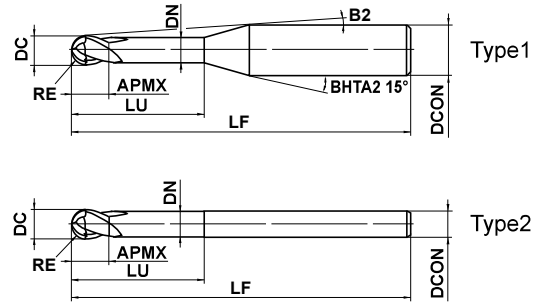

	0.15 ≤ RE ≤ 3		
	±0.01		
	0.3 ≤ DC ≤ 6		
	0		
	- 0.02		
	4 ≤ DCON ≤ 6		
	0		
	- 0.008		

● 2 flute long neck ball nose end mill with CRN coating for copper electrode machining.

(mm)

Order Number	RE	DC	APMX	LU	DN	B2	LF	DCON	Flutes	Stock	Type	Effective length for inclined angle			
												0.5°	1°	2°	3°
CRN2XLB0015N010S04	0.15	0.3	0.3	1	0.27	13.3°	50	4	2	●	1	1	1.1	1.2	1.3
CRN2XLB0015N015S04	0.15	0.3	0.3	1.5	0.27	12.5°	50	4	2	●	1	1.5	1.6	1.7	1.9
CRN2XLB0015N020S04	0.15	0.3	0.3	2	0.27	11.9°	50	4	2	●	1	2.1	2.2	2.3	2.5
CRN2XLB0020N010S04	0.2	0.4	0.4	1	0.36	13.4°	50	4	2	●	1	1	1	1.1	1.2
CRN2XLB0020N015S04	0.2	0.4	0.4	1.5	0.36	12.6°	50	4	2	●	1	1.5	1.6	1.7	1.8
CRN2XLB0020N020S04	0.2	0.4	0.4	2	0.36	11.9°	50	4	2	●	1	2	2.1	2.3	2.5
CRN2XLB0020N030S04	0.2	0.4	0.4	3	0.36	10.7°	50	4	2	●	1	3.1	3.2	3.4	3.7
CRN2XLB0025N015S04	0.25	0.5	0.5	1.5	0.46	12.6°	50	4	2	●	1	1.5	1.6	1.7	1.8
CRN2XLB0025N020S04	0.25	0.5	0.5	2	0.46	11.9°	50	4	2	●	1	2	2.1	2.3	2.4
CRN2XLB0025N030S04	0.25	0.5	0.5	3	0.46	10.6°	50	4	2	●	1	3.1	3.2	3.4	3.7
CRN2XLB0025N030S06	0.25	0.5	0.5	3	0.46	11.9°	50	6	2	●	1	3.1	3.2	3.4	3.7
CRN2XLB0025N040S04	0.25	0.5	0.5	4	0.46	9.6°	50	4	2	●	1	4.1	4.3	4.6	4.9
CRN2XLB0025N060S04	0.25	0.5	0.5	6	0.46	8.1°	50	4	2	●	1	6.2	6.4	6.9	7.4
CRN2XLB0025N080S04	0.25	0.5	0.5	8	0.46	7°	50	4	2	●	1	8.3	8.5	9.2	9.9
CRN2XLB0030N020S04	0.3	0.6	0.6	2	0.56	11.8°	50	4	2	●	1	2.1	2.2	2.3	2.5
CRN2XLB0030N040S04	0.3	0.6	0.6	4	0.56	9.5°	50	4	2	●	1	4.2	4.3	4.6	5
CRN2XLB0030N060S04	0.3	0.6	0.6	6	0.56	8°	50	4	2	●	1	6.3	6.5	6.9	7.5
CRN2XLB0030N080S04	0.3	0.6	0.6	8	0.56	6.9°	50	4	2	●	1	8.3	8.6	9.2	10
CRN2XLB0030N100S04	0.3	0.6	0.6	10	0.56	6°	50	4	2	●	1	10.4	10.8	11.5	12.5
CRN2XLB0040N020S04	0.4	0.8	0.8	2	0.76	11.7°	50	4	2	●	1	2.1	2.2	2.3	2.5
CRN2XLB0040N040S04	0.4	0.8	0.8	4	0.76	9.4°	50	4	2	●	1	4.2	4.3	4.6	5
CRN2XLB0040N060S04	0.4	0.8	0.8	6	0.76	7.8°	50	4	2	●	1	6.3	6.5	6.9	7.5
CRN2XLB0040N080S04	0.4	0.8	0.8	8	0.76	6.7°	50	4	2	●	1	8.3	8.6	9.2	10
CRN2XLB0040N100S04	0.4	0.8	0.8	10	0.76	5.9°	50	4	2	●	1	10.4	10.8	11.5	12.4
CRN2XLB0050N030S04	0.5	1	1	3	0.94	10.1°	50	4	2	●	1	3.2	3.3	3.6	3.9
CRN2XLB0050N040S04	0.5	1	1	4	0.94	9.1°	50	4	2	●	1	4.2	4.4	4.8	5.2
CRN2XLB0050N050S04	0.5	1	1	5	0.94	8.2°	50	4	2	●	1	5.3	5.5	6	6.4
CRN2XLB0050N050S06	0.5	1	1	5	0.94	10.1°	50	6	2	●	1	5.3	5.5	6	6.4
CRN2XLB0050N060S04	0.5	1	1	6	0.94	7.5°	50	4	2	●	1	6.3	6.6	7.1	7.7
CRN2XLB0050N060S06	0.5	1	1	6	0.94	9.4°	50	6	2	●	1	6.3	6.6	7.1	7.7
CRN2XLB0050N080S04	0.5	1	1	8	0.94	6.4°	50	4	2	●	1	8.4	8.8	9.4	10.2
CRN2XLB0050N080S06	0.5	1	1	8	0.94	8.3°	50	6	2	●	1	8.4	8.8	9.4	10.2
CRN2XLB0050N100S04	0.5	1	1	10	0.94	5.6°	50	4	2	●	1	10.5	10.9	11.7	12.6
CRN2XLB0050N120S04	0.5	1	1	12	0.94	5°	50	4	2	●	1	12.6	13.1	14	15.1

● : Inventory maintained.

(mm)

Order Number	RE	DC	APMX	LU	DN	B2	LF	DCON	Flutes	Stock	Type	Effective length for inclined angle			
												0.5°	1°	2°	3°
CRN2XLBR0050N160S04	0.5	1	1	16	0.94	4.1°	55	4	2	●	1	16.8	17.4	18.6	20.1
CRN2XLBR0050N200S04	0.5	1	1	20	0.94	3.4°	55	4	2	●	1	20.9	21.6	23.2	25.1
CRN2XLBR0075N080S04	0.75	1.5	1.5	8	1.44	5.9°	50	4	2	●	1	8.4	8.8	9.4	10.1
CRN2XLBR0075N080S06	0.75	1.5	1.5	8	1.44	8.1°	50	6	2	●	1	8.4	8.8	9.4	10.1
CRN2XLBR0075N100S04	0.75	1.5	1.5	10	1.44	5.1°	50	4	2	●	1	10.5	10.9	11.7	12.6
CRN2XLBR0075N100S06	0.75	1.5	1.5	10	1.44	7.2°	50	6	2	●	1	10.5	10.9	11.7	12.6
CRN2XLBR0075N160S04	0.75	1.5	1.5	16	1.44	3.6°	55	4	2	●	1	16.8	17.3	18.6	20
CRN2XLBR0100N080S04	1	2	2	8	1.90	5.3°	50	4	2	●	1	8.3	8.7	9.2	9.9
CRN2XLBR0100N100S04	1	2	2	10	1.90	4.5°	50	4	2	●	1	10.4	10.8	11.5	12.4
CRN2XLBR0100N100S06	1	2	2	10	1.90	6.9°	50	6	2	●	1	10.4	10.8	11.5	12.4
CRN2XLBR0100N120S04	1	2	2	12	1.90	3.9°	50	4	2	●	1	12.5	12.9	13.8	14.9
CRN2XLBR0100N120S06	1	2	2	12	1.90	6.1°	50	6	2	●	1	12.5	12.9	13.8	14.9
CRN2XLBR0100N140S06	1	2	2	14	1.90	5.6°	55	6	2	●	1	14.6	15.1	16.1	17.4
CRN2XLBR0100N160S04	1	2	2	16	1.90	3.1°	55	4	2	●	1	16.7	17.2	18.4	19.9
CRN2XLBR0100N200S04	1	2	2	20	1.90	2.5°	60	4	2	●	1	20.8	21.5	23	*
CRN2XLBR0100N250S06	1	2	2	25	1.90	3.7°	65	6	2	●	1	26	26.8	28.8	31
CRN2XLBR0100N300S06	1	2	2	30	1.90	3.2°	70	6	2	●	1	31.1	32.2	34.5	37.3
CRN2XLBR0150N160S06	1.5	3	3	16	2.90	4.3°	60	6	2	●	1	16.6	17.2	18.4	19.7
CRN2XLBR0150N250S06	1.5	3	3	25	2.90	3°	70	6	2	●	1	26	26.8	28.7	*
CRN2XLBR0150N350S06	1.5	3	3	35	2.90	2.2°	80	6	2	●	1	36.3	37.5	40.2	*
CRN2XLBR0200N160S06	2	4	4	16	3.90	3.2°	70	6	2	●	1	16.6	17.1	18.3	19.6
CRN2XLBR0200N200S06	2	4	4	20	3.90	2.7°	70	6	2	●	1	20.8	21.4	22.9	*
CRN2XLBR0200N300S06	2	4	4	30	3.90	1.8°	70	6	2	●	1	31.1	32.1	*	*
CRN2XLBR0200N400S06	2	4	4	40	3.90	1.4°	90	6	2	●	1	41.4	42.8	*	*
CRN2XLBR0250N200S06	2.5	5	5	20	4.90	1.5°	70	6	2	●	1	20.7	21.4	*	*
CRN2XLBR0300N300S06	3	6	6	30	5.85	—	80	6	2	●	2	*	*	*	*
CRN2XLBR0300N500S06	3	6	6	50	5.85	—	100	6	2	●	2	*	*	*	*

* No interference

SOLID END MILLS

SQUARE

BALL

RADIUS

TAPER

BARREL

ROUGHING

CRN COATED END MILLS

CRN2XLB

Ball nose, Long neck, For copper electrodes, 2 flute

CARBIDE

SOLID END MILLS

SQUARE

BALL

RADIUS

TAPER

BARREL

ROUGHING

RECOMMENDED CUTTING CONDITIONS

Work material		N		
		Copper, Copper alloys		
RE (mm)	Neck length LU (mm)	Revolution (min ⁻¹)	Feed rate (mm/min)	Depth of cut ap (mm)
R0.1	0.5	40000	800	0.003
	1.0	40000	600	0.002
	1.5	40000	400	0.001
R0.15	1	40000	1200	0.007
	2	40000	800	0.003
R0.2	1	40000	2000	0.015
	2	40000	1300	0.01
	3	40000	800	0.005
R0.25	2	40000	2000	0.02
	4	40000	1200	0.01
	6	36000	600	0.006
	10	26000	200	0.002
R0.3	2	40000	3200	0.03
	6	40000	1200	0.008
	10	30000	500	0.003
R0.4	4	40000	4000	0.02
	6	40000	2500	0.02
	10	30000	700	0.008
R0.5	4	40000	6400	0.05
	6	40000	4800	0.03
	8	40000	3000	0.02
	10	33000	2000	0.01
	16	18000	500	0.008
	20	13000	250	0.005

Work material		N		
		Copper, Copper alloys		
RE (mm)	Neck length LU (mm)	Revolution (min ⁻¹)	Feed rate (mm/min)	Depth of cut ap (mm)
R0.75	8	40000	8000	0.07
	12	35000	4500	0.04
	16	20000	2000	0.03
	20	12000	900	0.02
R1	8	40000	9600	0.10
	10	40000	6400	0.08
	12	40000	6000	0.08
	16	30000	3000	0.05
	20	20000	2000	0.04
R1.5	30	10000	800	0.02
	16	40000	12000	0.10
	25	25000	6000	0.08
R2	35	6000	700	0.06
	16	32000	11000	0.15
	20	32000	9000	0.15
	30	20000	4500	0.10
R2.5	40	15000	3000	0.08
	50	8000	1000	0.05
	20	25000	9500	0.20
R3	30	20000	3300	0.15
	30	21000	8400	0.20
	50	20000	3000	0.15

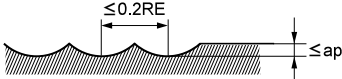
Depth of cut	
--------------	--

RE: Radius

Note 1) If the depth of cut is shallow, the revolution and feed rate can be increased.

Note 2) Water-soluble cutting fluid is recommended.

Note 3) Cutting conditions may be considerably different due to the overhang (milling depth), depth of cut, and machine tool. Please see the above table as a standard.

CRN2MS

End mill, Medium cut length, For copper electrodes, 2 flute



CARBIDE

Carbon Steel, Alloy Steel, Cast Iron (<30HRC)	Tool Steel, Pre-Hardened Steel, Hardened Steel (≤45HRC)	Hardened Steel (≤55HRC)	Hardened Steel (>55HRC)	Austenitic Stainless Steel	Titanium Alloy, Heat Resistant Alloy	Copper Alloy	Aluminium Alloy
						○	○

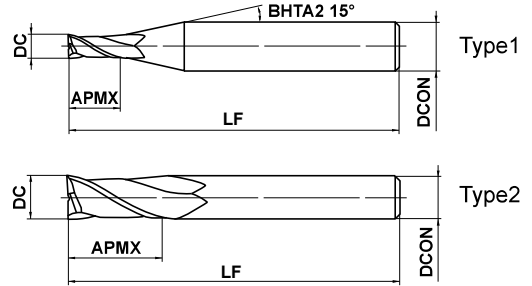

	0.2 ≤ DC ≤ 12				
	$\begin{matrix} 0 \\ -0.02 \end{matrix}$				
	4 ≤ DCON ≤ 6	8 ≤ DCON ≤ 10	DCON = 12		
	$\begin{matrix} 0 \\ -0.008 \end{matrix}$	$\begin{matrix} 0 \\ -0.009 \end{matrix}$	$\begin{matrix} 0 \\ -0.011 \end{matrix}$		

● 2 flute end mill with CRN coating for copper electrode machining.

(mm)

Order Number	DC	APMX	LF	DCON	Flutes	Stock	Type
CRN2MSD0020S04	0.2	0.4	40	4	2	●	1
CRN2MSD0030S04	0.3	0.6	40	4	2	●	1
CRN2MSD0040S04	0.4	0.8	40	4	2	●	1
CRN2MSD0050S04	0.5	1	40	4	2	●	1
CRN2MSD0060S04	0.6	1.2	40	4	2	●	1
CRN2MSD0070S04	0.7	1.4	40	4	2	●	1
CRN2MSD0080S04	0.8	1.6	40	4	2	●	1
CRN2MSD0100S04	1	2.5	40	4	2	●	1
CRN2MSD0100S06	1	2.5	45	6	2	●	1
CRN2MSD0150S04	1.5	4	40	4	2	●	1
CRN2MSD0150S06	1.5	4	45	6	2	●	1
CRN2MSD0170S04	1.7	4	40	4	2	●	1
CRN2MSD0200S06	2	6	45	6	2	●	1
CRN2MSD0250S06	2.5	8	45	6	2	●	1
CRN2MSD0300S06	3	8	45	6	2	●	1
CRN2MSD0400S06	4	11	45	6	2	●	1
CRN2MSD0500S06	5	13	50	6	2	●	1
CRN2MSD0600S06	6	13	50	6	2	●	2
CRN2MSD0800S08	8	19	60	8	2	●	2
CRN2MSD1000S10	10	22	70	10	2	●	2
CRN2MSD1200S12	12	26	75	12	2	●	2

SOLID END MILLS

SQUARE

BALL

RADIUS

TAPER

BARREL

ROUGHING

● : Inventory maintained.

CRN COATED END MILLS

CRN2MS

End mill, Medium cut length, For copper electrodes, 2 flute

CARBIDE

—

SOLID END MILLS

SQUARE

BALL

RADIUS

TAPER

BARREL

ROUGHING

RECOMMENDED CUTTING CONDITIONS

Dia. DC (mm)	N		
	Revolution (min ⁻¹)	Feed rate (mm/min)	Depth of cut (mm)
Work material Copper, Copper alloys			
0.2	40000	600	0.01
0.3	40000	600	0.01
0.4	40000	800	0.01
0.5	40000	960	0.015
0.6	40000	1200	0.02
0.7	40000	1400	0.02
0.8	40000	1600	0.03
0.9	40000	1800	0.04
1	40000	2000	0.06
1.5	40000	3000	0.12
2	30000	3000	0.18
2.5	24000	2600	0.25
3	20000	2300	0.30
4	15000	2000	0.40
5	12000	1600	0.50
6	10000	1400	0.60
8	8000	1000	0.80
10	6400	900	1.00
12	5400	820	1.00

Depth of cut

Note 1) If the depth of cut is shallow, the revolution and feed rate can be increased.

Note 2) Water-soluble cutting fluid is recommended.

Note 3) When drilling, please set the feed rate at 1/3 or below of the table value.

Note 4) If the rigidity of the machine or the work materials installation is very low, or chattering and noise are generated, reduce the revolution and feed rate proportionately.

CRN4JC

End mill, Semi long cut length, For copper electrodes, 4 flute



CARBIDE

Carbon Steel, Alloy Steel, Cast Iron (<30HRC)	Tool Steel, Pre-Hardened Steel, Hardened Steel (≤45HRC)	Hardened Steel (≤55HRC)	Hardened Steel (>55HRC)	Austenitic Stainless Steel	Titanium Alloy, Heat Resistant Alloy	Copper Alloy	Aluminium Alloy
						○	○

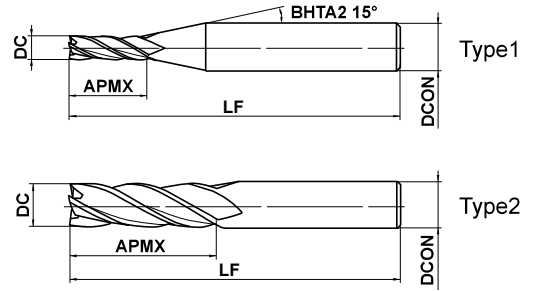

	3 ≤ DC ≤ 12				
	⁰ / _{-0.02}				
	DCON=6	8 ≤ DCON ≤ 10	DCON=12		
	⁰ / _{-0.008}	⁰ / _{-0.009}	⁰ / _{-0.011}		

● 4 flute end mill with CRN coating for copper electrode machining.

(mm)

Order Number	DC	APMX	LF	DCON	Flutes	Stock	Type
CRN4JCD0300	3	12	50	6	4	●	1
CRN4JCD0400	4	15	50	6	4	●	1
CRN4JCD0600	6	20	60	6	4	●	2
CRN4JCD0800	8	25	70	8	4	●	2
CRN4JCD1000	10	30	90	10	4	●	2
CRN4JCD1200	12	30	90	12	4	●	2

RECOMMENDED CUTTING CONDITIONS

N		
Work material	Copper, Copper alloys	
Dia. DC (mm)	Revolution (min ⁻¹)	Feed rate (mm/min)
3	10600	280
4	8000	330
5	6400	380
6	5300	420
8	4000	460
10	3200	460
12	2700	460

Depth of cut		≤ 0.05DC (MAX. 0.5mm)
		≤ 2.5DC

DC: Dia.

Note 1) If the depth of cut is shallow, the revolution and feed rate can be increased.

Note 2) Water-soluble cutting fluid is recommended.

Note 3) When drilling, please reduce the feed rate by 65%.

Note 4) If the rigidity of the machine or the work materials installation is very low, or chattering and noise are generated, reduce the revolution and feed rate proportionately.

● : Inventory maintained.

SOLID END MILLS

SQUARE

BALL

RADIUS

TAPER

BARREL

ROUGHING

CRN COATED END MILLS

CRN2XL

End mill, Long neck, For copper electrodes, 2 flute



DC < 3 DC ≥ 3

Carbon Steel, Alloy Steel, Cast Iron (<30HRC)	Tool Steel, Pre-Hardened Steel, Hardened Steel (≤45HRC)	Hardened Steel (≤55HRC)	Hardened Steel (>55HRC)	Austenitic Stainless Steel	Titanium Alloy, Heat Resistant Alloy	Copper Alloy	Aluminium Alloy
						○	○

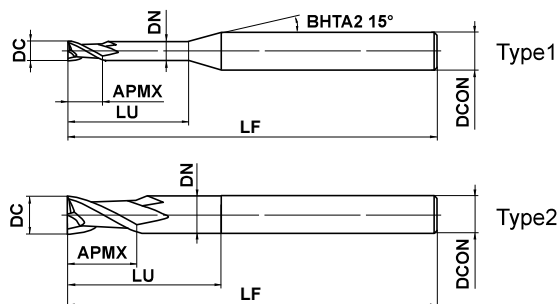

SOLID END MILLS



0.3 ≤ DC ≤ 6				
0				
- 0.02				
4 ≤ DCON ≤ 6				
0				
- 0.008				



● 2 flute long neck end mill with CRN coating for copper electrode machining.

(mm)

Order Number	DC	APMX	LU	DN	LF	DCON	Flutes	Stock	Type
CRN2XLD0030N010S04	0.3	0.5	1	0.27	50	4	2	●	1
CRN2XLD0030N030S04	0.3	0.5	3	0.27	50	4	2	●	1
CRN2XLD0040N020S04	0.4	0.6	2	0.36	50	4	2	●	1
CRN2XLD0050N020S04	0.5	0.8	2	0.46	50	4	2	●	1
CRN2XLD0050N040S04	0.5	0.8	4	0.46	50	4	2	●	1
CRN2XLD0050N060S04	0.5	0.8	6	0.46	50	4	2	●	1
CRN2XLD0080N040S04	0.8	1.2	4	0.76	50	4	2	●	1
CRN2XLD0100N060S04	1	1.5	6	0.94	50	4	2	●	1
CRN2XLD0100N060S06	1	1.5	6	0.94	50	6	2	●	1
CRN2XLD0100N080S04	1	1.5	8	0.94	50	4	2	●	1
CRN2XLD0100N100S04	1	1.5	10	0.94	50	4	2	●	1
CRN2XLD0100N120S04	1	1.5	12	0.94	50	4	2	●	1
CRN2XLD0150N060S04	1.5	2.3	6	1.44	50	4	2	●	1
CRN2XLD0150N080S04	1.5	2.3	8	1.44	50	4	2	●	1
CRN2XLD0150N100S04	1.5	2.3	10	1.44	50	4	2	●	1
CRN2XLD0150N120S04	1.5	2.3	12	1.44	50	4	2	●	1
CRN2XLD0200N060S06	2	3.0	6	1.90	50	6	2	●	1
CRN2XLD0200N080S06	2	3.0	8	1.90	50	6	2	●	1
CRN2XLD0200N100S06	2	3.0	10	1.90	50	6	2	●	1
CRN2XLD0200N120S06	2	3.0	12	1.90	50	6	2	●	1
CRN2XLD0200N200S06	2	3.0	20	1.90	60	6	2	●	1
CRN2XLD0250N200S06	2.5	3.8	20	2.40	65	6	2	●	1
CRN2XLD0300N200S06	3	4.5	20	2.90	65	6	2	●	1
CRN2XLD0400N200S06	4	6.0	20	3.90	65	6	2	●	1
CRN2XLD0500N250S06	5	7.5	25	4.90	70	6	2	●	1
CRN2XLD0600N300S06	6	9.0	30	5.85	70	6	2	●	2

● : Inventory maintained.

RECOMMENDED CUTTING CONDITIONS

Work material		N		
		Copper, Copper alloys		
Dia. DC (mm)	Neck length LU (mm)	Revolution (min ⁻¹)	Feed rate (mm/min)	Depth of cut per pass (mm)
0.2	0.5	40000	800	0.004
	1.0	40000	700	0.003
	1.5	40000	600	0.002
0.3	1	40000	800	0.007
	3	40000	600	0.002
0.4	2	40000	950	0.007
	4	40000	800	0.003
	6	40000	600	0.001
0.5	2	40000	950	0.01
	4	40000	800	0.005
	6	40000	700	0.002
0.8	4	40000	1200	0.02
	6	40000	1200	0.015
	8	40000	1000	0.01
1	6	40000	2000	0.04
	8	40000	2000	0.03
	10	30000	1200	0.02
	12	30000	1000	0.015
1.5	6	40000	2400	0.10
	8	40000	2200	0.09
	10	40000	2000	0.08
	12	30000	1800	0.05
	16	20000	1200	0.03
	20	15000	800	0.02
2	6	40000	2400	0.18
	8	40000	2200	0.15
	10	40000	2000	0.12
	12	30000	1500	0.10
	16	30000	1000	0.06
	20	15000	600	0.03
2.5	8	40000	3000	0.20
	12	40000	2800	0.15
	16	30000	2100	0.10
	20	20000	1000	0.08
3	20	20000	2000	0.12
4	20	15000	2000	0.30
5	25	12000	1500	0.35
6	30	10000	1200	0.40

Note 1) If the depth of cut is shallow, the revolution and feed rate can be increased.

Note 2) Water-soluble cutting fluid is recommended.

Note 3) Cutting condition may be considerably different due to the overhang (milling depth), depth of cut, and machine tools. Please see the above table as a standard.

CRN COATED END MILLS

CRN2MRB

Corner radius end mill, Medium cut length, For copper electrodes, 2 flute



Carbon Steel, Alloy Steel, Cast Iron (<30HRC)	Tool Steel, Pre-Hardened Steel, Hardened Steel (≤45HRC)	Hardened Steel (≤55HRC)	Hardened Steel (>55HRC)	Austenitic Stainless Steel	Titanium Alloy, Heat Resistant Alloy	Copper Alloy	Aluminium Alloy
						○	○

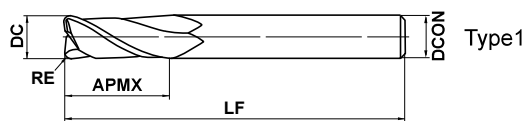

SOLID END MILLS

	6 ≤ DC ≤ 12				
	⁰ / _{-0.02}				
	DCON=6	8 ≤ DCON ≤ 10	DCON=12		
	⁰ / _{-0.008}	⁰ / _{-0.009}	⁰ / _{-0.011}		

● 2 flute corner radius end mill with CRN coating for copper electrode machining.

(mm)

Order Number	DC	RE	APMX	LF	DCON	Flutes	Stock	Type
CRN2MRBD0600R020	6	0.2	13	50	6	2	●	1
CRN2MRBD0600R050	6	0.5	13	50	6	2	●	1
CRN2MRBD0800R050	8	0.5	19	60	8	2	●	1
CRN2MRBD0800R100	8	1	19	60	8	2	●	1
CRN2MRBD1000R050	10	0.5	22	70	10	2	●	1
CRN2MRBD1000R100	10	1	22	70	10	2	●	1
CRN2MRBD1200R050	12	0.5	26	75	12	2	●	1
CRN2MRBD1200R100	12	1	26	75	12	2	●	1

SQUARE

BALL

RADIUS

TAPER

BARREL

ROUGHING

● : Inventory maintained.

RECOMMENDED CUTTING CONDITIONS

Work material		N			
		Copper, Copper alloys			
Dia. DC (mm)	Corner radius RE (mm)	Revolution (min ⁻¹)	Feed rate (mm/min)	Depth of cut	
				ap (mm)	ae (mm)
6	R0.2, R0.3, R0.5	10000	1400	6	0.6
	R1	10000	1700	6	0.6
8	R0.3, R0.5	8000	1000	8	0.8
	R1	8000	1200	8	0.8
10	R0.3, R0.5	6400	900	10	1.0
	R1	6400	1100	10	1.0
12	R0.3, R0.5	5400	800	12	1.0
	R1	5400	1000	12	1.0
Depth of cut		<p style="text-align: right;">DC: Dia.</p>			

Note 1) If the depth of cut is shallow, the revolution and feed rate can be increased.

Note 2) Water-soluble cutting fluid is recommended.

Note 3) If the rigidity of the machine or the work materials installation is very low, or chattering and noise are generated, reduce the revolution and feed rate proportionately.

CRN COATED END MILLS

CRN2XLRB

Corner radius end mill, Short cut length, For copper electrodes, 2 flute



Carbon Steel, Alloy Steel, Cast Iron (<30HRC)	Tool Steel, Pre-Hardened Steel, Hardened Steel (≤45HRC)	Hardened Steel (≤55HRC)	Hardened Steel (>55HRC)	Austenitic Stainless Steel	Titanium Alloy, Heat Resistant Alloy	Copper Alloy	Aluminium Alloy
						☉	○



Effective length for inclined angle

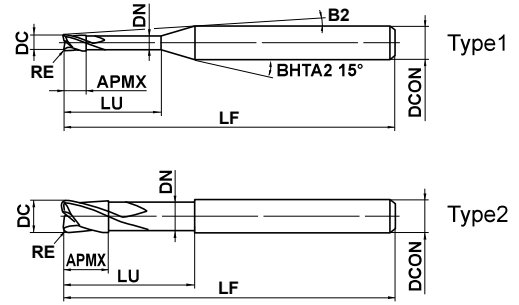
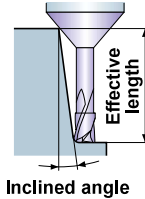

	0.5 ≤ DC ≤ 6		
	0 - 0.02		
	4 ≤ DCON ≤ 6		
	0 - 0.008		

● 2 flute long neck corner radius end mill with CRN coating for copper electrode machining.

(mm)

Order Number	DC	RE	APMX	LU	DN	B2	LF	DCON	Flutes	Stock	Type	Effective length for inclined angle			
												30°	1°	2°	3°
CRN2XLRBD0050R005N04	0.5	0.05	0.5	4	0.46	9.5°	50	4	2	●	1	4.1	4.3	4.6	5
CRN2XLRBD0050R010N04	0.5	0.1	0.5	4	0.46	9.5°	50	4	2	●	1	4.1	4.3	4.6	5
CRN2XLRBD0100R010N08	1	0.1	1	8	0.94	6.3°	50	4	2	●	1	8.5	8.8	9.5	10.2
CRN2XLRBD0100R030N08	1	0.3	1	8	0.94	6.3°	50	4	2	●	1	8.5	8.8	9.5	10.2
CRN2XLRBD0100R030N12	1	0.3	1	12	0.94	4.9°	55	4	2	●	1	12.6	13.1	14.1	15.2
CRN2XLRBD0150R020N12	1.5	0.2	1.5	12	1.44	4.3°	55	4	2	●	1	12.6	13.1	14.1	15.2
CRN2XLRBD0150R030N12	1.5	0.3	1.5	12	1.44	4.3°	55	4	2	●	1	12.6	13.1	14.1	15.2
CRN2XLRBD0200R010N12	2	0.1	2	12	1.9	3.7°	55	4	2	●	1	12.5	13	14	15.1
CRN2XLRBD0200R020N12	2	0.2	2	12	1.9	3.7°	55	4	2	●	1	12.5	13	14	15.1
CRN2XLRBD0200R030N12	2	0.3	2	12	1.9	3.7°	55	4	2	●	1	12.5	13	13.9	15
CRN2XLRBD0200R050N12	2	0.5	2	12	1.9	3.8°	55	4	2	●	1	12.5	13	13.9	15
CRN2XLRBD0200R020N16	2	0.2	2	16	1.9	2.9°	55	4	2	●	1	16.7	17.3	18.6	*
CRN2XLRBD0200R030N16	2	0.3	2	16	1.9	3°	55	4	2	●	1	16.7	17.3	18.5	*
CRN2XLRBD0200R020N20	2	0.2	2	20	1.9	2.5°	60	4	2	●	1	20.8	21.5	23.2	*
CRN2XLRBD0300R020N20	3	0.2	3	20	2.9	3.4°	65	6	2	●	1	20.8	21.5	23.2	25
CRN2XLRBD0300R030N20	3	0.3	3	20	2.9	3.4°	65	6	2	●	1	20.8	21.5	23.1	25
CRN2XLRBD0300R050N20	3	0.5	3	20	2.9	3.4°	65	6	2	●	1	20.8	21.5	23.1	24.9
CRN2XLRBD0400R020N20	4	0.2	4	20	3.9	2.5°	65	6	2	●	1	20.8	21.5	23.2	*
CRN2XLRBD0400R030N20	4	0.3	4	20	3.9	2.5°	65	6	2	●	1	20.8	21.5	23.1	*
CRN2XLRBD0400R050N20	4	0.5	4	20	3.9	2.5°	65	6	2	●	1	20.8	21.5	23.1	*
CRN2XLRBD0600R020N30	6	0.2	6	30	5.85	—	70	6	2	●	2	*	*	*	*
CRN2XLRBD0600R030N30	6	0.3	6	30	5.85	—	70	6	2	●	2	*	*	*	*
CRN2XLRBD0600R050N30	6	0.5	6	30	5.85	—	70	6	2	●	2	*	*	*	*
CRN2XLRBD0600R100N30	6	1	6	30	5.85	—	70	6	2	●	2	*	*	*	*

* No interference

● : Inventory maintained.

RECOMMENDED CUTTING CONDITIONS

■ Slotting

■ Contour Cutting

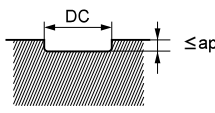
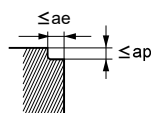
Work material			N						
			Copper, Copper alloys			Copper, Copper alloys			
Dia. DC (mm)	Corner radius RE (mm)	Neck length (mm)	Revolution (min ⁻¹)	Feed rate (mm/min)	Depth of cut ap (mm)	Revolution (min ⁻¹)	Feed rate (mm/min)	Depth of cut	
								ap (mm)	ae (mm)
0.5	R0.05, R0.1	4	40000	800	0.005	40000	1500	0.01	0.1
		6	40000	700	0.003	40000	1000	0.005	0.1
0.8	R0.05, R0.1	6	40000	1200	0.02	40000	2500	0.02	0.15
		8	40000	1200	0.015	40000	1600	0.01	0.15
1	R0.1, R0.3	8	40000	2000	0.03	40000	3000	0.03	0.2
		10	35000	1600	0.025	35000	2000	0.025	0.2
		12	30000	1200	0.02	30000	1800	0.02	0.2
1.5	R0.1, R0.2, R0.3	12	30000	1500	0.05	40000	4500	0.04	0.3
		20	20000	1000	0.02	20000	2000	0.02	0.3
2	R0.1, R0.2 R0.3, R0.5	12	30000	1500	0.1	40000	4500	0.08	0.4
		16	30000	1000	0.06	30000	3000	0.05	0.4
		20	20000	600	0.04	20000	2000	0.04	0.4
3	R0.2, R0.3	20	20000	2000	0.12	35000	6000	0.1	0.6
	R0.5	20	20000	2200	0.12	35000	8000	0.1	0.6
4	R0.2, R0.3	20	15000	2000	0.25	32000	5000	0.15	0.8
	R0.5	20	15000	2200	0.25	32000	7000	0.15	0.8
5	R0.2, R0.3	25	12000	1500	0.3	22000	5000	0.2	1.0
	R0.5	25	12000	1700	0.3	22000	7000	0.2	1.0
6	R0.2, R0.3, R0.5	30	10000	1200	0.4	20000	5000	0.25	1.2
	R1	30	10000	1500	0.4	20000	7000	0.25	1.2
Depth of cut									

Note 1) If the depth of cut is shallow, the revolution and feed rate can be increased.

Note 2) Water-soluble cutting fluid is recommended.

Note 3) Cutting conditions may be considerably different due to the overhang (milling depth), depth of cut, and machine tool. Please see the above table as a standard.

ALIMASTER END MILLS

AM2MB

Ball nose end mill, Medium cut length, Relieved neck, 2 flute



Carbon Steel, Alloy Steel, Cast Iron (<30HRC)	Tool Steel, Pre-Hardened Steel, Hardened Steel (<=45HRC)	Hardened Steel (<=55HRC)	Hardened Steel (>55HRC)	Austenitic Stainless Steel	Titanium Alloy, Heat Resistant Alloy	Copper Alloy	Aluminium Alloy
---	--	--------------------------	-------------------------	----------------------------	--------------------------------------	--------------	-----------------

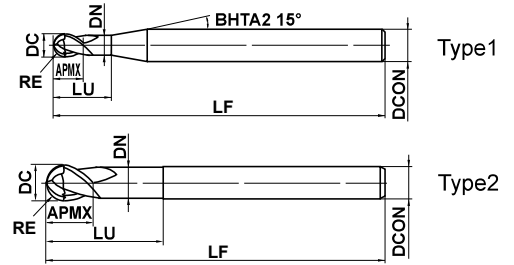

SOLID END MILLS

	RE ≤ 6	RE > 6			
	±0.01	±0.02			
	DC ≤ 3	3 < DC < 6	6 ≤ DC		
	0 - 0.020	0 - 0.028	0 - 0.038		

- High accuracy long reach ball nose cutter for aluminium.
- For machining to extreme tolerances with a superior surface finish.

(mm)

Order Number	RE	DC	APMX	LU	DN	LF	DCON	Flutes	Stock	Type
AM2MBR0050A040	0.5	1	2.5	—	—	40	4	2	●	1
AM2MBR0100A060	1	2	6	—	—	60	6	2	●	1
AM2MBR0150A060	1.5	3	6	9	2.7	60	6	2	●	1
AM2MBR0200A060	2	4	6	12	3.7	60	6	2	●	1
AM2MBR0250A060	2.5	5	8	15	4.7	60	6	2	●	1
AM2MBR0300A060	3	6	10	18	5.7	60	6	2	●	2
AM2MBR0400A075	4	8	12	24	7.4	75	8	2	●	2
AM2MBR0500A075	5	10	15	30	9.4	75	10	2	●	2
AM2MBR0600A075	6	12	18	36	11.4	75	12	2	●	2
AM2MBR0800A100	8	16	24	40	15.4	100	16	2	●	2
AM2MBR1000A100	10	20	30	45	19.0	100	20	2	●	2

RECOMMENDED CUTTING CONDITIONS

Work material	Finishing		Roughing	
	N		N	
Aluminium alloy	Aluminium alloy			
RE (mm)	Revolution (min ⁻¹)	Feed rate (mm/min)	Revolution (min ⁻¹)	Feed rate (mm/min)
R 1	20000	2000	20000	1600
R 2	20000	4000	20000	2800
R 3	20000	6000	20000	3200
R 4	20000	7000	17000	4000
R 5	20000	8000	15000	3600
R 6	15000	7500	12000	3600
R 8	12000	7200	10000	3600
R 10	10000	7000	8000	3200

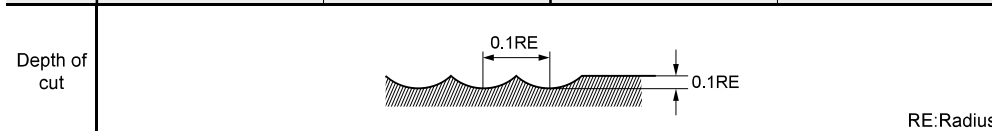

* When sinking, reduce the feed rate by 50%.

● : Inventory maintained.

AM2SC

End mill, Short cut length, Relieved neck, Centre cutting, 2 flute



CARBIDE

Carbon Steel, Alloy Steel, Cast Iron (<30HRC)	Tool Steel, Pre-Hardened Steel, Hardened Steel (≤45HRC)	Hardened Steel (≤55HRC)	Hardened Steel (>55HRC)	Austenitic Stainless Steel	Titanium Alloy, Heat Resistant Alloy	Copper Alloy	Aluminium Alloy
---	---	-------------------------	-------------------------	----------------------------	--------------------------------------	--------------	-----------------

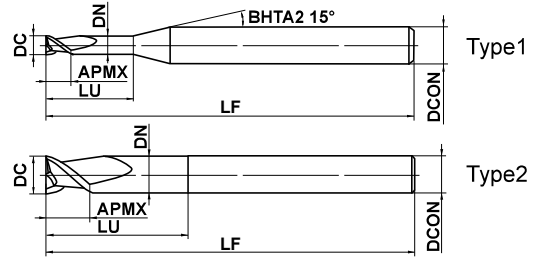

DC=3	3<DC≤6	6<DC≤16	16<DC
- 0.005 - 0.028	- 0.015 - 0.038	- 0.02 - 0.047	- 0.02 - 0.053

● Optimum choice for high speed machining of aluminium.

Order Number	DC	APMX	LU	DN	LF	DCON	Flutes	Stock	Type
AM2SCD0300A060	3	6	12	2.7	60	6	2	●	1
AM2SCD0400A060	4	6	12	3.7	60	6	2	●	1
AM2SCD0500A060	5	8	15	4.7	60	6	2	●	1
AM2SCD0600A075	6	8	16	5.7	75	6	2	●	2
AM2SCD0800A075	8	10	20	7.4	75	8	2	●	2
AM2SCD1000A075	10	12	30	9.4	75	10	2	●	2
AM2SCD1000A100	10	12	35	9.4	100	10	2	●	2
AM2SCD1200A075	12	15	30	11.4	75	12	2	●	2
AM2SCD1200A100	12	15	35	11.4	100	12	2	●	2
AM2SCD1200A125	12	15	40	11.4	125	12	2	●	2
AM2SCD1600A075	16	15	30	15.4	75	16	2	●	2
AM2SCD1600A100	16	15	40	15.4	100	16	2	●	2
AM2SCD1600A125	16	15	45	15.4	125	16	2	●	2
AM2SCD2000A100	20	20	40	18.0	100	20	2	●	2
AM2SCD2000A125	20	20	50	18.0	125	20	2	●	2

RECOMMENDED CUTTING CONDITIONS

Work material	N	
	Aluminium alloy	
Dia. DC (mm)	Revolution (min ⁻¹)	Feed rate (mm/min)
3	20000	800—1600
6	20000	1800—2800
8	17000	2200—3400
10	15000	2300—3600
12	12000	2300—3600
16	10000	2300—3600
20	8000	2200—3300

Depth of cut	0.25—0.5DC	1DC
	DC	0.25—0.5DC

DC: Dia.

SOLID END MILLS

SQUARE

BALL

RADIUS

TAPER

BARREL

ROUGHING

ALIMASTER END MILLS

AM2MR

End mill, Medium cut length, General purpose cutter, 2 flute



Carbon Steel, Alloy Steel, Cast Iron (<30HRC)	Tool Steel, Pre-Hardened Steel, Hardened Steel (≤45HRC)	Hardened Steel (≤55HRC)	Hardened Steel (>55HRC)	Austenitic Stainless Steel	Titanium Alloy, Heat Resistant Alloy	Copper Alloy	Aluminium Alloy
						○	◎

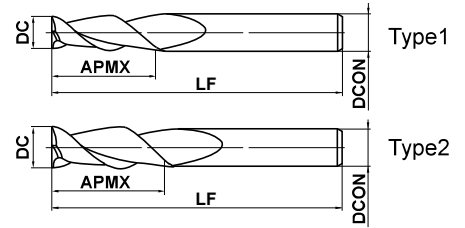

DC=3	3<DC≤6	6<DC≤10	10<DC≤16	16<DC
0 - 0.006	0 - 0.008	0 - 0.009	0 - 0.011	0 - 0.013

- Optimum choice for high speed rough and finish machining of aluminium.
- For ultra high metal removal rates.

(mm)

Order Number	DC	APMX	LF	DCON	Flutes	Stock	Type
AM2MRD0300A060	3	9	60	3	2	●	2
AM2MRD0300A060S06	3	9	60	6	2	●	1
AM2MRD0400A060	4	12	60	4	2	●	2
AM2MRD0400A060S06	4	12	60	6	2	●	1
AM2MRD0500A060	5	15	60	5	2	●	2
AM2MRD0500A060S06	5	15	60	6	2	●	1
AM2MRD0600A060	6	18	60	6	2	●	2
AM2MRD0800A075	8	20	75	8	2	●	2
AM2MRD1000A075	10	25	75	10	2	●	2
AM2MRD1200A075	12	25	75	12	2	●	2
AM2MRD1400A075	14	32	75	16	2	●	1
AM2MRD1600A100	16	32	100	16	2	●	2
AM2MRD2000A100	20	38	100	20	2	●	2
AM2MRD2500A125	25	38	125	25	2	●	2

RECOMMENDED CUTTING CONDITIONS

Work material	N	
	Aluminium alloy	
Dia. DC (mm)	Revolution (min ⁻¹)	Feed rate (mm/min)
3	20000	1200—1600
6	20000	2800—4000
8	17000	3000—4000
10	15000	3600—4500
12	12000	3600—4500
16	10000	3600—4500
20	8000	3200—4300
25	6000	3000—3600

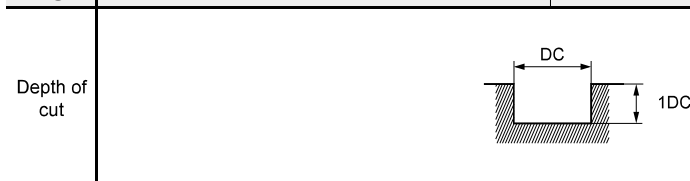

DC: Dia.

- : Inventory maintained.

AM3SS

End mill, Short cut length, Relieved neck, Non centre cutting, 3 flute

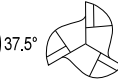

CARBIDE

Carbon Steel, Alloy Steel, Cast Iron (<30HRC)	Tool Steel, Pre-Hardened Steel, Hardened Steel (≤45HRC)	Hardened Steel (≤55HRC)	Hardened Steel (>55HRC)	Austenitic Stainless Steel	Titanium Alloy, Heat Resistant Alloy	Copper Alloy	Aluminium Alloy
---	---	-------------------------	-------------------------	----------------------------	--------------------------------------	--------------	-----------------

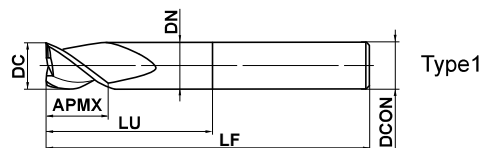

12 ≤ DC ≤ 16	16 < DC			
- 0.02	- 0.02			
- 0.047	- 0.053			

● Optimum choice for high speed machining of aluminium.

(mm)

Order Number	DC	APMX	LU	DN	LF	DCON	Flutes	Stock	Type
AM3SSD1000A075	10	12	30	9.4	75	10	3	●	1
AM3SSD1000A100	10	12	35	9.4	100	10	3	●	1
AM3SSD1200A075	12	15	30	11.4	75	12	3	●	1
AM3SSD1200A100	12	15	35	11.4	100	12	3	●	1
AM3SSD1200A125	12	15	40	11.4	125	12	3	●	1
AM3SSD1600A075	16	15	30	15.4	75	16	3	●	1
AM3SSD1600A100	16	15	40	15.4	100	16	3	●	1
AM3SSD1600A125	16	15	45	15.4	125	16	3	●	1
AM3SSD2000A100	20	20	40	18.0	100	20	3	●	1
AM3SSD2000A125	20	20	60	18.0	125	20	3	●	1
AM3SSD2000A150	20	20	85	18.0	150	20	3	●	1
AM3SSD2500A100	25	20	50	23.0	100	25	3	●	1
AM3SSD2500A125	25	20	65	23.0	125	25	3	●	1
AM3SSD2500A150	25	20	90	23.0	150	25	3	●	1

RECOMMENDED CUTTING CONDITIONS

Work material	N	
	Aluminium alloy	
Dia. DC (mm)	Revolution (min ⁻¹)	Feed rate (mm/min)
12	12000	1600—2500
16	10000	1300—2100
20	8000	1100—1600
25	6000	800—1200

Depth of cut		
	DC: Dia.	

SOLID END MILLS

SQUARE

BALL

RADIUS

TAPER

BARREL

ROUGHING

ALIMASTER END MILLS

AM3MF

End mill, Medium cut length, Centre cutting, 3 flute



Carbon Steel, Alloy Steel, Cast Iron (<30HRC)	Tool Steel, Pre-Hardened Steel, Hardened Steel (≤45HRC)	Hardened Steel (≤55HRC)	Hardened Steel (>55HRC)	Austenitic Stainless Steel	Titanium Alloy, Heat Resistant Alloy	Copper Alloy	Aluminium Alloy
---	---	-------------------------	-------------------------	----------------------------	--------------------------------------	--------------	-----------------

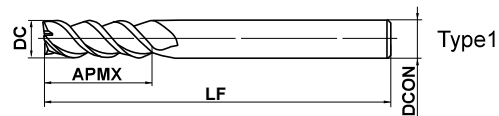

SOLID END MILLS



DC=6	6<DC≤16			
- 0.015	- 0.02			
- 0.038	- 0.047			

- Versatile end mill for slotting and side milling of aluminium.
- For high tolerance and precision finish machining.

(mm)

Order Number	DC	APMX	LF	DCON	Flutes	Stock	Type
AM3MFD0600A050	6	13	50	6	3	●	1
AM3MFD0800A060	8	19	60	8	3	●	1
AM3MFD1000A075	10	22	75	10	3	●	1
AM3MFD1200A075	12	26	75	12	3	●	1
AM3MFD1600A090	16	32	90	16	3	●	1

SQUARE

BALL

RADIUS

TAPER

BARREL

ROUGHING

RECOMMENDED CUTTING CONDITIONS

Work material	N	
	Aluminium alloy	
Dia. DC (mm)	Revolution (min ⁻¹)	Feed rate (mm/min)
6	20000	4200
8	17000	5100
10	15000	5400
12	12000	5400
16	10000	4800

Depth of cut	Diagram 1	Diagram 2
	0.05DC	DC
	1.5DC	0.1-0.3DC

DC: Dia.

● : Inventory maintained.

AM4MF

End mill, Medium cut length, Finishing type, Centre cutting, 4 flute



CARBIDE

Carbon Steel, Alloy Steel, Cast Iron (<30HRC)	Tool Steel, Pre-Hardened Steel, Hardened Steel (≤45HRC)	Hardened Steel (≤55HRC)	Hardened Steel (>55HRC)	Austenitic Stainless Steel	Titanium Alloy, Heat Resistant Alloy	Copper Alloy	Aluminium Alloy
---	---	-------------------------	-------------------------	----------------------------	--------------------------------------	--------------	-----------------

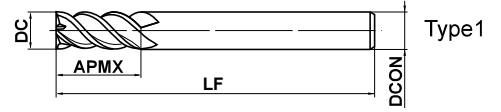

20 ≤ DC ≤ 25				
- 0.02				
- 0.053				

- Versatile 4 flute end mill for aluminium.
- For high tolerance and precision finish machining.

(mm)

Order Number	DC	APMX	LF	DCON	Flutes	Stock	Type
AM4MFD2000A100	20	38	100	20	4	●	1
AM4MFD2500A125	25	45	125	25	4	●	1

RECOMMENDED CUTTING CONDITIONS

Work material	N	
	Aluminium alloy	
Dia. DC (mm)	Revolution (min ⁻¹)	Feed rate (mm/min)
20	8000	5700
25	6000	4800

Depth of cut	DC: Dia.	
	0.05DC	1.5DC

SOLID END MILLS

SQUARE

BALL

RADIUS

TAPER

BARREL

ROUGHING

ALIMASTER END MILLS

AM2SCRB

Corner radius end mill, Short cut length, Relieved neck, 2 flute



Carbon Steel, Alloy Steel, Cast Iron (<30HRC)	Tool Steel, Pre-Hardened Steel, Hardened Steel (≤45HRC)	Hardened Steel (≤55HRC)	Hardened Steel (>55HRC)	Austenitic Stainless Steel	Titanium Alloy, Heat Resistant Alloy	Copper Alloy	Aluminium Alloy
---	---	-------------------------	-------------------------	----------------------------	--------------------------------------	--------------	-----------------

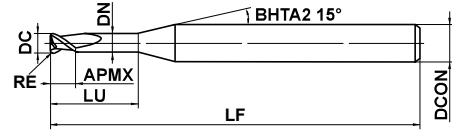

Type1

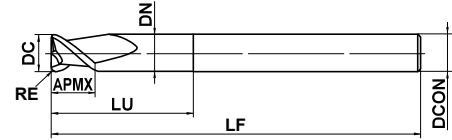

Type2



DC ≤ 12	DC > 12			
0	0			
- 0.020	- 0.030			

● High efficiency machining of aluminium alloy.

(mm)

Order Number	DC	RE	APMX	LU	DN	LF	DCON	Flutes	Stock	Type
AM2SCRBD0300A060R030	3	0.3	6	12	2.7	60	6	2	●	1
AM2SCRBD0300A060R050	3	0.5	6	12	2.7	60	6	2	●	1
AM2SCRBD0400A060R030	4	0.3	6	12	3.7	60	6	2	●	1
AM2SCRBD0400A060R050	4	0.5	6	12	3.7	60	6	2	●	1
AM2SCRBD0500A060R030	5	0.3	8	15	4.7	60	6	2	●	1
AM2SCRBD0500A060R050	5	0.5	8	15	4.7	60	6	2	●	1
AM2SCRBD0600A075R030	6	0.3	8	16	5.7	75	6	2	●	2
AM2SCRBD0600A075R050	6	0.5	8	16	5.7	75	6	2	●	2
AM2SCRBD0600A075R100	6	1	8	16	5.7	75	6	2	●	2
AM2SCRBD0800A075R030	8	0.3	10	20	7.4	75	8	2	●	2
AM2SCRBD0800A075R050	8	0.5	10	20	7.4	75	8	2	●	2
AM2SCRBD0800A075R100	8	1	10	20	7.4	75	8	2	●	2
AM2SCRBD0800A075R160	8	1.6	10	20	7.4	75	8	2	●	2
AM2SCRBD0800A075R250	8	2.5	10	20	7.4	75	8	2	●	2
AM2SCRBD1000A075R030	10	0.3	12	30	9.4	75	10	2	●	2
AM2SCRBD1000A075R050	10	0.5	12	30	9.4	75	10	2	●	2
AM2SCRBD1000A075R100	10	1	12	30	9.4	75	10	2	●	2
AM2SCRBD1000A075R160	10	1.6	12	30	9.4	75	10	2	●	2
AM2SCRBD1000A075R250	10	2.5	12	30	9.4	75	10	2	●	2
AM2SCRBD1000A100R030	10	0.3	12	35	9.4	100	10	2	●	2
AM2SCRBD1000A100R050	10	0.5	12	35	9.4	100	10	2	●	2
AM2SCRBD1000A100R100	10	1	12	35	9.4	100	10	2	●	2
AM2SCRBD1000A100R160	10	1.6	12	35	9.4	100	10	2	●	2
AM2SCRBD1000A100R250	10	2.5	12	35	9.4	100	10	2	●	2
AM2SCRBD1200A075R030	12	0.3	15	30	11.4	75	12	2	●	2
AM2SCRBD1200A075R050	12	0.5	15	30	11.4	75	12	2	●	2
AM2SCRBD1200A075R100	12	1	15	30	11.4	75	12	2	●	2
AM2SCRBD1200A075R160	12	1.6	15	30	11.4	75	12	2	●	2
AM2SCRBD1200A075R250	12	2.5	15	30	11.4	75	12	2	●	2
AM2SCRBD1200A075R320	12	3.2	15	30	11.4	75	12	2	●	2
AM2SCRBD1200A075R400	12	4	15	30	11.4	75	12	2	●	2
AM2SCRBD1200A100R030	12	0.3	15	35	11.4	100	12	2	●	2
AM2SCRBD1200A100R050	12	0.5	15	35	11.4	100	12	2	●	2
AM2SCRBD1200A100R100	12	1	15	35	11.4	100	12	2	●	2

● : Inventory maintained.

(mm)

Order Number	DC	RE	APMX	LU	DN	LF	DCON	Flutes	Stock	Type
AM2SCRBD1200A100R160	12	1.6	15	35	11.4	100	12	2	●	2
AM2SCRBD1200A100R250	12	2.5	15	35	11.4	100	12	2	●	2
AM2SCRBD1200A100R320	12	3.2	15	35	11.4	100	12	2	●	2
AM2SCRBD1200A100R400	12	4	15	35	11.4	100	12	2	●	2
AM2SCRBD1200A125R030	12	0.3	15	40	11.4	125	12	2	●	2
AM2SCRBD1200A125R050	12	0.5	15	40	11.4	125	12	2	●	2
AM2SCRBD1200A125R100	12	1	15	40	11.4	125	12	2	●	2
AM2SCRBD1200A125R160	12	1.6	15	40	11.4	125	12	2	●	2
AM2SCRBD1200A125R250	12	2.5	15	40	11.4	125	12	2	●	2
AM2SCRBD1200A125R320	12	3.2	15	40	11.4	125	12	2	●	2
AM2SCRBD1200A125R400	12	4	15	40	11.4	125	12	2	●	2
AM2SCRBD1600A075R100	16	1	15	30	15.4	75	16	2	●	2
AM2SCRBD1600A075R160	16	1.6	15	30	15.4	75	16	2	●	2
AM2SCRBD1600A075R250	16	2.5	15	30	15.4	75	16	2	●	2
AM2SCRBD1600A075R320	16	3.2	15	30	15.4	75	16	2	●	2
AM2SCRBD1600A075R400	16	4	15	30	15.4	75	16	2	●	2
AM2SCRBD1600A100R100	16	1	15	40	15.4	100	16	2	●	2
AM2SCRBD1600A100R160	16	1.6	15	40	15.4	100	16	2	●	2
AM2SCRBD1600A100R250	16	2.5	15	40	15.4	100	16	2	●	2
AM2SCRBD1600A100R320	16	3.2	15	40	15.4	100	16	2	●	2
AM2SCRBD1600A100R400	16	4	15	40	15.4	100	16	2	●	2
AM2SCRBD1600A125R100	16	1	15	45	15.4	125	16	2	●	2
AM2SCRBD1600A125R160	16	1.6	15	45	15.4	125	16	2	●	2
AM2SCRBD1600A125R250	16	2.5	15	45	15.4	125	16	2	●	2
AM2SCRBD1600A125R320	16	3.2	15	45	15.4	125	16	2	●	2
AM2SCRBD1600A125R400	16	4	15	45	15.4	125	16	2	●	2
AM2SCRBD2000A100R100	20	1	20	40	18.0	100	20	2	●	2
AM2SCRBD2000A100R160	20	1.6	20	40	18.0	100	20	2	●	2
AM2SCRBD2000A100R250	20	2.5	20	40	18.0	100	20	2	●	2
AM2SCRBD2000A100R320	20	3.2	20	40	18.0	100	20	2	●	2
AM2SCRBD2000A100R400	20	4	20	40	18.0	100	20	2	●	2
AM2SCRBD2000A125R100	20	1	20	50	18.0	125	20	2	●	2
AM2SCRBD2000A125R160	20	1.6	20	50	18.0	125	20	2	●	2
AM2SCRBD2000A125R250	20	2.5	20	50	18.0	125	20	2	●	2
AM2SCRBD2000A125R320	20	3.2	20	50	18.0	125	20	2	●	2
AM2SCRBD2000A125R400	20	4	20	50	18.0	125	20	2	●	2

SOLID END MILLS

SQUARE

BALL

RADIUS

TAPER

BARREL

ROUGHING

AM2SCRB

Corner radius end mill, Short cut length, Relieved neck, 2 flute

CARBIDE

—

SOLID END MILLS

SQUARE

BALL

RADIUS

TAPER

BARREL

ROUGHING

RECOMMENDED CUTTING CONDITIONS

Work material	N		
	Aluminium alloy		
	Dia. DC (mm)	Revolution (min ⁻¹)	Feed rate (mm/min)
Side milling			Slotting
3	40000	1800	1600
4	36000	2400	2100
5	30000	3000	2700
6	27000	3200	2800
8	20000	3400	3000
10	16000	3600	3200
12	13000	3600	3200
16	10000	3600	3200
20	8000	3300	3000

Depth of cut			DC: Dia.
--------------	--	--	----------

Note 1) This table shows the cutting condition with less than 4DC overhang length. If more than 4DC, spindle speed, feed rate and depth of cut should be reduced.

Note 2) If the rigidity of the machine or the workpiece installation is very low, or chattering and noise are generated, please reduce the revolution and the feed rate proportionately.

Note 3) Water-soluble cutting fluid is recommended.

Note 4) Climb cutting is recommended for side milling.

AM3SSRB

Corner radius end mill, Short cut length, Relieved neck, 3 flute



CARBIDE

Carbon Steel, Alloy Steel, Cast Iron (<30HRC)	Tool Steel, Pre-Hardened Steel, Hardened Steel (≤45HRC)	Hardened Steel (≤55HRC)	Hardened Steel (>55HRC)	Austenitic Stainless Steel	Titanium Alloy, Heat Resistant Alloy	Copper Alloy	Aluminium Alloy
						○	◎

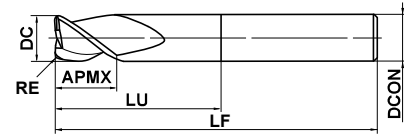

Type1



DC ≤ 12	DC > 12			
0	0			
- 0.020	- 0.030			

● High efficiency machining of aluminium alloy.

(mm)

Order Number	DC	RE	APMX	LU	LF	DCON	Flutes	Stock	Type
AM3SSRBD1200A075R100	12	1	15	30	75	12	3	●	1
AM3SSRBD1200A075R160	12	1.6	15	30	75	12	3	●	1
AM3SSRBD1200A075R250	12	2.5	15	30	75	12	3	●	1
AM3SSRBD1200A075R320	12	3.2	15	30	75	12	3	●	1
AM3SSRBD1200A075R400	12	4	15	30	75	12	3	●	1
AM3SSRBD1200A100R100	12	1	15	35	100	12	3	●	1
AM3SSRBD1200A100R160	12	1.6	15	35	100	12	3	●	1
AM3SSRBD1200A100R250	12	2.5	15	35	100	12	3	●	1
AM3SSRBD1200A100R320	12	3.2	15	35	100	12	3	●	1
AM3SSRBD1200A100R400	12	4	15	35	100	12	3	●	1
AM3SSRBD1200A125R100	12	1	15	40	125	12	3	●	1
AM3SSRBD1200A125R160	12	1.6	15	40	125	12	3	●	1
AM3SSRBD1200A125R250	12	2.5	15	40	125	12	3	●	1
AM3SSRBD1200A125R320	12	3.2	15	40	125	12	3	●	1
AM3SSRBD1200A125R400	12	4	15	40	125	12	3	●	1
AM3SSRBD1600A075R100	16	1	15	30	75	16	3	●	1
AM3SSRBD1600A075R160	16	1.6	15	30	75	16	3	●	1
AM3SSRBD1600A075R250	16	2.5	15	30	75	16	3	●	1
AM3SSRBD1600A075R320	16	3.2	15	30	75	16	3	●	1
AM3SSRBD1600A075R400	16	4	15	30	75	16	3	●	1
AM3SSRBD1600A100R100	16	1	15	40	100	16	3	●	1
AM3SSRBD1600A100R160	16	1.6	15	40	100	16	3	●	1
AM3SSRBD1600A100R250	16	2.5	15	40	100	16	3	●	1
AM3SSRBD1600A100R320	16	3.2	15	40	100	16	3	●	1
AM3SSRBD1600A100R400	16	4	15	40	100	16	3	●	1
AM3SSRBD1600A125R100	16	1	15	45	125	16	3	●	1
AM3SSRBD1600A125R160	16	1.6	15	45	125	16	3	●	1
AM3SSRBD1600A125R250	16	2.5	15	45	125	16	3	●	1
AM3SSRBD1600A125R320	16	3.2	15	45	125	16	3	●	1
AM3SSRBD1600A125R400	16	4	15	45	125	16	3	●	1
AM3SSRBD2000A100R100	20	1	20	40	100	20	3	●	1
AM3SSRBD2000A100R160	20	1.6	20	40	100	20	3	●	1
AM3SSRBD2000A100R250	20	2.5	20	40	100	20	3	●	1
AM3SSRBD2000A100R320	20	3.2	20	40	100	20	3	●	1

SOLID END MILLS

SQUARE

BALL

RADIUS

TAPER

BARREL

ROUGHING

● : Inventory maintained.

ALIMASTER END MILLS

AM3SSRB

Corner radius end mill, Short cut length, Relieved neck, 3 flute

(mm)

Order Number	DC	RE	APMX	LU	LF	DCON	Flutes	Stock	Type
AM3SSRBD2000A100R400	20	4	20	40	100	20	3	●	1
AM3SSRBD2000A125R100	20	1	20	60	125	20	3	●	1
AM3SSRBD2000A125R160	20	1.6	20	60	125	20	3	●	1
AM3SSRBD2000A125R250	20	2.5	20	60	125	20	3	●	1
AM3SSRBD2000A125R320	20	3.2	20	60	125	20	3	●	1
AM3SSRBD2000A125R400	20	4	20	60	125	20	3	●	1
AM3SSRBD2000A150R100	20	1	20	85	150	20	3	●	1
AM3SSRBD2000A150R160	20	1.6	20	85	150	20	3	●	1
AM3SSRBD2000A150R250	20	2.5	20	85	150	20	3	●	1
AM3SSRBD2000A150R320	20	3.2	20	85	150	20	3	●	1
AM3SSRBD2000A150R400	20	4	20	85	150	20	3	●	1
AM3SSRBD2500A100R160	25	1.6	20	50	100	25	3	●	1
AM3SSRBD2500A100R250	25	2.5	20	50	100	25	3	●	1
AM3SSRBD2500A100R320	25	3.2	20	50	100	25	3	●	1
AM3SSRBD2500A100R400	25	4	20	50	100	25	3	●	1
AM3SSRBD2500A100R500	25	5	20	50	100	25	3	●	1
AM3SSRBD2500A125R160	25	1.6	20	65	125	25	3	●	1
AM3SSRBD2500A125R250	25	2.5	20	65	125	25	3	●	1
AM3SSRBD2500A125R320	25	3.2	20	65	125	25	3	●	1
AM3SSRBD2500A125R400	25	4	20	65	125	25	3	●	1
AM3SSRBD2500A125R500	25	5	20	65	125	25	3	●	1
AM3SSRBD2500A150R160	25	1.6	20	90	150	25	3	●	1
AM3SSRBD2500A150R250	25	2.5	20	90	150	25	3	●	1
AM3SSRBD2500A150R320	25	3.2	20	90	150	25	3	●	1
AM3SSRBD2500A150R400	25	4	20	90	150	25	3	●	1
AM3SSRBD2500A150R500	25	5	20	90	150	25	3	●	1

RECOMMENDED CUTTING CONDITIONS

N			
Work material	Aluminium alloy		
Dia. DC (mm)	Revolution (min ⁻¹)	Feed rate (mm/min)	
		Side milling	Slotting
12	13000	5400	3200
16	10000	5400	3200
20	8000	5000	3000
25	6000	4500	2800

Depth of cut		
	DC: Dia.	

Note 1) This table shows the cutting condition with less than 4DC overhang length. If more than 4DC, spindle speed, feed rate and depth of cut should be reduced.

Note 2) If the rigidity of the machine or the workpiece installation is very low, or chattering and noise are generated, please reduce the revolution and the feed rate proportionately.

Note 3) Water-soluble cutting fluid is recommended.

Note 4) Climb cutting is recommended for side milling.

Note 5) Vertical feed is not recommended. To enter the work ramping should be used.

● : Inventory maintained.

AMSR

Roughing end mill, Short cut length, Relieved neck, 3 flute

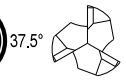

CARBIDE

Carbon Steel, Alloy Steel, Cast Iron (<30HRC)	Tool Steel, Pre-Hardened Steel, Hardened Steel (≤45HRC)	Hardened Steel (≤55HRC)	Hardened Steel (>55HRC)	Austenitic Stainless Steel	Titanium Alloy, Heat Resistant Alloy	Copper Alloy	Aluminium Alloy
---	---	-------------------------	-------------------------	----------------------------	--------------------------------------	--------------	-----------------

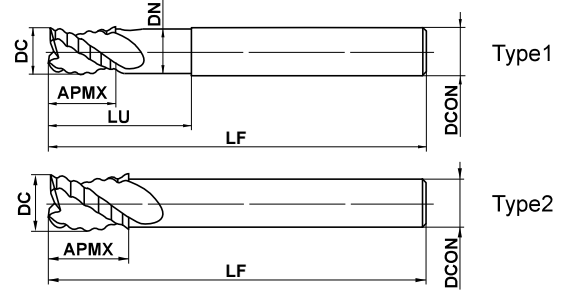

SOLID END MILLS

● Uncoated end mill for roughing aluminium alloy.

(mm)

Order Number	DC	APMX	LU	DN	LF	DCON	Flutes	Stock	Type
AMSRD1000	10	12	25	9.4	75	10	3	●	1
AMSRD1200	12	15	30	11.4	75	12	3	●	1
AMSRD1600	16	18	35	15.4	100	16	3	●	1
AMSRD1800	18	22	—	—	100	16	3	●	2
AMSRD2000	20	25	50	18.0	125	20	3	●	1
AMSRD2200	22	25	—	—	125	20	3	●	2
AMSRD2500	25	30	60	23.0	125	25	3	●	1

SQUARE

BALL

RADIUS

TAPER

BARREL

ROUGHING

RECOMMENDED CUTTING CONDITIONS

Shoulder milling

Work material	N			
	Aluminium alloy A7075		Aluminium cast AC4B	
Dia. DC (mm)	Revolution (min ⁻¹)	Feed rate (mm/min)	Revolution (min ⁻¹)	Feed rate (mm/min)
10	19000	8600	9500	3400
12	16000	8200	8000	3200
16	12000	7600	6000	3100
18	10500	7200	5300	2900
20	9500	7100	4800	2900
22	8500	6900	4300	2800
25	7500	6800	3800	2700

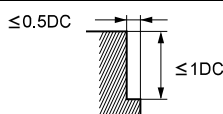
Depth of cut  DC: Dia.

Slotting

Work material	N			
	Aluminium alloy A7075		Aluminium cast AC4B	
Dia. DC (mm)	Revolution (min ⁻¹)	Feed rate (mm/min)	Revolution (min ⁻¹)	Feed rate (mm/min)
10	19000	6800	9500	2700
12	16000	6500	8000	2600
16	12000	6100	6000	2400
18	10500	5800	5300	2400
20	9500	5700	4800	2300
22	8500	5500	4300	2200
25	7500	5400	3800	2200

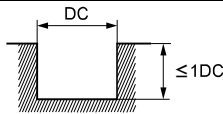
Depth of cut  DC: Dia.

- Note 1) If the rigidity of the machine or the workpiece installation is very low, or chattering and noise are generated, please reduce the revolution and the feed rate proportionately, or set a smaller depth of cut.
 Note 2) If the depth of cut is shallow, the revolution and feed rate can be increased.
 Note 3) Water-soluble cutting fluid is recommended.
 Note 4) Climb cutting is recommended for side milling.

Using a high-speed and high-rigidity machining centre

Shoulder milling

Work material	N			
	Aluminium alloy A7075		Aluminium cast AC4B	
Dia. DC (mm)	Revolution (min ⁻¹)	Feed rate (mm/min)	Revolution (min ⁻¹)	Feed rate (mm/min)
10	30000	11000	19000	5400
12	30000	12000	16000	5300
16	24000	12000	12000	4900
18	21000	12000	10500	4700
20	19000	11000	9500	4600
22	17000	11000	8500	4300
25	15000	11000	7500	4300

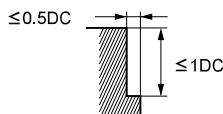
Depth of cut  DC: Dia.

Slotting

Work material	N			
	Aluminium alloy A7075		Aluminium cast AC4B	
Dia. DC (mm)	Revolution (min ⁻¹)	Feed rate (mm/min)	Revolution (min ⁻¹)	Feed rate (mm/min)
10	30000	8600	19000	4300
12	30000	9900	16000	4300
16	24000	9700	12000	4000
18	21000	9500	10500	3800
20	19000	9100	9500	3700
22	17000	8700	8500	3400
25	15000	8600	7500	3400

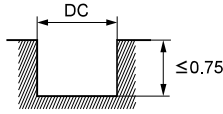
Depth of cut  DC: Dia.

- Note 1) If the rigidity of the machine or the workpiece installation is very low, or chattering and noise are generated, please reduce the revolution and the feed rate proportionately, or set a smaller depth of cut.
 Note 2) If the depth of cut is shallow, the revolution and feed rate can be increased.
 Note 3) Water-soluble cutting fluid is recommended.
 Note 4) Climb cutting is recommended for side milling.

AMMR

Roughing end mill, Medium cut length, Relieved neck, 3 flute

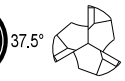

CARBIDE

Carbon Steel, Alloy Steel, Cast Iron (<30HRC)	Tool Steel, Pre-Hardened Steel, Hardened Steel (≤45HRC)	Hardened Steel (≤55HRC)	Hardened Steel (>55HRC)	Austenitic Stainless Steel	Titanium Alloy, Heat Resistant Alloy	Copper Alloy	Aluminium Alloy
						○	◎

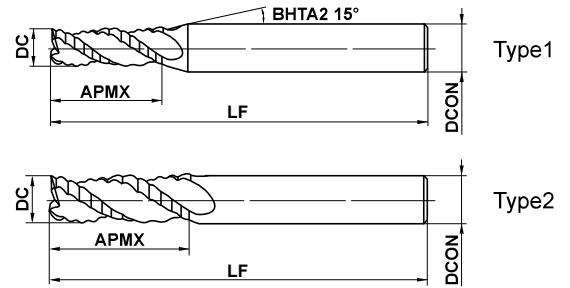

SOLID END MILLS

● Uncoated end mill for roughing aluminium alloy.

(mm)

Order Number	DC	APMX	LF	DCON	Flutes	Stock	Type
AMMRD0300	3	8	50	6	3	□	1
AMMRD0400	4	11	50	6	3	□	1
AMMRD0500	5	13	50	6	3	●	1
AMMRD0600	6	13	50	6	3	●	2
AMMRD0800	8	19	60	8	3	●	2
AMMRD1000	10	22	75	10	3	●	2
AMMRD1200	12	26	75	12	3	●	2
AMMRD1600	16	32	100	16	3	●	2
AMMRD2000	20	38	125	20	3	●	2
AMMRD2500	25	45	125	25	3	●	2

SQUARE

BALL

RADIUS

TAPER

BARREL

ROUGHING

● : Inventory maintained. □ : Non stock, produced to order only.

RECOMMENDED CUTTING CONDITIONS

Shoulder milling

Work material	N			
	Aluminium alloy A7075		Aluminium cast AC4B	
Dia. DC (mm)	Revolution (min ⁻¹)	Feed rate (mm/min)	Revolution (min ⁻¹)	Feed rate (mm/min)
3	40000	2700	25000	1100
4	36000	2700	20000	1100
5	30000	5400	16000	2200
6	27000	6100	13000	2300
8	20000	6000	10000	2400
10	16000	5800	8000	2300
12	13000	5300	6500	2100
16	10000	5100	5000	2000
20	8000	4800	4000	1900
25	6400	4600	3200	1800

Depth of cut			DC: Dia.

Slotting

Work material	N			
	Aluminium alloy A7075		Aluminium cast AC4B	
Dia. DC (mm)	Revolution (min ⁻¹)	Feed rate (mm/min)	Revolution (min ⁻¹)	Feed rate (mm/min)
3	30000	1800	16000	700
4	24000	2200	12000	900
5	19000	2300	10000	900
6	16000	2400	8000	1000
8	12000	2500	6000	1000
10	9500	2600	5000	1100

Depth of cut			DC: Dia.

Note 1) If the rigidity of the machine or the workpiece installation is very low, or chattering and noise are generated, please reduce the revolution and the feed rate proportionately, or set a smaller depth of cut.

Note 2) If the depth of cut is shallow, the revolution and feed rate can be increased.

Note 3) Water-soluble cutting fluid is recommended.

Note 4) Climb cutting is recommended for side milling.

UNCOATED CARBIDE END MILLS

C4LATB

Ball nose taper end mill, Long cut length, For aluminium impellers, 4 flute



CARBIDE

Carbon Steel, Alloy Steel, Cast Iron (<30HRC)	Tool Steel, Pre-Hardened Steel, Hardened Steel (≤45HRC)	Hardened Steel (≤55HRC)	Hardened Steel (>55HRC)	Austenitic Stainless Steel	Titanium Alloy, Heat Resistant Alloy	Copper Alloy	Aluminium Alloy
---	---	-------------------------	-------------------------	----------------------------	--------------------------------------	--------------	-----------------

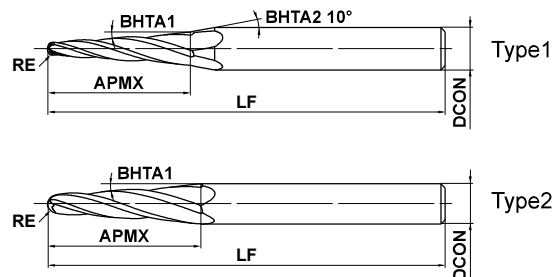

	RE ≤ 2				
	± 0.010				
	± 5'				
	DCON=6	DCON=8			
	0 - 0.008	0 - 0.009			

● High-efficiency roughing for aluminium impellers.

(mm)

Order Number	RE	BHTA1	APMX	LF	DCON	Flutes	Stock	Type
C4LATBR050T040AP20	0.5	4°	20	70	6	4	●	1
C4LATBR100T040AP20	1	4°	20	70	6	4	●	1
C4LATBR150T040AP20	1.5	4°	20	75	8	4	●	1
C4LATBR200T040AP30	2	4°	30	75	8	4	●	2

Note 1) Please inquire with us regarding non-standard special shapes (ex.: RE sizes starting from a minimum of R0.3, half included taper angles) or coatings.

SOLID END MILLS

SQUARE

BALL

RADIUS

TAPER

BARREL

ROUGHING

● : Inventory maintained.

UNCOATED CARBIDE END MILLS

C4LATB

Ball nose taper end mill, Long cut length, For aluminium impellers, 4 flute

RECOMMENDED CUTTING CONDITIONS

Side milling (mm)

Work material	N			
	Revolution (min ⁻¹)	Feed rate (mm/min)	Depth of cut ap	Depth of cut ae
Aluminium alloy				
RE				
R0.5	20000	2000	15	0.75
R1	20000	4000	15	1.5
R1.5	20000	5200	15	2.25
R2	20000	5200	23	3

Depth of cut

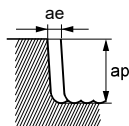

Slotting (mm)

Work material	N		
	Revolution (min ⁻¹)	Feed rate (mm/min)	Depth of cut ap
Aluminium alloy			
RE			
R0.5	20000	600	10
R1	20000	2800	10
R1.5	20000	4000	10
R2	20000	4000	15

Depth of cut

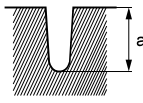

Side Milling (For Finishing) (mm)

Work material	N			
	Revolution (min ⁻¹)	Feed rate (mm/min)	Depth of cut ap	Depth of cut ae
Aluminium alloy				
RE				
R0.5	20000	800	18	0.1
R1	20000	2000	18	0.2
R1.5	20000	2400	18	0.3
R2	20000	2400	27	0.3

Depth of cut

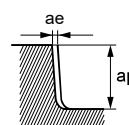

Note 1) Water-soluble cutting fluid is recommended.

Note 2) Climb cutting is recommended for side milling.

Note 3) If the rigidity of the machine or the work materials installation is very low, or chattering and noise are generated, reduce the revolution and feed rate proportionately, or set the depth of cut smaller.

A3SA NEW

End mill, Short cut length, with multiple internal through coolant holes, 3 flute



CARBIDE

Carbon Steel, Alloy Steel, Cast Iron (<30HRC)	Tool Steel, Pre-Hardened Steel, Hardened Steel (<=45HRC)	Hardened Steel (<=55HRC)	Hardened Steel (>55HRC)	Austenitic Stainless Steel	Titanium Alloy, Heat Resistant Alloy	Copper Alloy	Aluminium Alloy
---	--	--------------------------	-------------------------	----------------------------	--------------------------------------	--------------	-----------------

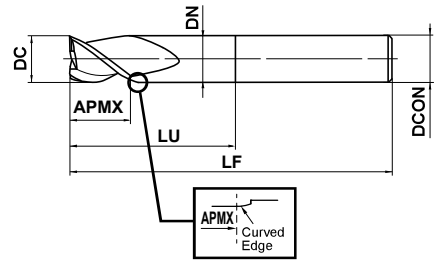

DC=12	DC>12			
0	0			
- 0.020	- 0.030			
12≤DCON≤16	20≤DCON≤25			
0	0			
- 0.011	- 0.013			



- Stability and reliability even when slotting, ramping and plunging.
- The cross sectional geometry of the flutes is perfect for efficient chip discharge.

(mm)

Order Number	DC	APMX	LU	DN	LF	DCON	Flutes	Stock
A3SA120N36C	12	18	36	11.4	80	12	3	●
A3SA160N48C	16	24	48	15.4	90	16	3	●
A3SA200N55C	20	30	55	18	100	20	3	●
A3SA250N55C	25	37.5	55	23	100	25	3	●

SOLID END MILLS

SQUARE

BALL

RADIUS

TAPER

BARREL

ROUGHING

● : Inventory maintained.

A3SARB NEW

Corner radius end mill, Short cut length, with multiple internal through coolant holes, 3 flute



37.5°



Carbon Steel, Alloy Steel, Cast Iron (<30HRC)	Tool Steel, Pre-Hardened Steel, Hardened Steel (≤45HRC)	Hardened Steel (≤55HRC)	Hardened Steel (>55HRC)	Austenitic Stainless Steel	Titanium Alloy, Heat Resistant Alloy	Copper Alloy	Aluminium Alloy
---	---	-------------------------	-------------------------	----------------------------	--------------------------------------	--------------	-----------------

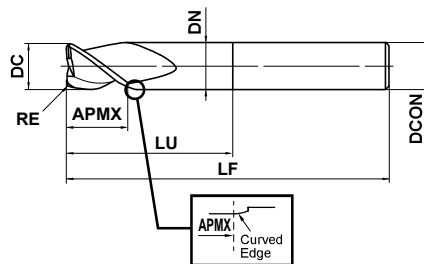

SOLID END MILLS



DC=12	DC>12			
0	0			
-0.020	-0.030			
12≤DCON≤16	20≤DCON≤25			
0	0			
-0.011	-0.013			



- Stability and reliability even when slotting, ramping and plunging.
- The cross sectional geometry of the flutes is perfect for efficient chip discharge.

(mm)

Order Number	DC	RE	APMX	LU	DN	LF	DCON	Flutes	Stock
A3SARB120R100N36C	12	1	18	36	11.4	80	12	3	●
A3SARB120R200N36C	12	2	18	36	11.4	80	12	3	●
A3SARB120R300N36C	12	3	18	36	11.4	80	12	3	●
A3SARB160R200N48C	16	2	24	48	15.4	90	16	3	●
A3SARB160R300N48C	16	3	24	48	15.4	90	16	3	●
A3SARB160R400N48C	16	4	24	48	15.4	90	16	3	●
A3SARB200R200N55C	20	2	30	55	18	100	20	3	●
A3SARB200R300N55C	20	3	30	55	18	100	20	3	●
A3SARB200R400N55C	20	4	30	55	18	100	20	3	●
A3SARB250R200N55C	25	2	37.5	55	23	100	25	3	●
A3SARB250R300N55C	25	3	37.5	55	23	100	25	3	●
A3SARB250R400N55C	25	4	37.5	55	23	100	25	3	●
A3SARB250R500N55C	25	5	37.5	55	23	100	25	3	●

SQUARE

BALL

RADIUS

TAPER

BARREL

ROUGHING

● : Inventory maintained.

A3SA NEW

End mill, Short cut length, 3 flute.
With multiple internal through coolant holes.

A3SARB NEW

Corner radius end mill, Short cut length, 3 flute.
With multiple internal through coolant holes.

CARBIDE

RECOMMENDED CUTTING CONDITIONS

When the rigidity of the machine or workpiece and chip discharge are sufficient, use high efficiency conditions.
When the rigidity of the machine or workpiece or chip discharge is insufficient, use general-purpose conditions.

High Efficiency Conditions

Side Milling

N					
Work material	Aluminium Alloys				
Dia. DC (mm)	Cutting Speed (m/min)	Revolution (min ⁻¹)	Feed Rate (mm/min)	Depth of cut ap (mm)	Depth of Cut ae (mm)
12	1240	33000	15000	12	6
16	1660	33000	20000	16	8
20	2070	33000	26000	20	10
25	2590	33000	32000	25	12.5

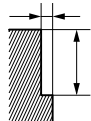
Depth of Cut 

Slot Milling

N				
Work material	Aluminium Alloys			
Dia. DC (mm)	Cutting Speed (m/min)	Revolution (min ⁻¹)	Feed Rate (mm/min)	Depth of Cut ap (mm)
12	1240	33000	15000	6
16	1660	33000	20000	8
20	2070	33000	26000	10
25	2590	33000	32000	12.5

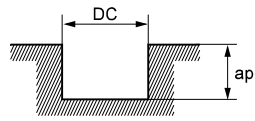
Depth of Cut  DC: Cutting Dia.

General-purpose Conditions

Side Milling

N					
Work material	Aluminium Alloys				
Dia. DC (mm)	Cutting Speed (m/min)	Revolution (min ⁻¹)	Feed Rate (mm/min)	Depth of cut ap (mm)	Depth of Cut ae (mm)
12	600	16000	7200	12	6
16	600	12000	7200	16	8
20	600	9500	7400	20	10
25	600	7600	7300	25	12.5

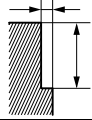
Depth of Cut 

Slot Milling

N				
Work material	Aluminium Alloys			
Dia. DC (mm)	Cutting Speed (m/min)	Revolution (min ⁻¹)	Feed Rate (mm/min)	Depth of Cut ap (mm)
12	600	16000	7200	6
16	600	12000	7200	8
20	600	9500	7400	10
25	600	7600	7300	12.5

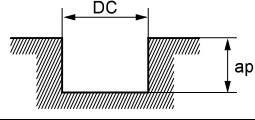
Depth of Cut  DC: Cutting Dia.

Note 1) It is recommended to use a water-soluble coolant. It is also possible to use an air blower (outer/inner) for DLC coating.

Note 2) Climb milling is recommended for side cutting.

Note 3) This table shows the cutting condition with less than 4D overhang length. If more than 4D, spindle speed, feed rate and depth of cut should be reduced.

Note 4) When ramping, consider the chip discharge and reduce the feed rate of the slotting conditions by 50% and use a ramping angle of 5° or less.

Note 5) If the rigidity of the machine or the workpiece materials installation is very low, or chattering and noise are generated, reduce the revolution and feed rate proportionately within the range described in the above table, or reduce the depth and width of cut.

SOLID END MILLS

SQUARE

BALL

RADIUS

TAPER

BARREL

ROUGHING

DLC4LATB NEW

Ball nose taper end mill, Long cut length, For aluminium impellers, 4 flute



Carbon Steel, Alloy Steel, Cast Iron (<30HRC)	Tool Steel, Pre-Hardened Steel, Hardened Steel (≤45HRC)	Hardened Steel (≤55HRC)	Hardened Steel (>55HRC)	Austenitic Stainless Steel	Titanium Alloy, Heat Resistant Alloy	Copper Alloy	Aluminium Alloy
---	---	-------------------------	-------------------------	----------------------------	--------------------------------------	--------------	-----------------

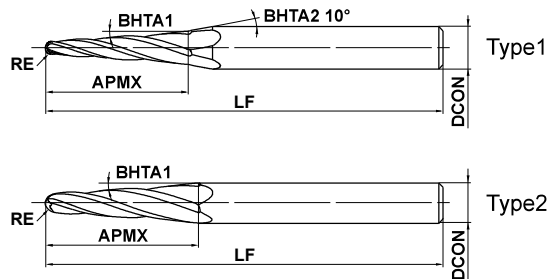

	RE ≤ 2				
	± 0.010				
	± 5°				
	DCON=6	DCON=8			
	$\begin{matrix} 0 \\ -0.008 \end{matrix}$	$\begin{matrix} 0 \\ -0.009 \end{matrix}$			

- The high-rigidity design with improved breakage resistance achieves high-efficiency machining of aluminium alloy impellers.
- High resistance to welding when there is an insufficient coolant supply or during high-speed cutting.

(mm)

Order Number	RE	BHTA1	APMX	LF	DCON	Flutes	Stock	Type
DLC4LATBR050T040AP20	0.5	4°	20	70	6	4	●	1
DLC4LATBR100T040AP20	1	4°	20	70	6	4	●	1
DLC4LATBR150T040AP20	1.5	4°	20	75	8	4	●	1
DLC4LATBR200T040AP30	2	4°	30	75	8	4	●	2

Note 1) A wide range of non-standard coatings or shapes are available, e.g. RE sizes starting from a minimum of R0.3, half included taper angles etc. Please contact us for more information.

● : Inventory maintained.

RECOMMENDED CUTTING CONDITIONS

Side Milling (mm)

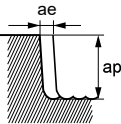
		N			
Work material	Aluminium Alloys				
R RE	Revolution (min ⁻¹)	Feed rate (mm/min)	Depth of cut ap	Depth of cut ae	
R0.5	20000	2000	15	0.75	
R1	20000	4000	15	1.5	
R1.5	20000	5200	15	2.25	
R2	20000	5200	23	3	
Depth of cut					

Slotting (mm)

		N		
Work material	Aluminium Alloys			
R RE	Revolution (min ⁻¹)	Feed rate (mm/min)	Depth of cut ap	
R0.5	20000	600	10	
R1	20000	2800	10	
R1.5	20000	4000	10	
R2	20000	4000	15	
Depth of cut				

Side Milling (Finishing) (mm)

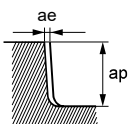
		N			
Work material	Aluminium Alloys				
R RE	Revolution (min ⁻¹)	Feed rate (mm/min)	Depth of cut ap	Depth of cut ae	
R0.5	20000	800	18	0.1	
R1	20000	2000	18	0.2	
R1.5	20000	2400	18	0.3	
R2	20000	2400	27	0.3	
Depth of cut					



Case Examples for Non-standard Shapes

Note 1) Water-soluble cutting fluid is recommended.

Note 2) Climb cutting is recommended for side milling.

Note 3) If the rigidity of the machine or the work materials installation is very low, or chattering and noise are generated, reduce the revolution and feed rate proportionately, or set a smaller depth of cut.

DLC3SA NEW

End mill, Short cut length, with multiple internal through coolant holes, 3 flute



Carbon Steel, Alloy Steel, Cast Iron (<30HRC)	Tool Steel, Pre-Hardened Steel, Hardened Steel (≤45HRC)	Hardened Steel (≤55HRC)	Hardened Steel (>55HRC)	Austenitic Stainless Steel	Titanium Alloy, Heat Resistant Alloy	Copper Alloy	Aluminium Alloy
---	---	-------------------------	-------------------------	----------------------------	--------------------------------------	--------------	-----------------

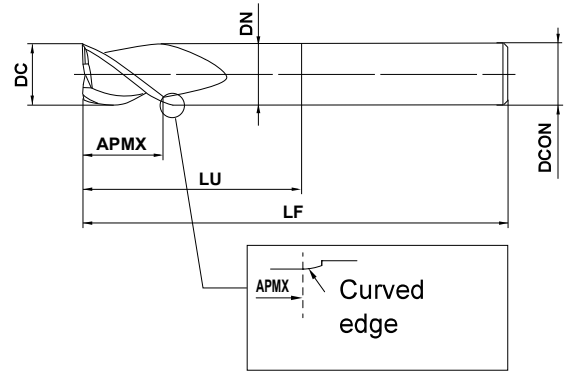

SOLID END MILLS

	DC=12	DC>12			
	0 - 0.020	0 - 0.030			
	12≤DCON≤16	20≤DCON≤25			
	0 - 0.011	0 - 0.013			

- Stability and reliability even when slotting, ramping and plunging.
- The cross sectional geometry of the flutes is perfect for efficient chip discharge.

(mm)

Order Number	DC	APMX	LU	DN	LF	DCON	Flutes	Stock
DLC3SA120N36C	12	18	36	11.4	80	12	3	★
DLC3SA160N48C	16	24	48	15.4	90	16	3	★
DLC3SA200N55C	20	30	55	18	100	20	3	★
DLC3SA250N55C	25	37.5	55	23	100	25	3	★

SQUARE

BALL

RADIUS

TAPER

BARREL

ROUGHING

DLC3SARB NEW

Corner radius end mill, Short cut length, with multiple internal through coolant holes, 3 flute



37.5°



CARBIDE

Carbon Steel, Alloy Steel, Cast Iron (<30HRC)	Tool Steel, Pre-Hardened Steel, Hardened Steel (≤45HRC)	Hardened Steel (≤55HRC)	Hardened Steel (>55HRC)	Austenitic Stainless Steel	Titanium Alloy, Heat Resistant Alloy	Copper Alloy	Aluminium Alloy
---	---	-------------------------	-------------------------	----------------------------	--------------------------------------	--------------	-----------------

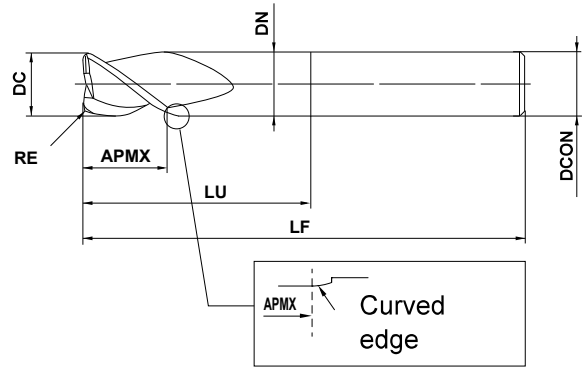

DC=12	DC>12			
0	0			
- 0.020	- 0.030			
12≤DCON≤16	20≤DCON≤25			
0	0			
- 0.011	- 0.013			



- Stability and reliability even when slotting, ramping and plunging.
- The cross sectional geometry of the flutes is perfect for efficient chip discharge.

(mm)

Order Number	DC	RE	APMX	LU	DN	LF	DCON	Flutes	Stock
DLC3SARB120R100N36C	12	1	18	36	11.4	80	12	3	★
DLC3SARB120R200N36C	12	2	18	36	11.4	80	12	3	★
DLC3SARB120R300N36C	12	3	18	36	11.4	80	12	3	★
DLC3SARB160R200N48C	16	2	24	48	15.4	90	16	3	★
DLC3SARB160R300N48C	16	3	24	48	15.4	90	16	3	★
DLC3SARB160R400N48C	16	4	24	48	15.4	90	16	3	★
DLC3SARB200R200N55C	20	2	30	55	18	100	20	3	★
DLC3SARB200R300N55C	20	3	30	55	18	100	20	3	★
DLC3SARB200R400N55C	20	4	30	55	18	100	20	3	★
DLC3SARB250R200N55C	25	2	37.5	55	23	100	25	3	★
DLC3SARB250R300N55C	25	3	37.5	55	23	100	25	3	★
DLC3SARB250R400N55C	25	4	37.5	55	23	100	25	3	★
DLC3SARB250R500N55C	25	5	37.5	55	23	100	25	3	★

SOLID END MILLS

SQUARE

BALL

RADIUS

TAPER

BARREL

ROUGHING

DLC3SA **NEW**End mill, Short cut length, 3 flute.
With multiple internal through coolant holes.**DLC3SARB** **NEW**Corner radius end mill, Short cut length, with multiple internal
through coolant holes, 3 flute**RECOMMENDED CUTTING CONDITIONS****HIGH EFFICIENCY CONDITIONS**

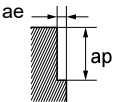
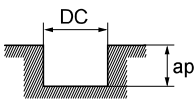
		N					
Work material	Aluminium Alloys						
DC	Revolution (min ⁻¹)	Feed rate (mm/min)	Depth of cut ap	Depth of cut ae	Revolution (min ⁻¹)	Feed rate (mm/min)	Depth of cut ap
12	33000	15000	12	6	33000	15000	6
16	33000	20000	16	8	33000	20000	8
20	33000	26000	20	10	33000	26000	10
25	33000	32000	25	12.5	33000	32000	12.5
Depth of cut							

SOLID END MILLS

SQUARE

BALL

RADIUS

TAPER

BARREL

ROUGHING

GENERAL PURPOSE CONDITIONS

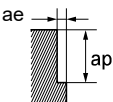
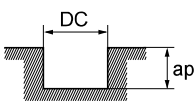
		N					
Work material	Aluminium Alloys						
DC	Revolution (min ⁻¹)	Feed rate (mm/min)	Depth of cut ap	Depth of cut ae	Revolution (min ⁻¹)	Feed rate (mm/min)	Depth of cut ap
12	16000	7200	12	6	33000	7200	6
16	12000	7200	16	8	33000	7200	8
20	9500	7400	20	10	33000	7400	10
25	7600	7300	25	12.5	33000	7300	12.5
Depth of cut							

Note 1) Water-soluble cutting fluid is recommended.

Note 2) Climb milling is recommended for side cutting.

Note 3) When machining with a large tool length protrusion, adjust the the speed, feed and depth of cut as necessary.

Note 4) If the rigidity of the machine or the workpiece materials installation is very low, or chattering and noise are generated, reduce the revolution and feed rate proportionately within the range described in the above table, or reduce the depth and width of cut.

DIAMOND COATED END MILLS

DFC4JC

End mill, Semi long cut length, 4 flute



CARBIDE

CFRP

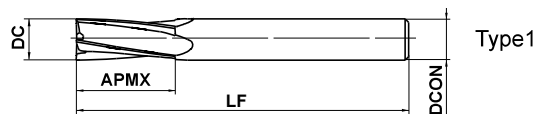

$6 \leq DC \leq 12$				
0				
-0.03				



DCON=6	$8 \leq DCON \leq 10$	DCON=12		
0	0	0		
-0.008	-0.009	-0.011		

● 4 flute end mill with CVD diamond coating for machining CFRP.

(mm)

Order Number	DC	APMX	LF	DCON	Flutes	Stock	Type
DFC4JCD0600	6	20	70	6	4	★	1
DFC4JCD0800	8	30	80	8	4	★	1
DFC4JCD1000	10	30	90	10	4	★	1
DFC4JCD1200	12	30	100	12	4	★	1

RECOMMENDED CUTTING CONDITIONS

Work material	X	
	CFRP	
Dia. DC (mm)	Revolution (min ⁻¹)	Feed rate (mm/min)
6	11000	950
8	8000	780
10	6400	700
12	5300	650

Note 1) Cutting conditions may differ considerably due to the type of CFRP, the rigidity of the machine or the clamping and geometry of the workpiece. Please use the above table as a standard starting point.

Note 2) When high machining accuracy is needed, or large burrs or delamination occurs, we recommend reducing the feed rate.

Note 3) When the depth of cut is greater than 0.8DC, we recommend reducing the feed rate.

Note 4) Please take precautions against dust.

★ : Inventory maintained in Japan.

SOLID END MILLS

SQUARE

BALL

RADIUS

TAPER

BARREL

ROUGHING

DIAMOND COATED END MILLS

DFCJRT

Cross-nick type end mill, Semi long cut length



CFRP

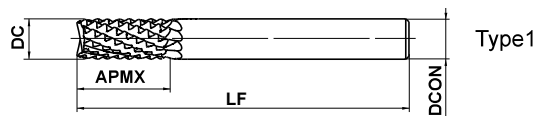

Type1

SOLID END MILLS



DCON=6	8 ≤ DCON ≤ 10	DCON=12		
$\begin{matrix} 0 \\ -0.008 \end{matrix}$	$\begin{matrix} 0 \\ -0.009 \end{matrix}$	$\begin{matrix} 0 \\ -0.011 \end{matrix}$		

● Cross-nick type end mill with original CVD diamond coating for CFRP machining.

(mm)

Order Number	DC	APMX	LF	DCON	Flutes	Stock	Type
DFCJRTD0600	6	20	70	6	10	★	1
DFCJRTD0800	8	30	80	8	10	★	1
DFCJRTD1000	10	30	90	10	12	★	1
DFCJRTD1200	12	30	100	12	12	★	1

SQUARE

BALL

RADIUS

TAPER

BARREL

ROUGHING

RECOMMENDED CUTTING CONDITIONS

Work material	X	
	CFRP	
Dia. DC (mm)	Revolution (min ⁻¹)	Feed rate (mm/min)
6	11000	1200
8	8000	1000
10	6400	900
12	5300	850

Note 1) Cutting conditions may differ considerably due to the type of CFRP, the rigidity of the machine or the clamping and geometry of the workpiece. Please use the above table as a standard starting point.

Note 2) When high machining accuracy is needed or large burrs or delamination occurs, we recommend reducing the feed rate.

Note 3) When the depth of cut is greater than 0.8DC, we recommend reducing the feed rate.

Note 4) Please take precautions against dust.

DF2XLB

Ball nose, Long neck, For graphite, 2 flute



CARBIDE

Aluminium Alloy	Copper Alloy	Graphite	GFRP CFRP	Machineable Ceramics
○	◎	◎	○	○



Effective length
for inclined angle

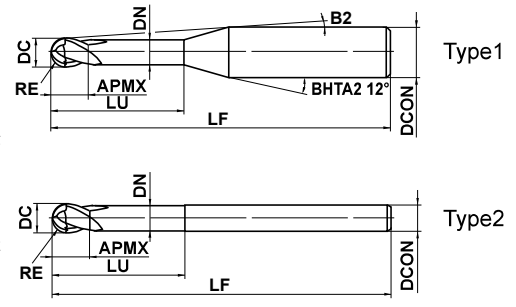
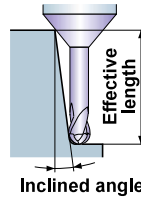

	$0.1 \leq RE \leq 3$				
	± 0.01				
	DCON=4,6				
	$\begin{matrix} 0 \\ -0.008 \end{matrix}$				

● 2 flute long neck ball nose end mill with original diamond coating for machining graphite.

(mm)

Order Number	RE	DC	APMX	LU	DN	B2	LF	DCON	Flutes	Stock	Type	Effective length for inclined angle			
												0.5°	1°	2°	3°
DF2XLBR0015N020	0.15	0.3	0.3	2	0.27	9.9°	50	4	2	●	1	2.1	2.2	2.4	2.6
DF2XLBR0020N040	0.2	0.4	0.6	4	0.36	8.4°	60	4	2	●	1	4.1	4.3	4.7	5.2
DF2XLBR0020N080	0.2	0.4	0.6	8	0.36	6.4°	60	4	2	●	1	8.3	8.7	9.5	10.5
DF2XLBR0025N040	0.25	0.5	0.6	4	0.46	8.3°	60	4	2	●	1	4.1	4.3	4.7	5.2
DF2XLBR0025N080	0.25	0.5	0.6	8	0.46	6.3°	60	4	2	●	1	8.3	8.7	9.5	10.5
DF2XLBR0030N060	0.3	0.6	0.9	6	0.56	7.1°	60	4	2	●	1	6.3	6.5	7.1	7.9
DF2XLBR0030N100	0.3	0.6	0.9	10	0.56	5.5°	60	4	2	●	1	10.4	10.9	11.9	13.2
DF2XLBR0040N080	0.4	0.8	1.2	8	0.76	6.1°	60	4	2	●	1	8.3	8.7	9.5	10.5
DF2XLBR0050N040	0.5	1	1.5	4	0.94	8.0°	60	4	2	●	1	4.2	4.4	4.8	5.3
DF2XLBR0050N100	0.5	1	1.5	10	0.94	5.2°	60	4	2	●	1	10.5	11.0	12.0	13.3
DF2XLBR0050N120	0.5	1	1.5	12	0.94	4.6°	60	4	2	●	1	12.6	13.2	14.4	15.9
DF2XLBR0050N160	0.5	1	1.5	16	0.94	3.8°	80	4	2	●	1	16.8	17.5	19.2	21.3
DF2XLBR0050N200	0.5	1	1.5	20	0.94	3.3°	80	4	2	●	1	21.0	21.9	24.0	26.6
DF2XLBR0050N300	0.5	1	1.5	30	0.94	2.4°	80	4	2	●	1	31.4	32.8	36.0	*
DF2XLBR0075N160	0.75	1.5	2.3	16	1.44	3.4°	80	4	2	●	1	16.8	17.5	19.2	21.2
DF2XLBR0100N160	1	2	3	16	1.9	2.9°	80	4	2	●	1	16.7	17.4	19.0	*
DF2XLBR0100N200	1	2	3	20	1.9	2.5°	80	4	2	●	1	20.9	21.8	23.8	*
DF2XLBR0100N250	1	2	3	25	1.9	2.0°	80	4	2	●	1	26.1	27.2	*	*
DF2XLBR0100N400	1	2	3	40	1.9	1.4°	100	4	2	●	1	41.7	43.5	*	*
DF2XLBR0150N160	1.5	3	4.5	16	2.9	1.7°	80	4	2	●	1	16.7	17.3	*	*
DF2XLBR0150N250	1.5	3	4.5	25	2.9	1.2°	80	4	2	●	1	26.1	27.2	*	*
DF2XLBR0200N300	2	4	6	30	3.9	—	80	4	2	●	2	*	*	*	*
DF2XLBR0200N600	2	4	6	60	3.9	—	100	4	2	●	2	*	*	*	*

* No interference

● : Inventory maintained.

SOLID END MILLS

SQUARE

BALL

RADIUS

TAPER

BARREL

ROUGHING

RECOMMENDED CUTTING CONDITIONS

Work material		X				N			
		Graphite				Copper, Copper alloys			
RE (mm)	Neck length LU (mm)	Revolution (min ⁻¹)	Feed rate (mm/min)	Depth of cut ap (mm)	Depth of cut ae (mm)	Revolution (min ⁻¹)	Feed rate (mm/min)	Depth of cut ap (mm)	Depth of cut ae (mm)
R0.15	2	40000	1200	0.03	0.08	40000	800	0.003	0.03
	3	40000	1200	0.03	0.08	40000	600	0.002	0.03
R0.2	1	40000	1500	0.05	0.15	40000	2000	0.015	0.04
	2	40000	1500	0.05	0.12	40000	1300	0.01	0.04
	3	40000	1300	0.04	0.12	40000	800	0.005	0.04
	4	40000	1300	0.04	0.1	32000	600	0.004	0.04
	8	30000	800	0.03	0.1	—	—	—	—
	12	20000	450	0.03	0.08	—	—	—	—
R0.25	4	40000	1500	0.05	0.15	40000	800	0.01	0.05
	5	38000	1300	0.05	0.15	36000	700	0.008	0.05
	8	30000	1000	0.04	0.12	28000	500	0.002	0.05
R0.3	2	40000	1800	0.07	0.2	40000	1500	0.03	0.06
	4	40000	1500	0.06	0.18	40000	1200	0.02	0.06
	5	40000	1500	0.06	0.17	40000	1100	0.015	0.06
	6	40000	1500	0.06	0.15	40000	1000	0.008	0.06
	8	37000	1200	0.05	0.15	35000	800	0.005	0.06
	10	35000	1000	0.05	0.15	—	—	—	—
	16	22000	530	0.04	0.12	—	—	—	—
R0.4	6	40000	1700	0.08	0.2	40000	1500	0.02	0.08
	8	40000	1700	0.08	0.15	30000	1200	0.008	0.08
R0.5	4	40000	2500	0.12	0.3	40000	2000	0.05	0.1
	6	40000	2500	0.1	0.3	40000	2000	0.03	0.1
	8	40000	2000	0.1	0.25	40000	1800	0.02	0.1
	10	40000	2000	0.1	0.2	33000	1400	0.01	0.1
	12	40000	2000	0.1	0.2	30000	1000	0.007	0.1
	20	30000	1100	0.08	0.2	—	—	—	—
	30	20000	600	0.06	0.15	—	—	—	—
	40	15000	400	0.04	0.12	—	—	—	—
Depth of cut									

Note 1) When high machining accuracy is needed, or the workpiece becomes chipped, we recommend lowering the feed rate.
 Note 2) Use a milling machine dedicated for graphite.
 Note 3) If the rigidity of the machine or the work materials installation is very low, or chattering and noise are generated, reduce the revolution and feed rate proportionately.

SOLID END MILLS
 SQUARE
 BALL
 RADIUS
 TAPER
 BARREL
 ROUGHING

DIAMOND COATED END MILLS

DF2XLB

Ball nose, Long neck, For graphite, 2 flute

CARBIDE

SOLID END MILLS

SQUARE

BALL

RADIUS

TAPER

BARREL

ROUGHING

Work material		X				N			
		Graphite				Copper, Copper alloys			
RE (mm)	Neck length LU (mm)	Revolution (min ⁻¹)	Feed rate (mm/min)	Depth of cut ap (mm)	Depth of cut ae (mm)	Revolution (min ⁻¹)	Feed rate (mm/min)	Depth of cut ap (mm)	Depth of cut ae (mm)
R0.75	8	40000	2800	0.15	0.45	40000	2400	0.07	0.15
	10	40000	2800	0.15	0.45	32000	1800	0.05	0.15
	16	35000	2000	0.15	0.3	20000	900	0.03	0.15
	30	27000	1000	0.1	0.3	—	—	—	—
	40	21000	700	0.08	0.25	—	—	—	—
R1	8	40000	3000	0.23	0.7	40000	3000	0.1	0.2
	10	40000	3000	0.2	0.6	40000	2800	0.08	0.2
	12	35000	2500	0.2	0.6	35000	2300	0.08	0.2
	16	30000	2000	0.2	0.5	30000	1800	0.05	0.2
	20	30000	2000	0.2	0.5	20000	1200	0.04	0.2
	25	25000	1500	0.18	0.45	20000	1000	0.03	0.2
	40	20000	1000	0.15	0.4	—	—	—	—
R1.5	16	28000	3000	0.3	0.9	28000	3000	0.3	0.3
	25	20000	2000	0.25	0.75	20000	2000	0.25	0.3
	40	16000	1500	0.2	0.6	16000	1500	0.2	0.3
	60	14000	1000	0.17	0.45	—	—	—	—
R2	8	24000	3800	0.5	1.5	24000	3800	0.5	0.4
	20	21000	3300	0.5	1.5	21000	3300	0.4	0.4
	30	15000	2000	0.4	1.2	15000	2000	0.3	0.4
	40	13000	1600	0.35	1.0	13000	1600	0.25	0.4
	60	12000	1400	0.3	0.9	12000	1400	0.2	0.4
Depth of cut									

Note 1) When high machining accuracy is needed, or the workpiece becomes chipped, we recommend lowering the feed rate.

Note 2) Use a milling machine dedicated for graphite.

Note 3) If the rigidity of the machine or the work materials installation is very low, or chattering and noise are generated, reduce the revolution and feed rate proportionately.

DIAMOND COATED END MILLS

DF2XLBF

Ball nose, Medium cut length, Long neck, For Finishing, 2 flute



Aluminium Alloy	Copper Alloy	Graphite	Zirconia (Before Sintering)	Rigid Composite Resin (Composite Resin)	Machineable Ceramics
○	◎	◎	◎	◎	○

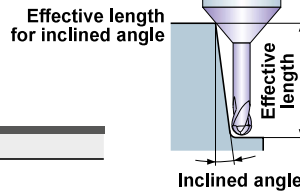
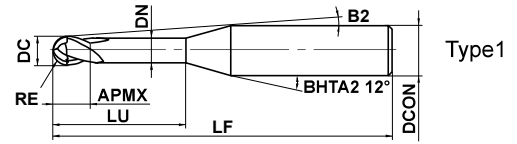

	$0.3 \leq RE \leq 1$	$1.5 \leq RE$			
	± 0.005	± 0.01			
	DCON=4				
	0				
	- 0.008				

● Diamond coated long-neck ball end mills, ideal for achieving excellent surface finishes on non-ferrous materials.

(mm)

Order Number	RE	DC	APMX	LU	DN	B2	LF	DCON	Flutes	Stock	Type	Effective length for inclined angle			
												0.5°	1°	2°	3°
DF2XLBFR0030N100	0.3	0.6	0.45	10	0.57	5.5°	50	4	2	●	1	10.4	10.9	11.9	13.2
DF2XLBFR0050N120	0.5	1	1.5	12	0.86	4.6°	50	4	2	●	1	12.6	13.2	14.4	15.9
DF2XLBFR0050N160	0.5	1	1.5	16	0.86	3.8°	50	4	2	●	1	16.8	17.5	19.2	21.3
DF2XLBFR0050N200	0.5	1	1.5	20	0.86	3.2°	50	4	2	●	1	21	21.9	24	26.6
DF2XLBFR0100N160	1	2	3	16	1.86	2.9°	50	4	2	●	1	16.7	17.4	19	*
DF2XLBFR0100N200	1	2	3	20	1.86	2.4°	50	4	2	●	1	20.9	21.8	23.9	*
DF2XLBFR0150N160	1.5	3	4.5	16	2.86	1.7°	50	4	2	●	1	16.7	17.3	18.9	20.8
DF2XLBFR0150N200	1.5	3	4.5	20	2.86	1.4°	50	4	2	●	1	20.8	21.7	23.7	26.1

* No interference

● : Inventory maintained.

SOLID END MILLS

SQUARE

BALL

RADIUS

TAPER

BARREL

ROUGHING

—

DIAMOND COATED END MILLS

DF2XLBF

Ball nose, Medium cut length, Long neck, For Finishing, 2 flute

CARBIDE

RECOMMENDED CUTTING CONDITIONS

Work material		X							
		Graphite				Zirconia (Before Sintering)			
RE (mm)	Neck length LU (mm)	Revolution (min ⁻¹)	Feed rate (mm/min)	Depth of cut ap (mm)	Depth of cut ae (mm)	Revolution (min ⁻¹)	Feed rate (mm/min)	Depth of cut ap (mm)	Depth of cut ae (mm)
R0.3	10	35000	1000	0.05	0.015	26000	600	0.06	0.03
	12	40000	2000	0.10	0.200	26000	600	0.10	0.05
R0.5	16	35000	1500	0.09	0.200	26000	600	0.08	0.04
	20	30000	1100	0.08	0.200	26000	600	0.08	0.04
R1	16	30000	2000	0.20	0.500	18000	1400	0.06	0.80
	20	30000	2000	0.20	0.500	18000	1200	0.50	0.60
R1.5	16	28000	3000	0.30	0.900	15000	1600	0.90	0.90
	20	25000	2500	0.20	0.900	15000	1400	0.60	0.80

SOLID END MILLS

Work material		X				N			
		Rigid Composite Resin (Composite Resin)				Copper, Copper Alloys			
RE (mm)	Neck length LU (mm)	Revolution (min ⁻¹)	Feed rate (mm/min)	Depth of cut ap (mm)	Depth of cut ae (mm)	Revolution (min ⁻¹)	Feed rate (mm/min)	Depth of cut ap (mm)	Depth of cut ae (mm)
R0.3	10	28000	450	0.050	0.050	30000	600	0.005	0.040
	12	25000	900	0.100	0.100	33000	1400	0.010	0.100
R0.5	16	25000	700	0.080	0.080	25000	800	0.007	0.080
	20	25000	600	0.080	0.080	20000	500	0.005	0.050
R1	16	25000	2100	0.800	0.800	30000	1800	0.050	0.200
	20	25000	1800	0.500	0.500	20000	1200	0.040	0.200
R1.5	16	25000	2400	1.000	1.000	28000	3000	0.300	0.300
	20	25000	2100	0.800	0.800	25000	2500	0.200	0.300

SQUARE

BALL

RADIUS

TAPER

BARREL

ROUGHING

Note 1) When high machining accuracy is needed, or the work materials becomes chipped, we recommend lowering the feed rate.

Note 2) Use a milling machine suitable for graphite machining.

Note 3) If the rigidity of the machine or the work materials installation is very low, or chattering and noise are generated, reduce the revolution and feed rate proportionately.

Note 4) When dry machining work materials that contain resin, beware build up of chips that may cause breakage.

DIAMOND COATED END MILLS

DF4JC

End mill, Semi long cut length, For graphite, 4 flute



Aluminium Alloy	Copper Alloy	Graphite	GFRP CFRP	Machineable Ceramics
○	◎	◎	○	○

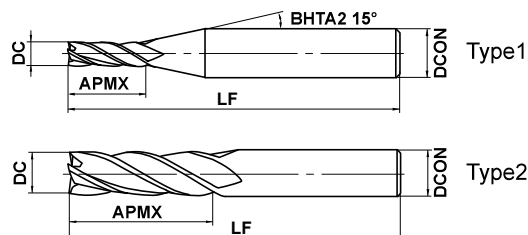

SOLID END MILLS

	$3 \leq DC \leq 12$				
	0 - 0.02				
	DCON=6	$8 \leq DCON \leq 10$	DCON=12		
	0 - 0.008	0 - 0.009	0 - 0.011		

● 4 flute end mill with original diamond coating for machining graphite.

(mm)

Order Number	DC	APMX	LF	DCON	Flutes	Stock	Type
DF4JCD0300	3	12	60	6	4	●	1
DF4JCD0400	4	16	60	6	4	●	1
DF4JCD0600	6	24	60	6	4	●	2
DF4JCD0800	8	28	70	8	4	●	2
DF4JCD1000	10	35	90	10	4	●	2
DF4JCD1200	12	36	110	12	4	●	2

SQUARE

BALL

RADIUS

TAPER

BARREL

ROUGHING

RECOMMENDED CUTTING CONDITIONS

Work material	X				N			
	Graphite				Copper, Copper alloys			
Dia. DC (mm)	Revolution (min ⁻¹)	Feed rate (mm/min)	Depth of cut ap (mm)	Depth of cut ae (mm)	Revolution (min ⁻¹)	Feed rate (mm/min)	Depth of cut ap (mm)	Depth of cut ae (mm)
3	22000	2500	6	0.15	10600	280	6	0.15
4	18000	2900	8	0.2	8000	330	8	0.2
6	14000	3200	12	0.3	6400	380	12	0.3
8	10500	2900	16	0.4	4000	420	16	0.4
10	8700	2600	20	0.5	3200	460	20	0.5
12	7200	2200	24	0.6	2700	460	24	0.6

Depth of cut

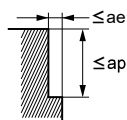

D: Dia.

Note 1) When high machining accuracy is needed, or the workpiece becomes chipped, we recommend lowering the feed rate.

Note 2) Use a milling machine dedicated for graphite.

Note 3) If the rigidity of the machine or the work materials installation is very low, or chattering and noise are generated, reduce the revolution and feed rate proportionately.

● : Inventory maintained.

DC2SB

Ball nose, Short cut length, For hard brittle materials, 2 flute



CARBIDE

Cemented Carbide	Alumina Zirconia	Silicon Carbide Silicon Nitride	Quartz Glass
○	○	○	○

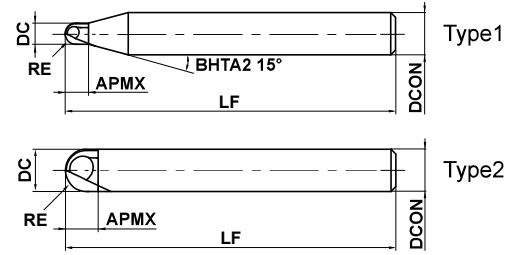

$0.1 \leq RE \leq 3$

± 0.01



$4 \leq DCON \leq 6$

$\begin{matrix} 0 \\ - 0.008 \end{matrix}$

● DC ball nose end mill for machining carbide and other hard brittle materials.

(mm)

Order Number	RE	DC	APMX	LF	DCON	Flutes	Stock	Type
DC2SBR0010	0.1	0.2	0.12	50	4	2	●	1
DC2SBR0020	0.2	0.4	0.24	50	4	2	●	1
DC2SBR0030	0.3	0.6	0.42	50	4	2	●	1
DC2SBR0040	0.4	0.8	0.56	50	4	2	●	1
DC2SBR0050	0.5	1	0.7	50	4	2	●	1
DC2SBR0075	0.75	1.5	1	50	4	2	●	1
DC2SBR0100	1	2	1.4	50	4	2	●	1
DC2SBR0150	1.5	3	2.1	60	6	2	●	1
DC2SBR0200	2	4	2.8	60	6	2	●	1
DC2SBR0250	2.5	5	3.5	60	6	2	●	1
DC2SBR0300	3	6	4.2	60	6	2	●	2

SOLID END MILLS

SQUARE

BALL

RADIUS

TAPER

BARREL

ROUGHING

● : Inventory maintained.

RECOMMENDED CUTTING CONDITIONS

Work material		X							
		Cemented Carbide				Alumina Zirconia			
Dia. DC (mm)	RE (mm)	Revolution (min ⁻¹)	Feed rate (mm/min)	Depth of cut ap (mm)	Depth of cut ae (mm)	Revolution (min ⁻¹)	Feed rate (mm/min)	Depth of cut ap (mm)	Depth of cut ae (mm)
0.2	0.1	30000	100	0.01	0.01	30000	100	0.01	0.01
0.4	0.2	30000	150	0.02	0.08	30000	150	0.02	0.08
0.6	0.3	30000	200	0.03	0.14	30000	200	0.03	0.14
0.8	0.4	30000	250	0.04	0.19	30000	250	0.04	0.19
1	0.5	30000	300	0.05	0.25	30000	300	0.05	0.25
1.5	0.75	30000	300	0.075	0.275	30000	300	0.075	0.275
2	1	30000	300	0.1	0.3	30000	300	0.1	0.3
3	1.5	27500	275	0.125	0.33	27500	275	0.125	0.33
4	2	24000	240	0.15	0.35	24000	240	0.15	0.35
5	2.5	22000	220	0.175	0.37	22000	220	0.175	0.37
6	3	20000	200	0.2	0.4	20000	200	0.2	0.4

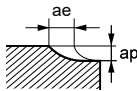
Depth of cut 

Work material		X							
		Silicon carbide Silicon nitride				Quartz glass			
Dia. DC (mm)	RE (mm)	Revolution (min ⁻¹)	Feed rate (mm/min)	Depth of cut ap (mm)	Depth of cut ae (mm)	Revolution (min ⁻¹)	Feed rate (mm/min)	Depth of cut ap (mm)	Depth of cut ae (mm)
0.2	0.1	30000	50	0.005	0.005	30000	150	0.015	0.015
0.4	0.2	30000	75	0.01	0.04	30000	225	0.03	0.12
0.6	0.3	30000	100	0.015	0.07	30000	300	0.045	0.21
0.8	0.4	30000	125	0.02	0.095	30000	375	0.06	0.285
1	0.5	30000	150	0.025	0.125	30000	450	0.075	0.375
1.5	0.75	30000	150	0.038	0.138	30000	450	0.113	0.413
2	1	30000	150	0.05	0.15	30000	450	0.15	0.45
3	1.5	27500	138	0.063	0.165	27500	413	0.188	0.495
4	2	24000	120	0.075	0.175	24000	360	0.225	0.525
5	2.5	22000	110	0.088	0.185	22000	330	0.263	0.555
6	3	20000	100	0.1	0.2	20000	300	0.3	0.6

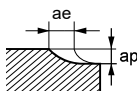
Depth of cut 

- Note 1) The carbide material in the cutting conditions table above is based on CIS standard VM-40(90HRA).
- Note 2) Air blow or dry processing is recommended for milling carbide material. Note: Using coolant or oil mist may decrease tool longevity.
- Note 3) The use of a water soluble cutting oil is recommended with the processing of hard brittle materials other than the carbide mentioned in the above table. Be sure to remove any chip discharge that adheres to the tool.
- Note 4) Cutting conditions may need adjusting depending on the type of material.
- Note 5) If the rigidity of the machine or work clamping is low, or chattering or noise is generated, reduce the feed and speed proportionately.
- Note 6) Implementation of special countermeasures is recommended since fine chip discharge may penetrate the machine tool mechanism.

DC2XLB

Ball nose, Short cut length, Long neck, For hard brittle materials, 2 flute



CARBIDE

Cemented Carbide	Alumina Zirconia	Silicon Carbide Silicon Nitride	Quartz Glass
○	○	○	○

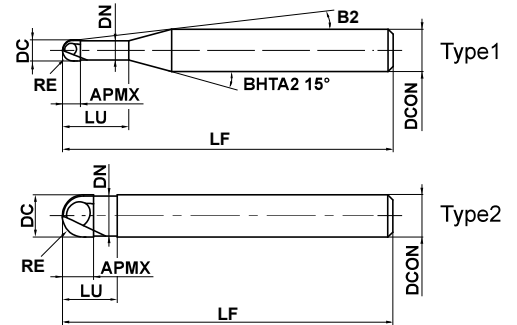

	$0.1 \leq RE \leq 3$				
	± 0.01				
	$4 \leq DCON \leq 6$				
	$\begin{matrix} 0 \\ -0.008 \end{matrix}$				

● DC long neck ball nose end mill for machining carbide and other hard brittle materials.

(mm)

Order Number	RE	DC	APMX	LU	DN	LF	DCON	B2	Flutes	Stock	Type
DC2XLBR0010N005	0.1	0.2	0.12	0.5	0.18	50	4	11.5°	2	★	1
DC2XLBR0020N010	0.2	0.4	0.24	1	0.36	50	4	11°	2	●	1
DC2XLBR0030N015	0.3	0.6	0.36	1.5	0.56	50	4	10.4°	2	★	1
DC2XLBR0040N020	0.4	0.8	0.48	2	0.76	50	4	9.9°	2	★	1
DC2XLBR0050N025	0.5	1	0.6	2.5	0.96	50	4	9.2°	2	●	1
DC2XLBR0050N050	0.5	1	0.6	5	0.96	50	4	7.3°	2	★	1
DC2XLBR0075N038	0.75	1.5	0.9	3.8	1.44	50	4	7.8°	2	★	1
DC2XLBR0100N060	1	2	1.2	6	1.94	50	4	5.8°	2	●	1
DC2XLBR0100N100	1	2	1.2	10	1.94	50	4	4.2°	2	★	1
DC2XLBR0150N080	1.5	3	1.8	8	2.9	60	6	6.3°	2	★	1
DC2XLBR0200N100	2	4	2.4	10	3.9	60	6	4.5°	2	★	1
DC2XLBR0250N100	2.5	5	3	10	4.9	60	6	2.9°	2	★	1
DC2XLBR0300N100	3	6	3.6	10	5.85	60	6	—	2	★	2

● : Inventory maintained. ★ : Inventory maintained in Japan.

SOLID END MILLS

SQUARE

BALL

RADIUS

TAPER

BARREL

ROUGHING

RECOMMENDED CUTTING CONDITIONS

Work material			X							
			Cemented Carbide				Alumina Zirconia			
Dia. DC (mm)	RE (mm)	Neck length LU (mm)	Revolution (min ⁻¹)	Feed rate (mm/min)	Depth of cut ap (mm)	Depth of cut ae (mm)	Revolution (min ⁻¹)	Feed rate (mm/min)	Depth of cut ap (mm)	Depth of cut ae (mm)
0.2	0.1	0.5	30000	30	0.005	0.01	30000	30	0.005	0.01
0.4	0.2	1	30000	100	0.015	0.08	30000	100	0.015	0.08
0.6	0.3	1.5	30000	200	0.03	0.14	30000	200	0.03	0.14
0.8	0.4	2	30000	250	0.04	0.19	30000	250	0.04	0.19
1	0.5	2.5	30000	300	0.05	0.25	30000	300	0.05	0.25
1	0.5	5	30000	300	0.05	0.25	30000	300	0.05	0.25
1.5	0.75	3.8	30000	300	0.075	0.275	30000	300	0.075	0.275
2	1	6	30000	300	0.1	0.3	30000	300	0.1	0.3
2	1	10	30000	300	0.1	0.3	30000	300	0.1	0.3
3	1.5	8	27500	275	0.125	0.33	27500	275	0.125	0.33
4	2	10	24000	240	0.15	0.35	24000	240	0.15	0.35
5	2.5	10	22000	220	0.175	0.37	22000	220	0.175	0.37
6	3	10	20000	200	0.2	0.4	20000	200	0.2	0.4

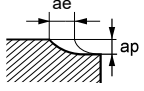

Work material			X							
			Silicon carbide Silicon nitride				Quartz glass			
Dia. DC (mm)	RE (mm)	Neck length LU (mm)	Revolution (min ⁻¹)	Feed rate (mm/min)	Depth of cut ap (mm)	Depth of cut ae (mm)	Revolution (min ⁻¹)	Feed rate (mm/min)	Depth of cut ap (mm)	Depth of cut ae (mm)
0.2	0.1	0.5	30000	15	0.003	0.005	30000	45	0.008	0.015
0.4	0.2	1	30000	50	0.008	0.04	30000	150	0.023	0.12
0.6	0.3	1.5	30000	100	0.015	0.07	30000	300	0.045	0.21
0.8	0.4	2	30000	125	0.02	0.095	30000	375	0.06	0.285
1	0.5	2.5	30000	150	0.025	0.125	30000	450	0.075	0.375
1	0.5	5	30000	150	0.025	0.125	30000	450	0.075	0.375
1.5	0.75	3.8	30000	150	0.038	0.138	30000	450	0.113	0.413
2	1	6	30000	150	0.05	0.15	30000	450	0.15	0.45
2	1	10	30000	150	0.05	0.15	30000	450	0.15	0.45
3	1.5	8	27500	138	0.063	0.165	27500	413	0.188	0.495
4	2	10	24000	120	0.075	0.175	24000	360	0.225	0.525
5	2.5	10	22000	110	0.088	0.185	22000	330	0.263	0.555
6	3	10	20000	100	0.1	0.2	20000	300	0.3	0.6

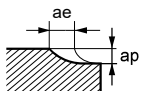

- Note 1) The carbide material in the cutting conditions table above is based on CIS standard VM-40(90HRA).
- Note 2) Air blow or dry processing is recommended for milling carbide material. Note: Using coolant or oil mist may decrease tool longevity.
- Note 3) The use of a water soluble cutting oil is recommended with the processing of hard brittle materials other than the carbide mentioned in the above table. Be sure to remove any chip discharge that adheres to the tool.
- Note 4) Cutting conditions may need adjusting depending on the type of material.
- Note 5) If the rigidity of the machine or work clamping is low, or chattering or noise is generated, reduce the feed and speed proportionately.
- Note 6) Implementation of special countermeasures is recommended since fine chip discharge may penetrate the machine tool mechanism.

VA2SS

End mill, Short cut length, 2 flute



HSS

Carbon Steel, Alloy Steel, Cast Iron (<30HRC)	Tool Steel, Pre-Hardened Steel, Hardened Steel (≤45HRC)	Hardened Steel (≤55HRC)	Hardened Steel (>55HRC)	Austenitic Stainless Steel	Titanium Alloy, Heat Resistant Alloy	Copper Alloy	Aluminium Alloy
○	○			○	○		

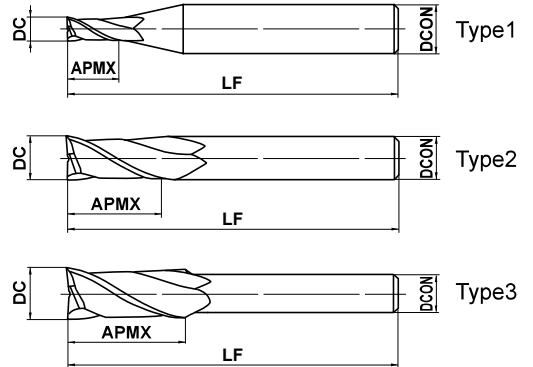

$3 \leq DC \leq 20$				
0				
- 0.030				

● 2 flute end mill with high grade HSS substrate and Violet coating for general use.

(mm)

Order Number	DC	APMX	LF	DCON	Flutes	Stock	Type
VA2SSD0300	3	8	50	6	2	●	1
VA2SSD0400	4	8	60	8	2	●	1
VA2SSD0500	5	10	60	8	2	●	1
VA2SSD0600	6	12	60	8	2	●	1
VA2SSD0700	7	15	65	10	2	●	1
VA2SSD0800	8	15	65	10	2	●	1
VA2SSD0900	9	20	75	10	2	●	1
VA2SSD1000	10	20	75	12	2	●	1
VA2SSD1100	11	22	85	12	2	★	1
VA2SSD1200	12	22	85	12	2	●	2
VA2SSD1400	14	26	95	16	2	●	1
VA2SSD1600	16	32	100	16	2	●	2
VA2SSD2000	20	38	120	20	2	★	2

● : Inventory maintained. ★ : Inventory maintained in Japan.

SOLID END MILLS

SQUARE

BALL

RADIUS

TAPER

BARREL

ROUGHING

VIOLET END MILLS

VA2MS

End mill, Medium cut length, 2 flute



DC < 3 DC > 3

Carbon Steel, Alloy Steel, Cast Iron (<30HRC)	Tool Steel, Pre-Hardened Steel, Hardened Steel (≤45HRC)	Hardened Steel (≤55HRC)	Hardened Steel (>55HRC)	Austenitic Stainless Steel	Titanium Alloy, Heat Resistant Alloy	Copper Alloy	Aluminium Alloy
○	○			○	○		

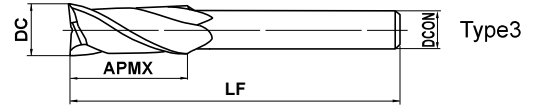
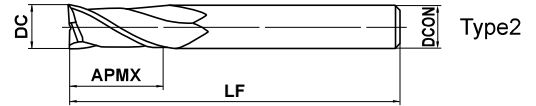
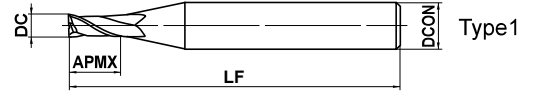

DC ≤ 20	DC > 20			
0	0			
- 0.030	- 0.040			

● 2 flute end mill with high grade HSS substrate and Violet coating for general use.

(mm)

Order Number	DC	APMX	LF	DCON	Flutes	Stock	Type
VA2MSD0300	3	10	50	6	2	●	1
VA2MSD0400	4	12	60	8	2	●	1
VA2MSD0500	5	15	60	8	2	●	1
VA2MSD0600	6	15	60	8	2	●	1
VA2MSD0700	7	20	65	10	2	●	1
VA2MSD0800	8	20	65	10	2	●	1
VA2MSD0900	9	25	75	10	2	●	1
VA2MSD1000	10	25	75	10	2	●	2
VA2MSD1100	11	30	85	12	2	●	1
VA2MSD1200	12	30	85	12	2	●	2
VA2MSD1300	13	35	90	12	2	●	3
VA2MSD1400	14	35	95	16	2	●	1
VA2MSD1500	15	40	100	16	2	●	1
VA2MSD1600	16	40	100	16	2	●	2
VA2MSD1700	17	40	100	16	2	★	3
VA2MSD1800	18	40	100	16	2	★	3
VA2MSD2000	20	45	120	20	2	★	2
VA2MSD2200	22	45	120	20	2	★	3

SOLID END MILLS

SQUARE

BALL

RADIUS

TAPER

BARREL

ROUGHING

VA2SS

End mill, Short cut length, 2 flute

VA2MS

End mill, Medium cut length, 2 flute

HSS

RECOMMENDED CUTTING CONDITIONS

Side milling

Work material	P						P	M
	Structural steel, Cast iron, Carbon steel Ck45, GG25, Cf53		Carbon steel, Alloy steel (20–30HRC) Ck55		Alloy steel, Tool steel, Pre-hardened steel (30–35HRC) X40CrMoV51, X210Cr12		Austenitic stainless steel, Alloy steel, Tool steel (35–40HRC) X5CrNi1810, X5CrNiMo17-12-2	
Dia. DC (mm)	Revolution (min ⁻¹)	Feed rate (mm/min)	Revolution (min ⁻¹)	Feed rate (mm/min)	Revolution (min ⁻¹)	Feed rate (mm/min)	Revolution (min ⁻¹)	Feed rate (mm/min)
3	5400	170	4000	125	2700	85	2200	65
4	4300	200	3200	150	2100	100	1800	75
5	3600	210	2700	160	1800	105	1500	80
6	3200	220	2400	165	1600	110	1300	85
8	2400	240	1800	180	1200	120	1000	90
10	1900	260	1400	190	950	130	800	100
12	1600	240	1200	180	800	120	660	90
16	1200	210	900	160	600	105	500	80
20	950	180	720	135	480	90	400	70
25	760	150	570	115	380	75	320	60

Depth of cut

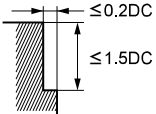

DC: Dia.

Slotting

Work material	P						P	M
	Structural steel, Cast iron, Carbon steel Ck45, GG25, Cf53		Carbon steel, Alloy steel (20–30HRC) Ck55		Alloy steel, Tool steel, Pre-hardened steel (30–35HRC) X40CrMoV51, X210Cr12		Austenitic stainless steel, Alloy steel, Tool steel (35–40HRC) X5CrNi1810, X5CrNiMo17-12-2	
Dia. DC (mm)	Revolution (min ⁻¹)	Feed rate (mm/min)	Revolution (min ⁻¹)	Feed rate (mm/min)	Revolution (min ⁻¹)	Feed rate (mm/min)	Revolution (min ⁻¹)	Feed rate (mm/min)
3	3700	110	3000	95	2100	65	1600	50
4	3200	140	2800	130	1800	75	1400	60
5	2900	160	2400	145	1500	80	1200	60
6	2600	170	2100	150	1300	85	1000	70
8	2000	190	1600	160	1000	90	800	70
10	1600	210	1300	180	800	100	640	80
12	1300	190	1100	165	660	90	530	70
16	1000	170	800	140	500	80	400	65
20	720	130	640	120	400	70	320	55
25	570	110	450	90	320	60	230	40

Depth of cut

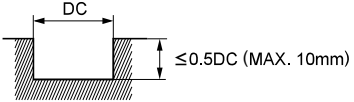

DC: Dia.

Note 1) Supply cutting fluid sufficiently during slotting. When dry cut, slotting decrease the revolution and feed rate by 20–30% proportionately.

Note 2) When drilling, please reduce the feed rate by 65%.

Note 3) If the rigidity of the machine or the work materials installation is very low, or chattering and noise are generated, reduce the revolution and feed rate proportionately.

SOLID END MILLS

SQUARE

BALL

RADIUS

TAPER

BARREL

ROUGHING

VIOLET END MILLS

VA4MC

End mill, Medium cut length, 4 flute



Carbon Steel, Alloy Steel, Cast Iron (<30HRC)	Tool Steel, Pre-Hardened Steel, Hardened Steel (≤45HRC)	Hardened Steel (≤55HRC)	Hardened Steel (>55HRC)	Austenitic Stainless Steel	Titanium Alloy, Heat Resistant Alloy	Copper Alloy	Aluminium Alloy
○	○			○	○		

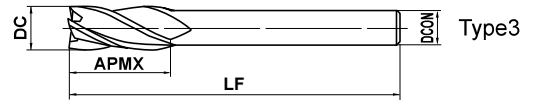
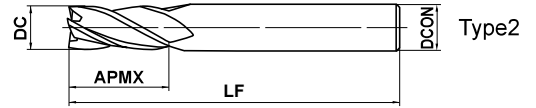
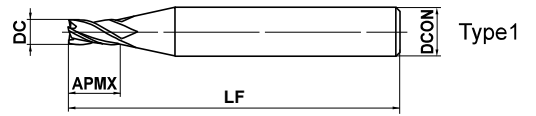

DC ≤ 20	DC > 20			
0 + 0.030	0 + 0.040			

● 4 flute end mill with high grade HSS substrate and Violet coating for general use.

(mm)

Order Number	DC	APMX	LF	DCON	Flutes	Stock	Type
VA4MCD0300	3	10	50	6	4	●	1
VA4MCD0400	4	12	60	8	4	●	1
VA4MCD0500	5	15	60	8	4	●	1
VA4MCD0600	6	15	60	8	4	●	1
VA4MCD0700	7	20	65	10	4	★	1
VA4MCD0800	8	20	65	10	4	●	1
VA4MCD0900	9	25	75	10	4	★	1
VA4MCD1000	10	25	75	10	4	●	2
VA4MCD1100	11	30	85	12	4	★	1
VA4MCD1200	12	30	85	12	4	●	2
VA4MCD1300	13	35	90	12	4	★	3
VA4MCD1400	14	35	95	16	4	●	1
VA4MCD1500	15	40	100	16	4	●	1
VA4MCD1600	16	40	100	16	4	●	2
VA4MCD1700	17	40	100	16	4	★	3
VA4MCD1800	18	40	100	16	4	●	3
VA4MCD2000	20	45	115	20	4	●	2
VA4MCD2200	22	45	115	20	4	★	3
VA4MCD2500	25	50	120	25	4	●	2

● : Inventory maintained. ★ : Inventory maintained in Japan.

SOLID END MILLS

HSS

—

SQUARE

BALL

RADIUS

TAPER

BARREL

ROUGHING

VA4MC

End mill, Medium cut length, 4 flute

HSS

RECOMMENDED CUTTING CONDITIONS

■ Side milling

Work material	P						P	M
	Structural steel, Cast iron, Carbon steel Ck45, GG25, Cf53		Carbon steel, Alloy steel (20–30HRC) Ck55		Alloy steel, Tool steel, Pre-hardened steel (30–35HRC) X40CrMoV51, X210Cr12		Austenitic stainless steel, Alloy steel, Tool steel (35–40HRC) X5CrNi1810, X5CrNiMo17-12-2	
Dia. DC (mm)	Revolution (min ⁻¹)	Feed rate (mm/min)	Revolution (min ⁻¹)	Feed rate (mm/min)	Revolution (min ⁻¹)	Feed rate (mm/min)	Revolution (min ⁻¹)	Feed rate (mm/min)
3	5400	270	4000	200	2700	140	2200	100
4	4300	320	3200	240	2100	160	1800	120
5	3600	340	2700	250	1800	170	1500	130
6	3200	350	2400	260	1600	180	1300	140
8	2400	380	1800	290	1200	190	1000	145
10	1900	420	1400	300	950	210	800	160
12	1600	380	1200	290	800	190	660	145
16	1200	340	900	260	600	170	500	130
20	950	290	720	220	480	140	400	110
25	760	240	570	180	380	120	320	100

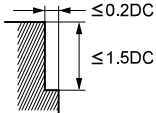
Depth of cut		DC: Dia.
--------------	--	----------

Note 1) If the rigidity of the machine or the work materials installation is very low, or chattering and noise are generated, reduce the revolution and feed rate proportionately.

SOLID END MILLS

SQUARE

BALL

RADIUS

TAPER

BARREL

ROUGHING

VIOLET END MILLS

VASFPR

Roughing type, Short cut length, Fine pitch form, 4-5 flutes

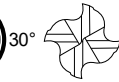

DC ≤ 24 25 < DC ≤ 32

Carbon Steel, Alloy Steel, Cast Iron (<30HRC)	Tool Steel, Pre-Hardened Steel, Hardened Steel (≤45HRC)	Hardened Steel (≤55HRC)	Hardened Steel (>55HRC)	Austenitic Stainless Steel	Titanium Alloy, Heat Resistant Alloy	Copper Alloy	Aluminium Alloy
○	○			○	○		

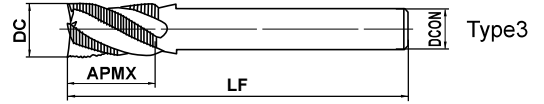
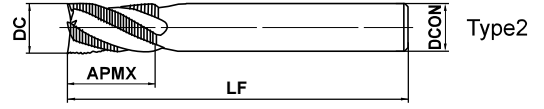
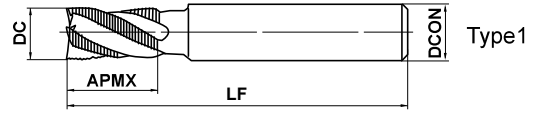

● Roughing end mill with high grade HSS substrate and Violet coating for general use.

(mm)

Order Number	DC	APMX	LF	DCON	Flutes	Stock	Type
VASFPRD0500	5	10	80	6	4	●	1
VASFPRD0600	6	12	80	6	4	●	2
VASFPRD0700	7	17	80	8	4	●	1
VASFPRD0800	8	17	85	8	4	●	2
VASFPRD0900	9	22	100	10	4	●	1
VASFPRD1000	10	22	100	10	4	●	2
VASFPRD1200	12	27	110	12	4	●	2
VASFPRD1400	14	27	110	12	4	●	3
VASFPRD1500	15	27	125	16	4	★	1
VASFPRD1600	16	33	125	16	4	●	2
VASFPRD1800	18	33	125	16	4	●	3
VASFPRD2000	20	38	145	20	4	●	2
VASFPRD2200	22	38	145	20	4	●	3
VASFPRD2500	25	43	150	25	5	●	2
VASFPRD3000	30	48	165	25	5	★	3

● : Inventory maintained. ★ : Inventory maintained in Japan.

SOLID END MILLS

SQUARE

BALL

RADIUS

TAPER

BARREL

ROUGHING

VASFPR

Roughing type, Short cut length, Fine pitch form, 4-5 flutes

HSS

RECOMMENDED CUTTING CONDITIONS

Side milling

Work material	P						P	M
	Structural steel, Cast iron, Carbon steel Ck45, GG25, Cf53		Carbon steel, Alloy steel (20–30HRC) Ck55		Alloy steel, Tool steel, Pre-hardened steel (30–35HRC) X40CrMoV51, X210Cr12		Austenitic stainless steel, Alloy steel, Tool steel (35–40HRC) X5CrNi1810, X5CrNiMo17-12-2	
Dia. DC (mm)	Revolution (min ⁻¹)	Feed rate (mm/min)	Revolution (min ⁻¹)	Feed rate (mm/min)	Revolution (min ⁻¹)	Feed rate (mm/min)	Revolution (min ⁻¹)	Feed rate (mm/min)
5	2800	140	2200	120	1500	80	1300	70
6	2600	180	2000	140	1400	90	1200	80
8	2200	230	1700	180	1200	130	990	100
10	1750	330	1350	250	950	160	800	130
12	1450	330	1100	260	800	180	660	140
16	1100	330	850	260	600	180	500	140
20	880	340	680	260	480	180	400	140
25	700	330	540	250	380	170	320	140
30	580	300	450	230	320	170	270	140

Depth of cut

≤ 0.5DC
≤ 1.5DC

DC: Dia.

Slotting

Work material	P						P	M
	Structural steel, Cast iron, Carbon steel Ck45, GG25, Cf53		Carbon steel, Alloy steel (20–30HRC) Ck55		Alloy steel, Tool steel, Pre-hardened steel (30–35HRC) X40CrMoV51, X210Cr12		Austenitic stainless steel, Alloy steel, Tool steel (35–40HRC) X5CrNi1810, X5CrNiMo17-12-2	
Dia. DC (mm)	Revolution (min ⁻¹)	Feed rate (mm/min)	Revolution (min ⁻¹)	Feed rate (mm/min)	Revolution (min ⁻¹)	Feed rate (mm/min)	Revolution (min ⁻¹)	Feed rate (mm/min)
5	2100	100	1650	80	1150	50	960	35
6	2000	130	1550	100	1050	60	900	45
8	1600	160	1300	130	920	90	760	60
10	1300	220	1000	175	730	110	610	80
12	1050	230	850	190	610	130	500	85
16	800	230	640	190	460	130	380	85
20	640	230	510	180	370	130	300	85
25	510	200	410	160	290	110	240	80
30	420	190	320	140	210	90	180	75

Depth of cut

DC
≤ 1DC (MAX. 30mm)

DC: Dia.

Note 1) Supply cutting fluid sufficiently during cutting. For dry-cutting, decrease the revolution and feed rate proportionately by 20–50%.

Note 2) For smaller depths and widths of cut, the revolution may be increased by 10–20% and the feed rate by 10–40%.

Note 3) When drilling, reduce the feed rate by 65%.

Note 4) If the rigidity of the machine or the work materials installation is very low, or chattering and noise are generated, reduce the revolution and feed rate proportionately.

SOLID END MILLS

SQUARE

BALL

RADIUS

TAPER

BARREL

ROUGHING

VIOLET END MILLS

VAMFPR

Roughing type, Medium cut length, Fine pitch form, 4-6 flutes



30°



DC < 20 22 ≤ DC ≤ 28 DC ≥ 30

Carbon Steel, Alloy Steel, Cast Iron (<30HRC)	Tool Steel, Pre-Hardened Steel, Hardened Steel (≤45HRC)	Hardened Steel (≤55HRC)	Hardened Steel (>55HRC)	Austenitic Stainless Steel	Titanium Alloy, Heat Resistant Alloy	Copper Alloy	Aluminium Alloy
○	○			○	○		



● Roughing end mill with high grade HSS substrate and Violet coating for general use.

(mm)

Order Number	DC	APMX	LF	DCON	Flutes	Stock	Type
VAMFPRD0500	5	15	80	6	4	●	1
VAMFPRD0600	6	17	80	6	4	●	2
VAMFPRD0700	7	22	80	8	4	●	1
VAMFPRD0800	8	28	85	8	4	●	2
VAMFPRD0900	9	28	95	10	4	★	1
VAMFPRD1000	10	34	100	10	4	●	2
VAMFPRD1200	12	40	110	12	4	★	2
VAMFPRD1400	14	40	110	12	4	●	3
VAMFPRD1500	15	40	120	16	4	●	1
VAMFPRD1600	16	48	125	16	4	●	2
VAMFPRD1800	18	48	125	16	4	●	3
VAMFPRD2000	20	57	145	20	4	●	2
VAMFPRD2200	22	57	145	20	5	★	3
VAMFPRD2500	25	68	150	25	5	★	2
VAMFPRD3000	30	68	165	25	6	★	3

● : Inventory maintained. ★ : Inventory maintained in Japan.

VAMFPR

Roughing type, Medium cut length, Fine pitch form, 4-6 flutes

HSS

RECOMMENDED CUTTING CONDITIONS

■ Side milling

Work material	P						P	M
	Structural steel, Cast iron, Carbon steel Ck45, GG25, Cf53		Carbon steel, Alloy steel (20–30HRC) Ck55		Alloy steel, Tool steel, Pre-hardened steel (30–35HRC) X40CrMoV51, X210Cr12		Austenitic stainless steel, Alloy steel, Tool steel (35–40HRC) X5CrNi1810, X5CrNiMo17-12-2	
Dia. DC (mm)	Revolution (min ⁻¹)	Feed rate (mm/min)	Revolution (min ⁻¹)	Feed rate (mm/min)	Revolution (min ⁻¹)	Feed rate (mm/min)	Revolution (min ⁻¹)	Feed rate (mm/min)
5	2600	90	2000	70	1400	50	1200	40
6	2500	100	1900	90	1300	50	1100	50
8	2000	170	1600	130	1100	90	930	80
10	1650	220	1300	170	900	100	750	90
12	1400	260	1000	210	750	140	620	120
16	1000	290	800	230	560	160	470	130
20	830	300	640	230	450	160	380	130
25	660	290	510	220	360	160	300	130
30	550	270	420	210	300	140	250	130

Depth of cut	
	DC: Dia.

Note 1) Supply cutting fluid sufficiently during cutting. For dry-cutting, decrease the revolution and feed rate proportionately by 20–50%.

Note 2) When the diameter exceeds 30 and the metal removal is less than the quantity shown in the table, the revolution and feed rate may be increased proportionately by 10–40%.

Note 3) If the rigidity of the machine or the work materials installation is very low, or chattering and noise are generated, reduce the revolution and feed rate proportionately.

SOLID END MILLS

SQUARE

BALL

RADIUS

TAPER

BARREL

ROUGHING

VIOLET END MILLS

VAMR

Roughing type, Medium cut length, Medium pitch form, 4/5 flutes



30°



DC ≤ 15 16 ≤ DC ≤ 26 28 ≤ DC ≤ 32

Carbon Steel, Alloy Steel, Cast Iron (<30HRC)	Tool Steel, Pre-Hardened Steel, Hardened Steel (≤45HRC)	Hardened Steel (≤55HRC)	Hardened Steel (>55HRC)	Austenitic Stainless Steel	Titanium Alloy, Heat Resistant Alloy	Copper Alloy	Aluminium Alloy
◎	○			◎	○		

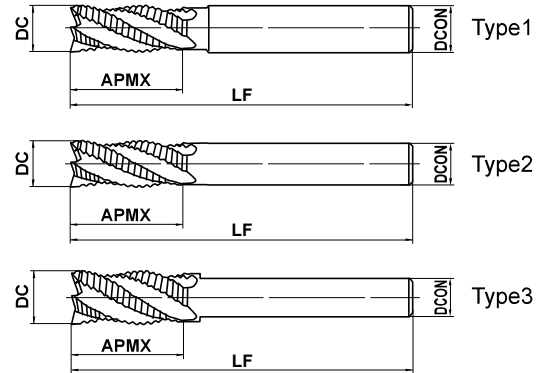

● Roughing end mill with high grade HSS substrate and Violet coating for general use.

(mm)

Order Number	DC	APMX	LF	DCON	Flutes	Stock	Type
VAMRD0500	5	15	60	6	4	●	1
VAMRD0600	6	15	60	6	4	●	2
VAMRD0700	7	20	70	8	4	●	1
VAMRD0800	8	20	70	8	4	●	2
VAMRD0900	9	25	80	10	4	●	1
VAMRD1000	10	25	80	10	4	●	2
VAMRD1100	11	30	110	12	4	●	1
VAMRD1200	12	30	110	12	4	●	2
VAMRD1300	13	35	115	12	4	●	3
VAMRD1400	14	35	135	16	4	●	1
VAMRD1500	15	40	140	16	4	★	1
VAMRD1600	16	40	140	16	4	●	2
VAMRD1700	17	40	140	16	4	●	3
VAMRD1800	18	40	140	16	4	★	3
VAMRD1900	19	45	145	20	4	★	1
VAMRD2000	20	45	145	20	4	●	2
VAMRD2200	22	45	145	20	4	★	3
VAMRD2500	25	50	150	25	4	●	2
VAMRD3000	30	55	165	25	5	★	3
VAMRD3200	32	60	175	32	5	★	2

● : Inventory maintained. ★ : Inventory maintained in Japan.

RECOMMENDED CUTTING CONDITIONS

■ Side milling

Work material	P						P	M
	Structural steel, Cast iron, Carbon steel Ck45, GG25, Cf53		Carbon steel, Alloy steel (20–30HRC) Ck55		Alloy steel, Tool steel, Pre-hardened steel (30–35HRC) X40CrMoV51, X210Cr12		Austenitic stainless steel, Alloy steel, Tool steel (35–40HRC) X5CrNi1810, X5CrNiMo17-12-2	
Dia. DC (mm)	Revolution (min ⁻¹)	Feed rate (mm/min)	Revolution (min ⁻¹)	Feed rate (mm/min)	Revolution (min ⁻¹)	Feed rate (mm/min)	Revolution (min ⁻¹)	Feed rate (mm/min)
5	2400	120	1800	90	1200	60	1000	50
6	2200	155	1700	120	1100	70	930	65
8	1800	200	1400	140	950	100	780	85
10	1500	250	1100	200	810	125	680	100
12	1250	270	960	220	680	160	560	120
16	930	270	720	220	510	160	430	120
20	750	290	580	220	410	160	340	120
25	600	270	460	210	320	140	270	120
30	490	250	380	200	270	140	230	120

Depth of cut

$\leq 0.5DC$
 $\leq 1.5DC$

DC: Dia.

■ Slotting

Work material	P						P	M
	Structural steel, Cast iron, Carbon steel Ck45, GG25, Cf53		Carbon steel, Alloy steel (20–30HRC) Ck55		Alloy steel, Tool steel, Pre-hardened steel (30–35HRC) X40CrMoV51, X210Cr12		Austenitic stainless steel, Alloy steel, Tool steel (35–40HRC) X5CrNi1810, X5CrNiMo17-12-2	
Dia. DC (mm)	Revolution (min ⁻¹)	Feed rate (mm/min)	Revolution (min ⁻¹)	Feed rate (mm/min)	Revolution (min ⁻¹)	Feed rate (mm/min)	Revolution (min ⁻¹)	Feed rate (mm/min)
5	1800	85	1350	60	920	40	740	25
6	1700	110	1300	85	830	45	700	35
8	1300	140	1050	100	730	70	600	50
10	1100	170	810	140	620	85	520	60
12	900	190	740	160	520	115	420	75
16	680	190	540	160	390	115	330	75
20	550	195	440	150	320	115	260	75
25	440	170	350	135	240	90	200	70
30	350	160	270	120	180	75	155	65

Depth of cut

$\leq 1DC$ (MAX. 30mm)

DC: Dia.

- Note 1) Supply cutting fluid sufficiently during cutting. For dry-cutting, decrease the revolution and feed rate proportionately by 20–50%.
- Note 2) When the diameter exceeds 30 and the metal removal is less than the quantity shown in the table, the revolution and feed rate may be increased proportionately by 10–40%.
- Note 3) If the rigidity of the machine or the work materials installation is very low, or chattering and noise are generated, reduce the revolution and feed rate proportionately.

HOW TO READ THE STANDARD OF INDEXABLE HEAD END MILLS

● How this section page is organised

① Organised according to cutting mode for milling. (Refer to the END MILL LIST)

CUTTING EDGE GEOMETRY
PHOTO OF PRODUCT
ITEM DESCRIPTION
PRODUCT TITLE
PRODUCT BLOCK

INDEXABLE HEAD END MILLS
iMX-S3HV
 Square head, Irregular helix, 3 flute

PRODUCT INFORMATION ICONS

GEOMETRY

PRODUCT FEATURES

3-flute end mills suitable for side milling, slotting and plunging.
 Irregular helix controls vibration and achieves stable machining.

Order Number	DC	APMX	LH	DCON	Flutes	Grade	Type
IMX10S3HV10008	10	8	16	9.7	3	●	1
IMX12S3HV12009	12	9.6	19	11.7	3	●	1
IMX16S3HV16012	16	12.8	24	15.5	3	●	1
IMX20S3HV20016	20	16	30	19.5	3	●	1
IMX25S3HV25020	25	20	37.5	24.5	3	●	1

Note 1) The fastening size of the holder and head should be the same. (refer to Page J002)

LEGEND FOR STOCK STATUS MARK
 is shown on the left hand page of each double-page spread.

PRODUCT STANDARDS
 indicates order numbers, dimensions, and stock status.

J008 ● : Inventory maintained.

IDENTIFICATION

iMX END MILL SERIES

HEAD

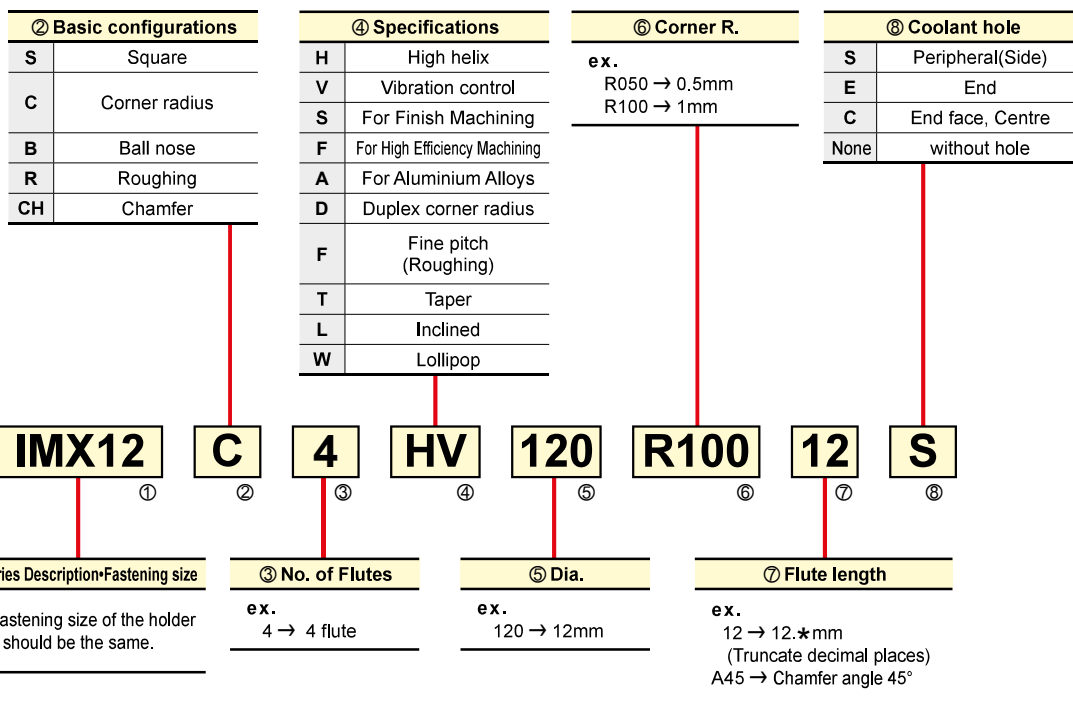

HOLDER

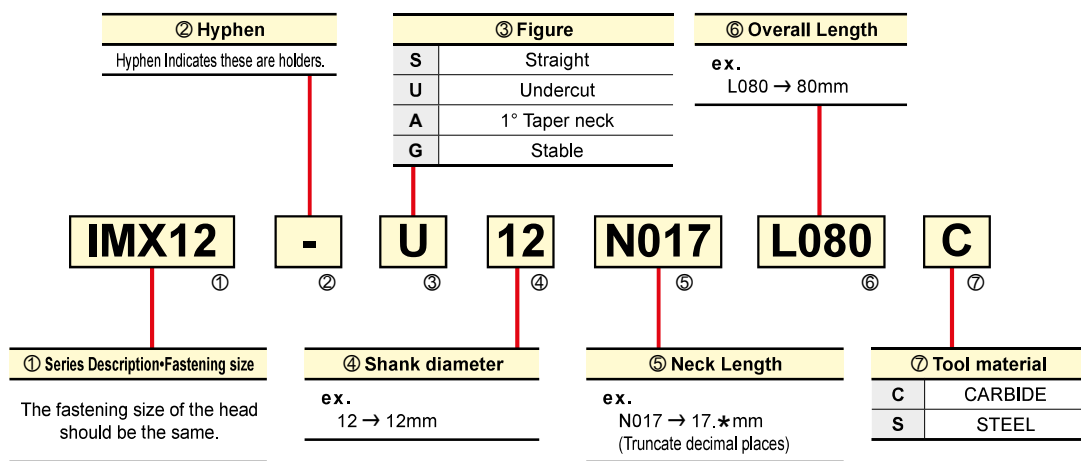

RUN-OUT ACCURACY AND HEAD EXCHANGE ACCURACY

External diameter DC	Run-out accuracy for the peripheral cutting edge *	Head exchange accuracy (Axial)
<ø25	0.015	±0.05
≥ø25	0.020	

* Use the carbide holder. (Except iMX-RC4F-C, iMX-R4F roughing head)

INDEXABLE HEAD END MILLS

SYMBOL DESCRIPTIONS

Tool Material



Ultra micro grain carbide
Ultra micro grain carbide is used as the substrate material.

Angle, Coolant hole, Sharp corner edge and Gash land



Helix angle
Indicates the helix angle of the end mill.



End cutting edge with coolant hole



Peripheral cutting edge with coolant hole



Gash land
Indicates the end mill cutting edge has a gash land.

Tolerances



Outside diameter tolerance
Indicates diameter tolerance of end mill.



R tolerance
Indicates the radial tolerance of a ball nose end mill.



R tolerance
Indicates the radial tolerance of an end mill with a corner radius.



Tolerance of point diameter
Indicates the tolerance of the point diameter.

Correction factor by overhang length (Shoulder Milling)

Use by multiplying the recommended cutting condition by the correction factor of the overhang length.
Refer to each recommended condition for the long cutting edge and offset type.













Work material	P		N		P				M		S	
	Carbon steel, Alloy steel, Mild Steel, Copper, Copper alloys				Pre-hardened steel, Carbon steel, Alloy steel, Alloy tool steel				Austenitic stainless steel, Ferritic and Martensitic stainless steels, Titanium alloy			
L/D	Cutting Speed (m/min)	Main Spindle Revolution (min ⁻¹)	Feed per Tooth (mm/t)	Cutting Width ae (mm)	Cutting Speed (m/min)	Main Spindle Revolution (min ⁻¹)	Feed per Tooth (mm/t)	Cutting Width ae (mm)	Cutting Speed (m/min)	Main Spindle Revolution (min ⁻¹)	Feed per Tooth (mm/t)	Cutting Width ae (mm)
2	100%	100%	100%	100%	100%	100%	100%	100%	100%	100%	100%	100%
3	100%	100%	100%	100%	100%	100%	100%	100%	100%	100%	100%	100%
4	80%	80%	90%	70%	80%	80%	90%	70%	80%	80%	90%	70%
5	60%	60%	80%	40%	60%	60%	80%	40%	60%	60%	80%	40%
6	50%	50%	70%	30%	50%	50%	70%	30%	50%	50%	70%	30%
7	40%	40%	70%	20%	40%	40%	70%	20%	30%	30%	60%	20%
8	40%	40%	60%	10%	40%	40%	60%	10%	30%	30%	50%	10%
9	30%	30%	60%	10%	30%	30%	60%	10%	20%	20%	50%	10%

Work material	M		S		S			
	Precipitation hardening stainless steel, Cobalt chromium alloy				Heat resistant alloys			
L/D	Cutting Speed (m/min)	Main Spindle Revolution (min ⁻¹)	Feed per Tooth (mm/t)	Cutting Width ae (mm)	Cutting Speed (m/min)	Main Spindle Revolution (min ⁻¹)	Feed per Tooth (mm/t)	Cutting Width ae (mm)
2	100%	100%	100%	100%	100%	100%	100%	100%
3	100%	100%	100%	100%	100%	100%	100%	100%
4	80%	80%	90%	70%	80%	80%	90%	70%
5	60%	60%	80%	40%	60%	60%	80%	40%
6	50%	50%	70%	30%	50%	50%	70%	30%
7	30%	30%	60%	20%	30%	30%	60%	20%
8	30%	30%	50%	10%	30%	30%	50%	10%
9	20%	20%	50%	10%	20%	20%	50%	10%

CLASSIFICATION











HEAD

(mm)

Type	Applications, Features	No. of Flutes	Product Code	Shape	Size Range	Coolant	Long cutting edge	Work Material						Page
								P	H	M	S	N		
								Carbon Steel	Tool steel	55HRC	55HRC-	Stainless steel	Titanium Alloy Heat Resistant Alloy	
SQUARE														
For Difficult-to-cut Materials		3	iMX-S3HV	Square head, 3 flute, Irregular helix 	φ10—φ25			○	○		○	○	J008	
		4	iMX-S4HV	Square head, 4 flute, Irregular helix 	φ10—φ32						○	○	J012	
				Square head, 4 flute, Irregular helix, Long cutting edge type 	φ16, φ20	●					○		J012	
		4	iMX-S4HV-S	Square head, 4 flute, Irregular helix, with coolant hole 	φ10—φ25	●	○			○	○		J013	
For Aluminium Alloys		3	iMX-S3A	Square head, 3 flute, For aluminium alloy 	φ10—φ28							○	J019	
RADIUS														
For Difficult-to-cut Materials		4	iMX-C4HV	Corner radius head, 4 flute, Irregular helix 	φ10—φ28			○	○		○	○	J038	
				Corner radius head, 4 flute, Irregular helix, Long cutting edge type 	φ16, φ20	●							J039	
		4	iMX-C4HV-S	Corner radius head, 4 flute, Irregular helix, with coolant hole 	φ10—φ25	●	○			○	○		J040	
		6	iMX-C6HV	Corner radius head, Multi-flute, Irregular helix 	φ10, φ12			○	○		○	○	J047	
		10	iMX-C10HV		φ16			○	○		○	○		
		12	iMX-C12HV		φ20, φ25			○	○					
For High Feed		4	iMX-C4FD-C	Duplex corner radius head with coolant hole, 4 flute, For high feed 	φ10—φ25	●	○	○	○		○	○	J049	
For High Efficiency Machining		4	iMX-C4FV	Corner radius head for high efficiency machining, 4 flute, Irregular helix 	φ10—φ25			○	○	○			J051	
For Aluminium Alloys		3	iMX-C3A	Corner radius head, 3 flute, For aluminium alloy 	φ10—φ28							○	J053	
For Blade		8	iMX-C8T-C	Corner radius, Taper head, Multi-flute, with coolant hole 	φ8	●					○	○	J056	
		10	iMX-C10T-C		φ10	●					○	○		
		12	iMX-C12T-C		φ15, φ19	●					○	○		
		15	iMX-C15T-C		φ15, φ19	●					○	○		





INDEXABLE HEAD END MILLS

(mm)

Type	Applications, Features	No. of Flutes	Product Code	Shape	Size Range	Coolant	Long cutting edge	Work Material						Page	
								P	H	M	S	N			
								Carbon Steel	Tool steel	55HRC	55HRC-	Stainless steel	Titanium Alloy Heat Resistant Alloy		Copper Alloy
ROUGHING															
	For Difficult-to-cut Materials	4	iMX-R4F	Roughing head, 4 flute 	φ10—φ25			◎	○			◎	◎	○	J022
	For Titanium Alloys	4	NEW iMX-RC4F-C	Roughing head, 4 flute, with coolant hole 	φ10—φ20	●		○				○	◎		J025
BALL															
	For Hardened Steel	2	iMX-B2S	Ball nose head, 2 flute, For hardened steel 	φ16, φ20							◎			J027
		4	NEW iMX-B4S	Ball nose head, 4 flute, For hardened steel 	φ16, φ20								◎		
	For High Efficiency Machining	3	iMX-B3FV	Ball nose head, For high efficiency machining, 3 flute, Irregular curve 	φ10—φ20			◎	◎						J029
	For Difficult-to-cut Materials	4	iMX-B4HV	Ball nose head, 4 flute, Irregular curve 	φ10—φ25			◎	○			◎	◎	○	J031
		4	iMX-B4HV-E	Ball nose head, 4 flute, Irregular curve, with coolant hole 	φ10—φ25	●		◎	○			◎	◎	○	J032
		6	iMX-B6HV	Ball nose head, 6 flute, Irregular curve 	φ10—φ25			◎	○			◎	◎		J034
LOLLIPOP															
	For Difficult-to-cut Materials	4	NEW iMX-B4WH-S	Lollipop head, 4 flute, with coolant hole 	φ12—φ20	●		◎	○			◎	◎	○	J036
CHAMFER															
	For Chamfer Materials	3	iMX-CH3L	Chamfer head, 3 flute 	φ10—φ20			◎	○	○		◎	◎		J058
		6	iMX-CH6V	Chamfer head, 6 flute 	φ12—φ20			◎	○	○			◎	◎	

CLASSIFICATION

HOLDER

	Type	Length	Taper Angle	Material	Page
Under cut		Medium	—	Carbide	J062
		Semi-long		Steel	J063
Straight		Long	—	Carbide	J062
		Medium		Steel	J063
Taper neck		Long	1°	Carbide	J062

Memo

A series of horizontal dashed lines for writing, spanning the width of the page.

INDEXABLE HEAD END MILLS

IMX-S3HV

Square head, Irregular helix, 3 flute

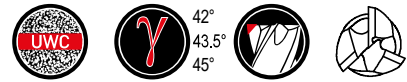

Carbon Steel, Alloy Steel, Cast Iron (<30HRC)	Tool Steel, Pre-Hardened Steel, Hardened Steel (≤45HRC)	Hardened Steel (≤55HRC)	Hardened Steel (>55HRC)	Austenitic Stainless Steel	Titanium Alloy, Heat Resistant Alloy	Copper Alloy	Aluminium Alloy
○	○			○	○	○	

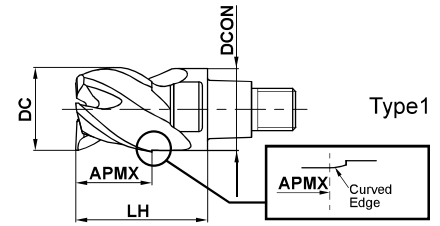

INDEXABLE HEAD END MILLS

SQUARE

BALL

RADIUS

TAPER

CHAMFER

ROUGHING

	DC ≤ 12	DC > 12			
	0 - 0.020	0 - 0.030			

- 3-flute end mills suitable for side milling, slotting and plunging.
- Irregular helix controls vibration and achieves stable machining.

(mm)

Order Number	DC	APMX	LH	DCON	Flutes	Grade	Type
						EP7020	
IMX10S3HV10008	10	8	16	9.7	3	●	1
IMX12S3HV12009	12	9.6	19	11.7	3	●	1
IMX16S3HV16012	16	12.8	24	15.5	3	●	1
IMX20S3HV20016	20	16	30	19.5	3	●	1
IMX25S3HV25020	25	20	37.5	24.5	3	●	1

Note 1) The fastening size of the holder and head should be the same. (refer to Page J002.)

● : Inventory maintained.

RECOMMENDED CUTTING CONDITIONS

Shoulder milling (L/D=3)

Other than the L/D = 3, use following recommended cutting conditions by multiplying the J003 page correction factor of the overhang length.

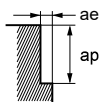
Work material	P						N						P						M						S										
	Carbon steel, Alloy steel, Mild Steel, Copper, Copper alloys												Pre-hardened steel, Carbon steel, Alloy steel, Alloy tool steel												Austenitic stainless steel, Ferritic and martensitic stainless steel, Titanium alloy										
Dia. DC (mm)	Cutting Speed (m/min)	Main Spindle Revolution (min ⁻¹)	Feed per Tooth (mm/t)	Table Feed per Min. (mm/min)	Depth of Cut ap (mm)	Cutting Width ae (mm)	Cutting Speed (m/min)	Main Spindle Revolution (min ⁻¹)	Feed per Tooth (mm/t)	Table Feed per Min. (mm/min)	Depth of Cut ap (mm)	Cutting Width ae (mm)	Cutting Speed (m/min)	Main Spindle Revolution (min ⁻¹)	Feed per Tooth (mm/t)	Table Feed per Min. (mm/min)	Depth of Cut ap (mm)	Cutting Width ae (mm)	Cutting Speed (m/min)	Main Spindle Revolution (min ⁻¹)	Feed per Tooth (mm/t)	Table Feed per Min. (mm/min)	Depth of Cut ap (mm)	Cutting Width ae (mm)											
10	150	4800	0.09	1300	8	2	120	3800	0.06	680	8	2	100	3200	0.075	720	8	2	100	3200	0.075	720	8	2											
12	150	4000	0.09	1100	9.6	2.4	120	3200	0.065	620	9.6	2.4	100	2700	0.08	650	9.6	2.4	100	2700	0.08	650	9.6	2.4											
16	150	3000	0.1	900	12.8	3.2	120	2400	0.075	540	12.8	3.2	100	2000	0.09	540	12.8	3.2	100	2000	0.09	540	12.8	3.2											
20	150	2400	0.1	720	16	4	120	1900	0.075	430	16	4	100	1600	0.09	430	16	4	100	1600	0.09	430	16	4											
25	150	1900	0.12	680	20	5	120	1500	0.075	340	20	5	100	1300	0.09	350	20	5	100	1300	0.09	350	20	5											
Depth of cut																																			

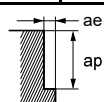
Work material	M						S						S											
	Precipitation hardening stainless steel, Cobalt chromium alloy												Heat resistant alloys											
Dia. DC (mm)	Cutting Speed (m/min)	Main Spindle Revolution (min ⁻¹)	Feed per Tooth (mm/t)	Table Feed per Min. (mm/min)	Depth of Cut ap (mm)	Cutting Width ae (mm)	Cutting Speed (m/min)	Main Spindle Revolution (min ⁻¹)	Feed per Tooth (mm/t)	Table Feed per Min. (mm/min)	Depth of Cut ap (mm)	Cutting Width ae (mm)	Cutting Speed (m/min)	Main Spindle Revolution (min ⁻¹)	Feed per Tooth (mm/t)	Table Feed per Min. (mm/min)	Depth of Cut ap (mm)	Cutting Width ae (mm)	Cutting Speed (m/min)	Main Spindle Revolution (min ⁻¹)	Feed per Tooth (mm/t)	Table Feed per Min. (mm/min)	Depth of Cut ap (mm)	Cutting Width ae (mm)
10	75	2400	0.06	430	8	2	40	1300	0.04	160	8	1	40	1300	0.04	160	8	1	40	1300	0.04	160	8	1
12	75	2000	0.065	390	9.6	2.4	40	1100	0.045	150	9.6	1.2	40	1100	0.045	150	9.6	1.2	40	1100	0.045	150	9.6	1.2
16	75	1500	0.075	340	12.8	3.2	40	800	0.05	120	12.8	1.6	40	800	0.05	120	12.8	1.6	40	800	0.05	120	12.8	1.6
20	75	1200	0.075	270	16	4	40	640	0.05	96	16	2	40	640	0.05	96	16	2	40	640	0.05	96	16	2
25	75	950	0.075	210	20	5	40	510	0.05	77	20	2.5	40	510	0.05	77	20	2.5	40	510	0.05	77	20	2.5
Depth of cut																								

Note 1) For stainless steel, titanium and heat resistant alloys, the use of water-soluble coolant is effective.

Note 2) If the depth of cut is shallow, the revolution and feed rate can be increased.

Note 3) The irregular helix flute end mill has a large effect on controlling vibration when compared to standard end mills.

However, if the rigidity of the machine or the workpiece installation is poor, vibration or abnormal sound can occur. In this case, please reduce the revolution and feed rate proportionately, or set a lower depth of cut.

INDEXABLE HEAD END MILLS

IMX-S3HV

Square head, Irregular helix, 3 flute

RECOMMENDED CUTTING CONDITIONS

■ Slot milling

Work material	P					N					P					M		S					
	Carbon steel, Alloy steel, Mild Steel, Copper, Copper alloys										Pre-hardened steel, Carbon steel, Alloy steel, Alloy tool steel										Austenitic stainless steel, Ferritic and martensitic stainless steel, Titanium alloy		
DC (mm)	Cutting speed (m/min)	Main Spindle Revolution (min ⁻¹)	Feed per Tooth (mm/t)	Table Feed per Min. (mm/min)	Depth of cut ap (mm)	Cutting speed (m/min)	Main Spindle Revolution (min ⁻¹)	Feed per Tooth (mm/t)	Table Feed per Min. (mm/min)	Depth of cut ap (mm)	Cutting speed (m/min)	Main Spindle Revolution (min ⁻¹)	Feed per Tooth (mm/t)	Table Feed per Min. (mm/min)	Depth of cut ap (mm)	Cutting speed (m/min)	Main Spindle Revolution (min ⁻¹)	Feed per Tooth (mm/t)	Table Feed per Min. (mm/min)	Depth of cut ap (mm)			
10	100	3200	0.04	380	5	80	2500	0.03	230	5	75	2400	0.03	200	5	75	2400	0.03	200	5			
12	100	2700	0.05	410	6	80	2100	0.04	250	6	75	2000	0.04	240	6	75	2000	0.04	240	6			
16	100	2000	0.07	420	8	80	1600	0.05	240	8	75	1500	0.06	270	8	75	1500	0.06	270	8			
20	100	1600	0.07	340	10	80	1300	0.05	200	10	75	1200	0.06	220	10	75	1200	0.06	220	10			
25	100	1300	0.08	310	12	80	1000	0.05	150	12	75	950	0.06	170	12	75	950	0.06	170	12			

Depth of cut

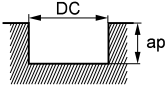

DC: Dia.

Work material	M					S					S								
	Precipitation hardening stainless steel, Cobalt chromium alloy										Heat resistant alloys								
DC (mm)	Cutting speed (m/min)	Main Spindle Revolution (min ⁻¹)	Feed per Tooth (mm/t)	Table Feed per Min. (mm/min)	Depth of cut ap (mm)	Cutting speed (m/min)	Main Spindle Revolution (min ⁻¹)	Feed per Tooth (mm/t)	Table Feed per Min. (mm/min)	Depth of cut ap (mm)	Cutting speed (m/min)	Main Spindle Revolution (min ⁻¹)	Feed per Tooth (mm/t)	Table Feed per Min. (mm/min)	Depth of cut ap (mm)				
10	60	1900	0.025	140	5	30	950	0.02	57	2	30	950	0.02	57	2				
12	60	1600	0.035	170	6	30	800	0.03	72	2.4	30	800	0.03	72	2.4				
16	60	1200	0.05	180	8	30	600	0.05	90	3.2	30	600	0.05	90	3.2				
20	60	950	0.05	140	10	30	480	0.05	72	4	30	480	0.05	72	4				
25	60	760	0.05	110	12	30	380	0.05	57	5	30	380	0.05	57	5				

Depth of cut

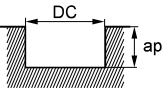

DC: Dia.

Note 1) For stainless steel, titanium and heat resistant alloys, the use of water-soluble coolant is effective.

Note 2) If the depth of cut is shallow, the revolution and feed rate can be increased.

Note 3) The irregular helix flute end mill has a large effect on controlling vibration when compared to standard end mills.

However, if the rigidity of the machine or the workpiece installation is poor, vibration or abnormal sound can occur.

In this case, please reduce the revolution and feed rate proportionately, or set a lower depth of cut.

■ Plunging

Work material	P						N						P						M						S										
	Carbon steel, Alloy steel, Mild Steel, Copper, Copper alloys												Pre-hardened steel, Carbon steel, Alloy steel, Alloy tool steel												Austenitic stainless steel, Ferritic and martensitic stainless steel, Titanium alloy										
Dia. DC (mm)	Cutting speed (m/min)	Main Spindle Revolution (min ⁻¹)	Feed per Revolution (mm/rev)	Table Feed per Min. (mm/min)	Drilled Depth ap (mm)	Step ap2 (mm)	Cutting speed (m/min)	Main Spindle Revolution (min ⁻¹)	Feed per Revolution (mm/rev)	Table Feed per Min. (mm/min)	Drilled Depth ap (mm)	Step ap2 (mm)	Cutting speed (m/min)	Main Spindle Revolution (min ⁻¹)	Feed per Revolution (mm/rev)	Table Feed per Min. (mm/min)	Drilled Depth ap (mm)	Step ap2 (mm)																	
10	100	3200	0.14	450	5	2.5	70	2200	0.09	200	5	2	60	1900	0.03	57	5	0.6																	
12	100	2700	0.14	380	6	2.5	70	1900	0.09	170	6	2	60	1600	0.03	48	6	0.6																	
16	100	2000	0.14	280	8	2.5	70	1400	0.09	130	8	2	60	1200	0.03	36	8	0.6																	
20	100	1600	0.14	220	10	2.5	70	1100	0.09	99	10	2	60	950	0.03	29	10	0.6																	
25	100	1300	0.14	180	12.5	2.5	70	890	0.09	80	12.5	2	60	760	0.03	23	12.5	0.6																	

Depth of cut 

Work material	M						S					
	Precipitation hardening stainless steel, Cobalt chromium alloy											
Dia. DC (mm)	Cutting speed (m/min)	Main Spindle Revolution (min ⁻¹)	Feed per Revolution (mm/rev)	Table Feed per Min. (mm/min)	Drilled Depth ap (mm)	Step ap2 (mm)						
10	40	1300	0.03	39	5	0.6						
12	40	1100	0.03	33	6	0.6						
16	40	800	0.03	24	8	0.6						
20	40	640	0.03	19	10	0.6						
25	40	510	0.03	15	12.5	0.6						

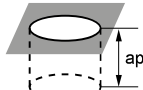
Depth of cut 

Note 1) For stainless steel, titanium and heat resistant alloys, the use of water-soluble coolant is effective.

Note 2) The irregular helix flute end mill has a larger effect on controlling vibration when compared to standard end mills.

However, if the rigidity of the machine or the workpiece installation is poor, vibration or abnormal sound can occur. In this case, please reduce the revolution and feed rate proportionately, or set a lower depth of cut.

INDEXABLE HEAD END MILLS

IMX-S4HV

Square head, Irregular helix, 4 flute

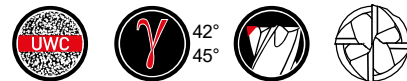

Carbon Steel, Alloy Steel, Cast Iron (<30HRC)	Tool Steel, Pre-Hardened Steel, Hardened Steel (≤45HRC)	Hardened Steel (≤55HRC)	Hardened Steel (>55HRC)	Austenitic Stainless Steel	Titanium Alloy, Heat Resistant Alloy	Copper Alloy	Aluminium Alloy
○	○			○	○	○	

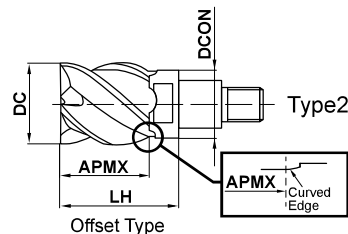
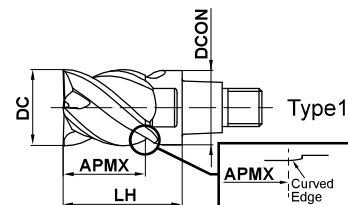

	DC ≤ 12	DC > 12			
	0	0			
	- 0.020	- 0.030			

● Irregular helix controls vibration and achieves stable machining even when machining difficult-to-cut materials and for applications with a long overhang.

(mm)

Order Number	DC	APMX	LH	DCON	Flutes	Grade	Type
						EP7020	
IMX10S4HV10010	10	10	16	9.7	4	●	1
IMX10S4HV12012	12	12.5	19	9.7	4	●	2
IMX12S4HV12012	12	12	19	11.7	4	●	1
IMX12S4HV14014	14	14.5	22.5	11.7	4	●	2
IMX16S4HV16016	16	16	24	15.5	4	●	1
IMX16S4HV18018	18	18.5	27	15.5	4	●	2
IMX20S4HV20020	20	20	30	19.5	4	●	1
IMX20S4HV22023	22	23	33	19.5	4	●	2
IMX25S4HV25025	25	25	37.5	24.5	4	●	1
IMX25S4HV28029	28	29	41.5	24.5	4	●	2
IMX25S4HV30031	30	31	43.5	24.5	4	●	2
IMX25S4HV32033	32	33	45.5	24.5	4	●	2

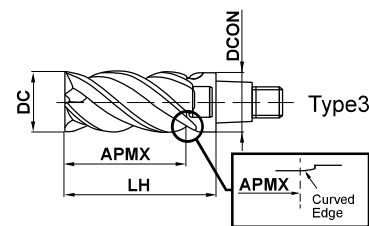

■ Long cutting edge type

(mm)

Order Number	DC	APMX	LH	DCON	Flutes	Grade	Type
						EP7020	
IMX16S4HV16032	16	32	40	15.5	4	●	3
IMX20S4HV20040	20	40	50	19.5	4	●	3

Note 1) The fastening size of the holder and head should be the same. (refer to Page J002.)

● : Inventory maintained.

IMX-S4HV-S

Square head, Irregular helix, with coolant hole, 4 flute



Carbon Steel, Alloy Steel, Cast Iron (<30HRC)	Tool Steel, Pre-Hardened Steel, Hardened Steel (≤45HRC)	Hardened Steel (≤55HRC)	Hardened Steel (>55HRC)	Austenitic Stainless Steel	Titanium Alloy, Heat Resistant Alloy	Copper Alloy	Aluminium Alloy
○	○			○	○	○	

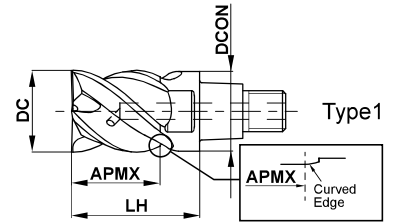

DC ≤ 12	DC > 12			
0 - 0.020	0 - 0.030			

- Coolant holes for each flute provides a stable coolant supply.
- Irregular helix controls vibration and achieves stable machining.

Order Number	DC	APMX	LH	DCON	Flutes	Grade	Type
						EP7020	
IMX10S4HV10010S	10	10	16	9.7	4	●	1
IMX12S4HV12012S	12	12	19	11.7	4	●	1
IMX16S4HV16016S	16	16	24	15.5	4	●	1
IMX20S4HV20020S	20	20	30	19.5	4	●	1
IMX25S4HV25025S	25	25	37.5	24.5	4	●	1

Note 1) The fastening size of the holder and head should be the same. (refer to Page J002.)

INDEXABLE HEAD END MILLS

SQUARE

BALL

RADIUS

TAPER

CHAMFER

ROUGHING

INDEXABLE HEAD END MILLS

IMX-S4HV/IMX-S4HV-S

Square head, Irregular helix (With/Without coolant hole), 4 flute

RECOMMENDED CUTTING CONDITIONS

■ Shoulder milling (L/D=3)

Other than the L/D = 3, use following recommended cutting conditions by multiplying the J003 page correction factor of the overhang length.

Work material	P						N						P						M						S										
	Carbon steel, Alloy steel, Mild Steel, Copper, Copper alloys												Pre-hardened steel, Carbon steel, Alloy steel, Alloy tool steel												Austenitic stainless steel, Ferritic and martensitic stainless steel, Titanium alloy										
Dia. DC (mm)	Cutting Speed (m/min)	Main Spindle Revolution (min ⁻¹)	Feed per Tooth (mm/t)	Table Feed per Min. (mm/min)	Depth of Cut ap (mm)	Cutting Width ae (mm)	Cutting Speed (m/min)	Main Spindle Revolution (min ⁻¹)	Feed per Tooth (mm/t)	Table Feed per Min. (mm/min)	Depth of Cut ap (mm)	Cutting Width ae (mm)	Cutting Speed (m/min)	Main Spindle Revolution (min ⁻¹)	Feed per Tooth (mm/t)	Table Feed per Min. (mm/min)	Depth of Cut ap (mm)	Cutting Width ae (mm)	Cutting Speed (m/min)	Main Spindle Revolution (min ⁻¹)	Feed per Tooth (mm/t)	Table Feed per Min. (mm/min)	Depth of Cut ap (mm)	Cutting Width ae (mm)											
10	150	4800	0.09	1700	10	2	120	3800	0.06	910	10	2	100	3200	0.075	960	10	2	100	3200	0.075	960	10	2											
12	150	4000	0.09	1400	12	2.4	120	3200	0.065	830	12	2.4	100	2700	0.08	860	12	2.4	100	2700	0.08	860	12	2.4											
16	150	3000	0.1	1200	16	3.2	120	2400	0.075	720	16	3.2	100	2000	0.09	720	16	3.2	100	2000	0.09	720	16	3.2											
20	150	2400	0.1	960	20	4	120	1900	0.075	570	20	4	100	1600	0.09	580	20	4	100	1600	0.09	580	20	4											
25	150	1900	0.12	910	25	5	120	1500	0.075	450	25	5	100	1300	0.09	470	25	5	100	1300	0.09	470	25	5											

Depth of cut

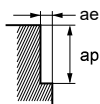

Work material	M						S						S											
	Precipitation hardening stainless steel, Cobalt chromium alloy												Heat resistant alloys											
Dia. DC (mm)	Cutting Speed (m/min)	Main Spindle Revolution (min ⁻¹)	Feed per Tooth (mm/t)	Table Feed per Min. (mm/min)	Depth of Cut ap (mm)	Cutting Width ae (mm)	Cutting Speed (m/min)	Main Spindle Revolution (min ⁻¹)	Feed per Tooth (mm/t)	Table Feed per Min. (mm/min)	Depth of Cut ap (mm)	Cutting Width ae (mm)	Cutting Speed (m/min)	Main Spindle Revolution (min ⁻¹)	Feed per Tooth (mm/t)	Table Feed per Min. (mm/min)	Depth of Cut ap (mm)	Cutting Width ae (mm)	Cutting Speed (m/min)	Main Spindle Revolution (min ⁻¹)	Feed per Tooth (mm/t)	Table Feed per Min. (mm/min)	Depth of Cut ap (mm)	Cutting Width ae (mm)
10	75	2400	0.06	580	10	2	40	1300	0.04	210	10	1	40	1300	0.04	210	10	1	40	1300	0.04	210	10	1
12	75	2000	0.065	520	12	2.4	40	1100	0.045	200	12	1.2	40	1100	0.045	200	12	1.2	40	1100	0.045	200	12	1.2
16	75	1500	0.075	450	16	3.2	40	800	0.05	160	16	1.6	40	800	0.05	160	16	1.6	40	800	0.05	160	16	1.6
20	75	1200	0.075	360	20	4	40	640	0.05	130	20	2	40	640	0.05	130	20	2	40	640	0.05	130	20	2
25	75	950	0.075	290	25	5	40	510	0.05	100	25	2.5	40	510	0.05	100	25	2.5	40	510	0.05	100	25	2.5

Depth of cut

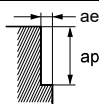

Note 1) For stainless steel, titanium and heat resistant alloys, the use of water-soluble coolant is effective.

Note 2) If the depth of cut is shallow, the revolution and feed rate can be increased.

Note 3) The irregular helix flute end mill has a large effect on controlling vibration when compared to standard end mills.

However, if the rigidity of the machine or the workpiece installation is poor, vibration or abnormal sound can occur.

In this case, please reduce the revolution and feed rate proportionately, or set a lower depth of cut.

Slot milling

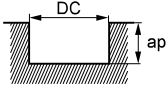
Work material	P					N					P					M					S																							
	Carbon steel, Alloy steel, Mild Steel, Copper, Copper alloys															Pre-hardened steel, Carbon steel, Alloy steel, Alloy tool steel															Austenitic stainless steel, Ferritic and martensitic stainless steel, Titanium alloy													
Dia. DC (mm)	Cutting speed (m/min)	Main Spindle Revolution (min ⁻¹)	Feed per Tooth (mm/t)	Table Feed per Min. (mm/min)	Depth of cut ap (mm)	Cutting speed (m/min)	Main Spindle Revolution (min ⁻¹)	Feed per Tooth (mm/t)	Table Feed per Min. (mm/min)	Depth of cut ap (mm)	Cutting speed (m/min)	Main Spindle Revolution (min ⁻¹)	Feed per Tooth (mm/t)	Table Feed per Min. (mm/min)	Depth of cut ap (mm)	Cutting speed (m/min)	Main Spindle Revolution (min ⁻¹)	Feed per Tooth (mm/t)	Table Feed per Min. (mm/min)	Depth of cut ap (mm)	Cutting speed (m/min)	Main Spindle Revolution (min ⁻¹)	Feed per Tooth (mm/t)	Table Feed per Min. (mm/min)	Depth of cut ap (mm)																			
10	100	3200	0.04	510	5	80	2500	0.03	300	5	75	2400	0.03	290	5	75	2400	0.03	290	5	75	2400	0.03	290	5																			
12	100	2700	0.05	540	6	80	2100	0.04	340	6	75	2000	0.04	320	6	75	2000	0.04	320	6	75	2000	0.04	320	6																			
16	100	2000	0.07	560	8	80	1600	0.05	320	8	75	1500	0.06	360	8	75	1500	0.06	360	8	75	1500	0.06	360	8																			
20	100	1600	0.07	450	10	80	1300	0.05	260	10	75	1200	0.06	290	10	75	1200	0.06	290	10	75	1200	0.06	290	10																			
25	100	1300	0.08	420	12	80	1000	0.05	200	12	75	950	0.06	230	12	75	950	0.06	230	12	75	950	0.06	230	12																			
Depth of cut																																												

DC: Dia.

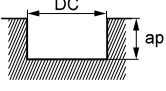
Work material	M					S					S																		
	Precipitation hardening stainless steel, Cobalt chromium alloy															Heat resistant alloys													
Dia. DC (mm)	Cutting speed (m/min)	Main Spindle Revolution (min ⁻¹)	Feed per Tooth (mm/t)	Table Feed per Min. (mm/min)	Depth of cut ap (mm)	Cutting speed (m/min)	Main Spindle Revolution (min ⁻¹)	Feed per Tooth (mm/t)	Table Feed per Min. (mm/min)	Depth of cut ap (mm)	Cutting speed (m/min)	Main Spindle Revolution (min ⁻¹)	Feed per Tooth (mm/t)	Table Feed per Min. (mm/min)	Depth of cut ap (mm)														
10	60	1900	0.025	190	5	30	950	0.02	76	2	30	950	0.02	76	2														
12	60	1600	0.035	220	6	30	800	0.03	96	2.4	30	800	0.03	96	2.4														
16	60	1200	0.05	240	8	30	600	0.05	120	3.2	30	600	0.05	120	3.2														
20	60	950	0.05	190	10	30	480	0.05	96	4	30	480	0.05	96	4														
25	60	760	0.05	150	12	30	380	0.05	76	5	30	380	0.05	76	5														
Depth of cut																													

DC: Dia.

Note 1) For stainless steel, titanium and heat resistant alloys, the use of water-soluble coolant is effective.

Note 2) If the depth of cut is shallow, the revolution and feed rate can be increased.

Note 3) The irregular helix flute end mill has a large effect on controlling vibration when compared to standard end mills.

However, if the rigidity of the machine or the workpiece installation is poor, vibration or abnormal sound can occur.

In this case, please reduce the revolution and feed rate proportionately, or set a lower depth of cut.



INDEXABLE HEAD END MILLS

SQUARE

BALL

RADIUS

TAPER

CHAMFER

ROUGHING

INDEXABLE HEAD END MILLS

IMX-S4HV

Square head, Irregular helix, Long cutting edge type, 4 flute,

RECOMMENDED CUTTING CONDITIONS

Shoulder milling

Work material		P						N						P						M						S									
		Carbon steel, Alloy steel, Mild Steel, Copper, Copper alloys												Pre-hardened steel, Carbon steel, Alloy steel, Alloy tool steel												Austenitic stainless steel, Ferritic and martensitic stainless steel, Titanium alloy									
L/D	Dia DC (mm)	Cutting Speed (m/min)	Main Spindle Revolution (min ⁻¹)	Feed per Tooth (mm/t)	Table Feed per Min. (mm/min)	Depth of Cut ap (mm)	Cutting Width ae (mm)	Cutting Speed (m/min)	Main Spindle Revolution (min ⁻¹)	Feed per Tooth (mm/t)	Table Feed per Min. (mm/min)	Depth of Cut ap (mm)	Cutting Width ae (mm)	Cutting Speed (m/min)	Main Spindle Revolution (min ⁻¹)	Feed per Tooth (mm/t)	Table Feed per Min. (mm/min)	Depth of Cut ap (mm)	Cutting Width ae (mm)																
4	16	100	2000	0.09	720	32	0.8	80	1600	0.07	450	32	0.8	60	1200	0.08	380	32	0.8																
	20	100	1600	0.09	580	40	1	80	1300	0.07	360	40	1	60	950	0.08	300	40	1																
6	16	60	1200	0.07	340	32	0.8	50	990	0.05	200	32	0.8	40	800	0.06	190	32	0.8																
	20	60	950	0.07	270	40	1	50	800	0.05	160	40	1	40	640	0.06	150	40	1																

The diagram illustrates the geometry of a shoulder mill cut. It shows a cylindrical workpiece with a diameter 'D'. A cutting tool is shown in cross-section, cutting a shoulder. The cutting width is labeled 'ae' and the depth of cut is labeled 'ap'.

INDEXABLE HEAD END MILLS

SQUARE

BALL

RADIUS

TAPER

CHAMFER

ROUGHING

Work material		M						S						S									
		Precipitation hardening stainless steel, Cobalt chromium alloy												Heat resistant alloys									
L/D	Dia DC (mm)	Cutting Speed (m/min)	Main Spindle Revolution (min ⁻¹)	Feed per Tooth (mm/t)	Table Feed per Min. (mm/min)	Depth of Cut ap (mm)	Cutting Width ae (mm)	Cutting Speed (m/min)	Main Spindle Revolution (min ⁻¹)	Feed per Tooth (mm/t)	Table Feed per Min. (mm/min)	Depth of Cut ap (mm)	Cutting Width ae (mm)	Cutting Speed (m/min)	Main Spindle Revolution (min ⁻¹)	Feed per Tooth (mm/t)	Table Feed per Min. (mm/min)	Depth of Cut ap (mm)	Cutting Width ae (mm)				
4	16	50	990	0.07	280	32	0.8	30	600	0.05	120	32	0.4										
	20	50	800	0.07	220	40	1	30	480	0.05	96	40	0.5										
6	16	30	600	0.05	120	32	0.8	20	400	0.04	64	32	0.4										
	20	30	480	0.05	96	40	1	20	320	0.04	51	40	0.5										

The diagram illustrates the geometry of a shoulder mill cut. It shows a cylindrical workpiece with a diameter 'D'. A cutting tool is shown in cross-section, cutting a shoulder. The cutting width is labeled 'ae' and the depth of cut is labeled 'ap'.

Note 1) For stainless steel, titanium and heat resistant alloys, the use of water-soluble coolant is effective.

Note 2) If the depth of cut is shallow, the revolution and feed rate can be increased.

Note 3) The irregular helix flute end mill has a large effect on controlling vibration when compared to standard end mills.

However, if the rigidity of the machine or the workpiece installation is poor, vibration or abnormal sound can occur.

In this case, please reduce the revolution and feed rate proportionately, or set a lower depth of cut.

Note 4) The length of the long cutting type is 2 times that of the standard head. L/D demonstrates +1 when installed to a holder of the same size.

IMX-S4HV

Square head, Irregular helix, Offset type, 4 flute,

RECOMMENDED CUTTING CONDITIONS

Shoulder milling

Work material		P						N						P						M						S									
		Carbon steel, Alloy steel, Mild Steel, Copper, Copper alloys												Pre-hardened steel, Carbon steel, Alloy steel, Alloy tool steel												Austenitic stainless steel, Ferritic and martensitic stainless steel, Titanium alloy									
L/D	Dia DC (mm)	Cutting Speed (m/min)	Main Spindle Revolution (min ⁻¹)	Feed per Tooth (mm/t)	Table Feed per Min. (mm/min)	Depth of Cut ap (mm)	Cutting Width ae (mm)	Cutting Speed (m/min)	Main Spindle Revolution (min ⁻¹)	Feed per Tooth (mm/t)	Table Feed per Min. (mm/min)	Depth of Cut ap (mm)	Cutting Width ae (mm)	Cutting Speed (m/min)	Main Spindle Revolution (min ⁻¹)	Feed per Tooth (mm/t)	Table Feed per Min. (mm/min)	Depth of Cut ap (mm)	Cutting Width ae (mm)	Cutting Speed (m/min)	Main Spindle Revolution (min ⁻¹)	Feed per Tooth (mm/t)	Table Feed per Min. (mm/min)	Depth of Cut ap (mm)	Cutting Width ae (mm)										
3	11	150	4300	0.09	1500	11	1.1	120	3500	0.06	840	11	1.1	100	2900	0.075	870	11	1.1																
	12	150	4000	0.09	1400	12	1.2	120	3200	0.06	770	12	1.2	100	2700	0.075	810	12	1.2																
	13	150	3700	0.09	1300	13	1.3	120	2900	0.065	750	13	1.3	100	2400	0.08	770	13	1.3																
	14	150	3400	0.09	1200	14	1.4	120	2700	0.065	700	14	1.4	100	2300	0.08	740	14	1.4																
	17	150	2800	0.1	1100	17	1.7	120	2200	0.075	660	17	1.7	100	1900	0.08	610	17	1.7																
	18	150	2700	0.1	1100	18	1.8	120	2100	0.075	630	18	1.8	100	1800	0.09	650	18	1.8																
	22	150	2200	0.1	880	22	2.2	120	1700	0.075	510	22	2.2	100	1400	0.09	500	22	2.2																
	28	150	1700	0.12	820	28	2.8	120	1400	0.075	420	28	2.8	100	1100	0.09	400	28	2.8																
	30	150	1600	0.12	770	30	3	120	1300	0.075	390	30	3	100	1100	0.09	400	30	3																
	32	150	1500	0.12	720	32	3.2	120	1200	0.075	360	32	3.2	100	990	0.09	360	32	3.2																
5	11	90	2600	0.07	730	11	0.4	70	2000	0.05	400	11	0.4	60	1700	0.06	410	11	0.4																
	12	90	2400	0.07	670	12	0.5	70	1900	0.05	380	12	0.5	60	1600	0.06	380	12	0.5																
	13	90	2200	0.07	620	13	0.5	70	1700	0.05	340	13	0.5	60	1500	0.06	360	13	0.5																
	14	90	2000	0.07	560	14	0.6	70	1600	0.05	320	14	0.6	60	1400	0.06	340	14	0.6																
	17	90	1700	0.08	540	17	0.7	70	1300	0.06	310	17	0.7	60	1100	0.07	310	17	0.7																
	18	90	1600	0.08	510	18	0.7	70	1200	0.06	290	18	0.7	60	1100	0.07	310	18	0.7																
	22	90	1300	0.08	420	22	0.9	70	1000	0.06	240	22	0.9	60	870	0.07	240	22	0.9																
	28	90	1000	0.1	400	28	1.1	70	800	0.06	190	28	1.1	60	680	0.07	190	28	1.1																
	30	90	950	0.1	380	30	1.2	70	740	0.06	180	30	1.2	60	640	0.07	180	30	1.2																
	32	90	900	0.1	360	32	1.3	70	700	0.06	170	32	1.3	60	600	0.07	170	32	1.3																
7	11	60	1700	0.06	410	11	0.2	50	1400	0.04	220	11	0.2	32	930	0.05	190	11	0.2																
	12	60	1600	0.06	380	12	0.2	50	1300	0.04	210	12	0.2	32	850	0.05	170	12	0.2																
	13	60	1500	0.06	360	13	0.3	50	1200	0.05	240	13	0.3	32	780	0.06	190	13	0.3																
	14	60	1400	0.06	340	14	0.3	50	1100	0.05	220	14	0.3	32	730	0.06	180	14	0.3																
	17	60	1100	0.07	310	17	0.3	50	940	0.05	190	17	0.3	32	600	0.06	140	17	0.3																
	18	60	1100	0.07	310	18	0.4	50	880	0.05	180	18	0.4	32	570	0.06	140	18	0.4																
	22	60	870	0.07	240	22	0.4	50	720	0.05	140	22	0.4	32	460	0.06	110	22	0.4																
	28	60	680	0.08	220	28	0.6	50	570	0.05	110	28	0.6	32	360	0.06	86	28	0.6																
	30	60	640	0.08	200	30	0.6	50	530	0.05	110	30	0.6	32	340	0.06	82	30	0.6																
	32	60	600	0.08	190	32	0.6	50	500	0.05	100	32	0.6	32	320	0.06	77	32	0.6																

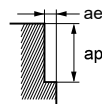

Note 1) For stainless steel, titanium and heat resistant alloys, the use of water-soluble coolant is effective.

Note 2) If the depth of cut is shallow, the revolution and feed rate can be increased.

Note 3) The irregular helix flute end mill has a large effect on controlling vibration when compared to standard end mills.

However, if the rigidity of the machine or the workpiece installation is poor, vibration or abnormal sound can occur.

In this case, please reduce the revolution and feed rate proportionately, or set a lower depth of cut.

INDEXABLE HEAD END MILLS

SQUARE

BALL

RADIUS

TAPER

CHAMFER

ROUGHING

INDEXABLE HEAD END MILLS

IMX-S4HV

Square head, Irregular helix, Offset type, 4 flute

RECOMMENDED CUTTING CONDITIONS

Shoulder milling

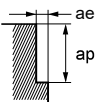
Work material		M						S					
		Precipitation hardening stainless steel, Cobalt chromium alloy						Heat resistant alloys					
L/D	Dia DC (mm)	Cutting Speed (m/min)	Main Spindle Revolution (min ⁻¹)	Feed per Tooth (mm/t)	Table Feed per Min. (mm/min)	Depth of Cut ap (mm)	Cutting Width ae (mm)	Cutting Speed (m/min)	Main Spindle Revolution (min ⁻¹)	Feed per Tooth (mm/t)	Table Feed per Min. (mm/min)	Depth of Cut ap (mm)	Cutting Width ae (mm)
3	11	75	2200	0.06	530	11	1.1	30	870	0.04	140	11	0.8
	12	75	2000	0.06	480	12	1.2	30	800	0.04	130	12	0.9
	13	75	1800	0.065	470	13	1.3	30	730	0.045	130	13	1
	14	75	1700	0.065	440	14	1.4	30	680	0.045	120	14	1.1
	17	75	1400	0.065	360	17	1.7	40	750	0.045	140	17	1.3
	18	75	1300	0.075	390	18	1.8	40	710	0.05	140	18	1.4
	22	75	1100	0.075	330	22	2.2	40	580	0.05	120	22	1.7
	28	75	850	0.075	260	28	2.8	40	450	0.05	90	28	2.1
	30	75	800	0.075	240	30	3	40	420	0.05	84	30	2.3
	32	75	750	0.075	230	32	3.2	40	400	0.05	80	32	2.4
5	11	50	1400	0.05	280	11	0.4	10	290	0.03	35	11	0.3
	12	50	1300	0.05	260	12	0.5	10	270	0.03	32	12	0.4
	13	50	1200	0.05	240	13	0.5	10	240	0.04	38	13	0.4
	14	50	1100	0.05	220	14	0.6	10	230	0.04	37	14	0.4
	17	50	940	0.06	230	17	0.7	19	360	0.04	58	17	0.5
	18	50	880	0.06	210	18	0.7	19	340	0.04	54	18	0.6
	22	50	720	0.06	170	22	0.9	19	270	0.04	43	22	0.7
	28	50	570	0.06	140	28	1.1	19	220	0.04	35	28	0.8
	30	50	530	0.06	130	30	1.2	19	200	0.04	32	30	0.9
	32	50	500	0.06	120	32	1.3	19	190	0.04	30	32	1
7	11	24	690	0.04	110	11	0.2	-	-	-	-	-	-
	12	24	640	0.04	100	12	0.2	-	-	-	-	-	-
	13	24	590	0.05	120	13	0.3	-	-	-	-	-	-
	14	24	550	0.05	110	14	0.3	-	-	-	-	-	-
	17	24	450	0.05	90	17	0.3	-	-	-	-	-	-
	18	24	420	0.05	84	18	0.4	-	-	-	-	-	-
	22	24	350	0.05	70	22	0.4	-	-	-	-	-	-
	28	24	270	0.05	54	28	0.6	-	-	-	-	-	-
	30	24	250	0.05	50	30	0.6	-	-	-	-	-	-
	32	24	240	0.05	48	32	0.6	-	-	-	-	-	-
Depth of cut													

Note 1) For stainless steel, titanium alloy and heat resistant alloy, the use of water-soluble coolant is effective.

Note 2) If the depth of cut is shallow, the revolution and feed rate can be increased.

Note 3) The irregular helix flute end mill has a large effect on controlling vibration when compared to standard end mills.

However, if the rigidity of the machine or the workpiece installation is poor, vibration or abnormal sound can occur.

In this case, please reduce the revolution and feed rate proportionately, or set a lower depth of cut.

IMX-S3A

Square head, For aluminium alloy, 3 flute



Carbon Steel, Alloy Steel, Cast Iron (<30HRC)	Tool Steel, Pre-Hardened Steel, Hardened Steel (≤45HRC)	Hardened Steel (≤55HRC)	Hardened Steel (>55HRC)	Austenitic Stainless Steel	Titanium Alloy, Heat Resistant Alloy	Copper Alloy	Aluminium Alloy
---	---	-------------------------	-------------------------	----------------------------	--------------------------------------	--------------	-----------------

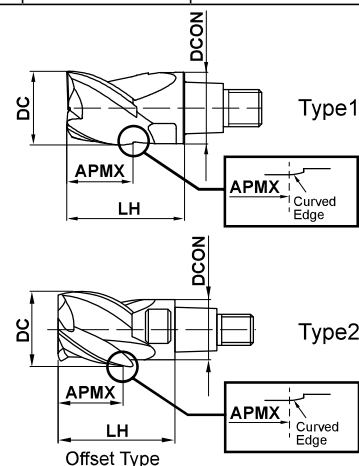

	DC ≤ 12	DC > 12			
	0 - 0.020	0 - 0.030			

● High efficiency machining is possible due to the polished rake face and sharp cutting edge.

(mm)

Order Number	DC	APMX	LH	DCON	Flutes	Grade	
						ET2020	Type
IMX10S3A10008	10	8	16	9.7	3	●	1
IMX10S3A12010	12	10.1	19	9.7	3	●	2
IMX12S3A12009	12	9.6	19	11.7	3	●	1
IMX12S3A14011	14	11.7	22.5	11.7	3	●	2
IMX16S3A16012	16	12.8	24	15.5	3	●	1
IMX16S3A18014	18	14.9	27	15.5	3	●	2
IMX20S3A20016	20	16	30	19.5	3	●	1
IMX20S3A22018	22	18.6	33	19.5	3	●	2
IMX25S3A25020	25	20	37.5	24.5	3	●	1
IMX25S3A28023	28	23.4	41.5	24.5	3	●	2

Note 1) The fastening size of the holder and head should be the same. (refer to Page J002.)



INDEXABLE HEAD END MILLS

SQUARE

BALL

RADIUS

TAPER

CHAMFER

ROUGHING

● : Inventory maintained.

INDEXABLE HEAD END MILLS

IMX-S3A

Square head, For aluminium alloy, 3 flute,

RECOMMENDED CUTTING CONDITIONS

Shoulder milling (L/D=3)

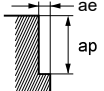
N						
Work Material	Aluminium alloy					
Dia. DC (mm)	Cutting Speed (m/min)	Main Spindle Revolution (min ⁻¹)	Feed per Tooth (mm/t)	Table Feed per Min. (mm/min)	Depth of Cut ap (mm)	Cutting Width ae (mm)
10	500	16000	0.117	5600	8	3
12	500	13000	0.118	4600	9.6	3.6
16	500	9900	0.153	4500	12.8	4.8
20	500	8000	0.175	4200	16	6
25	500	6400	0.211	4100	20	7.5
Depth of Cut						

Shoulder milling (L/D=5)

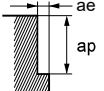
N						
Work Material	Aluminium alloy					
Dia. DC (mm)	Cutting Speed (m/min)	Main Spindle Revolution (min ⁻¹)	Feed per Tooth (mm/t)	Table Feed per Min. (mm/min)	Depth of Cut ap (mm)	Cutting Width ae (mm)
10	300	9500	0.09	2600	8	1.2
12	300	8000	0.09	2200	9.6	1.44
16	300	6000	0.12	2200	12.8	1.92
20	300	4800	0.14	2000	16	2.4
25	300	3800	0.17	1900	20	3
Depth of Cut						

Shoulder milling (L/D=7)

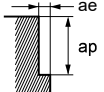
N						
Work Material	Aluminium alloy					
Dia. DC (mm)	Cutting Speed (m/min)	Main Spindle Revolution (min ⁻¹)	Feed per Tooth (mm/t)	Table Feed per Min. (mm/min)	Depth of Cut ap (mm)	Cutting Width ae (mm)
10	200	6400	0.08	1500	8	0.6
12	200	5300	0.08	1300	9.6	0.72
16	200	4000	0.11	1300	12.8	0.96
20	200	3200	0.12	1200	16	1.2
25	200	2500	0.15	1100	20	1.5
Depth of Cut						

Slot milling (L/D=3)

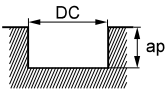
N					
Work Material	Aluminium alloy				
Dia. DC (mm)	Cutting Speed (m/min)	Main Spindle Revolution (min ⁻¹)	Feed per Tooth (mm/t)	Table Feed per Min. (mm/min)	Depth of Cut ap (mm)
10	500	16000	0.068	3300	5
12	500	13000	0.072	2800	6
16	500	9900	0.093	2800	8
20	500	8000	0.108	2600	10
25	500	6400	0.127	2400	12.5
Depth of Cut					

DC: Dia.

Plunging (L/D=3)

N						
Work Material	Aluminium alloy					
Dia. DC (mm)	Cutting Speed (m/min)	Main Spindle Revolution (min ⁻¹)	Feed per Revolution (mm/rev)	Table Feed per Min. (mm/min)	Drilled Depth ap (mm)	Step ap2 (mm)
10	300	9500	0.1	950	5	2.5
12	300	8000	0.1	800	6	2.5
16	300	6000	0.1	600	8	2.5
20	300	4800	0.1	480	10	2.5
25	300	3800	0.1	380	12.5	2.5
Depth of Cut						

Note 1) The use of water-soluble coolant is recommended.

Note 2) Vibration may occur if the rigidity of machine or workpiece is low.

In this case, please reduce the revolution and feed rate proportionately, or set a lower depth of cut.

IMX-S3A

Square head, For aluminium alloy, Offset type, 3 flute,

RECOMMENDED CUTTING CONDITIONS

■ Shoulder milling

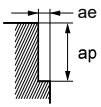
L/D		N					
		Aluminium alloy					
Dia. DC (mm)	Cutting Speed (m/min)	Main Spindle Revolution (min ⁻¹)	Feed per Tooth (mm/t)	Table Feed per Min. (mm/min)	Depth of Cut ap (mm)	Cutting Width ae (mm)	
3	12	500	13000	0.117	4600	9.6	2.4
	14	500	11000	0.118	3900	11.2	2.8
	18	500	8800	0.153	4000	14.4	3.6
	22	500	7200	0.175	3800	17.6	4.4
	28	500	5700	0.211	3600	22.4	5.6
5	12	300	8000	0.09	2200	9.6	1.0
	14	300	6800	0.09	1800	11.2	1.1
	18	300	5300	0.12	1900	14.4	1.4
	22	300	4300	0.14	1800	17.6	1.8
	28	300	3400	0.17	1700	22.4	2.2
Depth of cut							

Note 1) The use of water-soluble coolant is recommended.

Note 2) Vibration may occur if the rigidity of machine or workpiece is low.

In this case, please reduce the revolution and feed rate proportionately, or set a lower depth of cut.

INDEXABLE HEAD END MILLS

IMX-R4F

Roughing head, 4 flute



Carbon Steel, Alloy Steel, Cast Iron (<30HRC)	Tool Steel, Pre-Hardened Steel, Hardened Steel (≤45HRC)	Hardened Steel (≤55HRC)	Hardened Steel (>55HRC)	Austenitic Stainless Steel	Titanium Alloy, Heat Resistant Alloy	Copper Alloy	Aluminium Alloy
○	○			○	○	○	

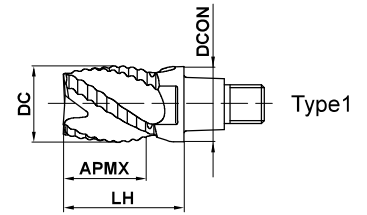

INDEXABLE HEAD END MILLS

SQUARE

BALL

RADIUS

TAPER

CHAMFER

ROUGHING

- The roughing edge geometry reduces cutting resistance. Effective when rigidity of the machine or workpiece is low.

(mm)

Order Number	DC	APMX	LH	DCON	Flutes	Grade	Type
						EP7020	
IMX10R4F10010	10	10.5	16	9.7	4	●	1
IMX12R4F12012	12	12.5	19	11.7	4	●	1
IMX16R4F16016	16	16.5	24	15.5	4	●	1
IMX20R4F20021	20	21	30	19.5	4	●	1
IMX25R4F25026	25	26	37.5	24.5	4	●	1

Note 1) The fastening size of the holder and head should be the same. (refer to Page J002.)

● : Inventory maintained.

RECOMMENDED CUTTING CONDITIONS

■ Shoulder milling (L/D=3)

Other than the L/D = 3, use following recommended cutting conditions by multiplying the J003 page correction factor of the overhang length.

Work material	P						N						P						M						S										
	Carbon steel, Alloy steel, Mild Steel, Copper, Copper alloys												Pre-hardened steel, Carbon steel, Alloy steel, Alloy tool steel												Austenitic stainless steel, Ferritic and martensitic stainless steel, Titanium alloy										
Dia. DC (mm)	Cutting Speed (m/min)	Main Spindle Revolution (min ⁻¹)	Feed per Tooth (mm/t)	Table Feed per Min. (mm/min)	Depth of Cut ap (mm)	Cutting Width ae (mm)	Cutting Speed (m/min)	Main Spindle Revolution (min ⁻¹)	Feed per Tooth (mm/t)	Table Feed per Min. (mm/min)	Depth of Cut ap (mm)	Cutting Width ae (mm)	Cutting Speed (m/min)	Main Spindle Revolution (min ⁻¹)	Feed per Tooth (mm/t)	Table Feed per Min. (mm/min)	Depth of Cut ap (mm)	Cutting Width ae (mm)	Cutting Speed (m/min)	Main Spindle Revolution (min ⁻¹)	Feed per Tooth (mm/t)	Table Feed per Min. (mm/min)	Depth of Cut ap (mm)	Cutting Width ae (mm)											
10	150	4800	0.045	860	8	4	120	3800	0.03	460	8	4	100	3200	0.038	490	8	4	100	3200	0.038	490	8	4											
12	150	4000	0.045	720	9.6	4.8	120	3200	0.033	420	9.6	4.8	100	2700	0.04	430	9.6	4.8	100	2700	0.04	430	9.6	4.8											
16	150	3000	0.05	600	12.8	6.4	120	2400	0.038	360	12.8	6.4	100	2000	0.045	360	12.8	6.4	100	2000	0.045	360	12.8	6.4											
20	150	2400	0.05	480	16	8	120	1900	0.038	290	16	8	100	1600	0.045	290	16	8	100	1600	0.045	290	16	8											
25	150	1900	0.06	460	20	10	120	1500	0.038	230	20	10	100	1300	0.045	230	20	10	100	1300	0.045	230	20	10											

Depth of cut

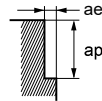

Work material	M						S						S											
	Precipitation hardening stainless steel, Cobalt chromium alloy												Heat resistant alloys											
Dia. DC (mm)	Cutting Speed (m/min)	Main Spindle Revolution (min ⁻¹)	Feed per Tooth (mm/t)	Table Feed per Min. (mm/min)	Depth of Cut ap (mm)	Cutting Width ae (mm)	Cutting Speed (m/min)	Main Spindle Revolution (min ⁻¹)	Feed per Tooth (mm/t)	Table Feed per Min. (mm/min)	Depth of Cut ap (mm)	Cutting Width ae (mm)	Cutting Speed (m/min)	Main Spindle Revolution (min ⁻¹)	Feed per Tooth (mm/t)	Table Feed per Min. (mm/min)	Depth of Cut ap (mm)	Cutting Width ae (mm)	Cutting Speed (m/min)	Main Spindle Revolution (min ⁻¹)	Feed per Tooth (mm/t)	Table Feed per Min. (mm/min)	Depth of Cut ap (mm)	Cutting Width ae (mm)
10	75	2400	0.03	290	8	4	40	1300	0.04	210	8	1	40	1300	0.04	210	8	1	40	1300	0.04	210	8	1
12	75	2000	0.033	260	9.6	4.8	40	1100	0.045	200	9.6	1.2	40	1100	0.045	200	9.6	1.2	40	1100	0.045	200	9.6	1.2
16	75	1500	0.038	230	12.8	6.4	40	800	0.05	160	12.8	1.6	40	800	0.05	160	12.8	1.6	40	800	0.05	160	12.8	1.6
20	75	1200	0.038	180	16	8	40	640	0.05	130	16	2	40	640	0.05	130	16	2	40	640	0.05	130	16	2
25	75	950	0.038	140	20	10	40	510	0.05	100	20	2.5	40	510	0.05	100	20	2.5	40	510	0.05	100	20	2.5

Depth of cut

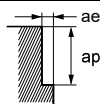

Note 1) For stainless steel, titanium and heat resistant alloys, the use of water-soluble coolant is effective.

Note 2) If the depth of cut is shallow, the revolution and feed rate can be increased.

Note 3) Vibration may occur if the rigidity of machine or workpiece is low.

In this case, please reduce the revolution and feed rate proportionately, or set a lower depth of cut.

INDEXABLE HEAD END MILLS

IMX-R4F

Roughing head, 4 flute

RECOMMENDED CUTTING CONDITIONS

■ Slot milling

Work material	P					N					P					M					S																							
	Carbon steel, Alloy steel, Mild Steel, Copper, Copper alloys															Pre-hardened steel, Carbon steel, Alloy steel, Alloy tool steel															Austenitic stainless steel, Ferritic and martensitic stainless steel, Titanium alloy													
DC (mm)	Cutting Speed (m/min)	Main Spindle Revolution (min ⁻¹)	Feed per Tooth (mm/t)	Table Feed per Min. (mm/min)	Depth of Cut ap (mm)	Cutting Speed (m/min)	Main Spindle Revolution (min ⁻¹)	Feed per Tooth (mm/t)	Table Feed per Min. (mm/min)	Depth of Cut ap (mm)	Cutting Speed (m/min)	Main Spindle Revolution (min ⁻¹)	Feed per Tooth (mm/t)	Table Feed per Min. (mm/min)	Depth of Cut ap (mm)	Cutting Speed (m/min)	Main Spindle Revolution (min ⁻¹)	Feed per Tooth (mm/t)	Table Feed per Min. (mm/min)	Depth of Cut ap (mm)																								
10	100	3200	0.04	510	5	80	2500	0.03	300	5	60	1900	0.02	150	4																													
12	100	2700	0.045	490	6	80	2100	0.032	270	6	60	1600	0.025	160	4.8																													
16	100	2000	0.05	400	8	80	1600	0.038	240	8	60	1200	0.03	140	6.4																													
20	100	1600	0.05	320	10	80	1300	0.038	200	10	60	950	0.034	130	8																													
25	100	1300	0.06	310	12	80	1000	0.038	150	12	60	760	0.034	100	10																													

Depth of cut

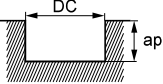

DC: Dia.

Work material	M					S					
	Precipitation hardening stainless steel, Cobalt chromium alloy										
DC (mm)	Cutting Speed (m/min)	Main Spindle Revolution (min ⁻¹)	Feed per Tooth (mm/t)	Table Feed per Min. (mm/min)	Depth of Cut ap (mm)	DC (mm)	Cutting Speed (m/min)	Main Spindle Revolution (min ⁻¹)	Feed per Tooth (mm/t)	Table Feed per Min. (mm/min)	Depth of Cut ap (mm)
10	40	1300	0.016	83	4						
12	40	1100	0.02	88	4.8						
16	40	800	0.024	77	6.4						
20	40	640	0.027	70	8						
25	40	510	0.027	55	10						

Depth of cut

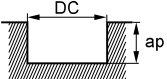

DC: Dia.

Note 1) For stainless steel, titanium and heat resistant alloys, the use of water-soluble coolant is effective.

Note 2) If the depth of cut is shallow, the revolution and feed rate can be increased.

Note 3) Vibration may occur if the rigidity of machine or workpiece is low.

In this case, please reduce the revolution and feed rate proportionately, or set a lower depth of cut.

INDEXABLE HEAD END MILLS

SQUARE

BALL

RADIUS

TAPER

CHAMFER

ROUGHING

IMX-RC4F-C NEW

Roughing head, with coolant hole, 4 flute



Carbon Steel, Alloy Steel, Cast Iron (<30HRC)	Tool Steel, Pre-Hardened Steel, Hardened Steel (≤45HRC)	Hardened Steel (≤55HRC)	Hardened Steel (>55HRC)	Austenitic Stainless Steel	Titanium Alloy	Copper Alloy	Aluminium Alloy
○				○	◎		

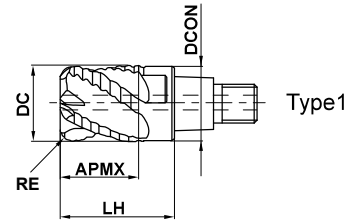

- The roughing edge geometry reduces cutting resistance. Effective when the rigidity of the machine or work material is low.
- Centre through coolant hole provides excellent chip evacuation.

Order Number	DC	RE	APMX	LH	DCON	Flutes	Grade	Type
							EP7020	
IMX10RC4F100R05010C	10	0.5	10.5	16	9.7	4	●	1
IMX10RC4F100R10010C	10	1	10.5	16	9.7	4	●	1
IMX12RC4F120R05012C	12	0.5	12.5	19	11.7	4	●	1
IMX12RC4F120R10012C	12	1	12.5	19	11.7	4	●	1
IMX12RC4F120R15012C	12	1.5	12.5	19	11.7	4	●	1
IMX12RC4F120R20012C	12	2	12.5	19	11.7	4	●	1
IMX16RC4F160R05016C	16	0.5	16.5	24	15.5	4	●	1
IMX16RC4F160R10016C	16	1	16.5	24	15.5	4	●	1
IMX16RC4F160R15016C	16	1.5	16.5	24	15.5	4	●	1
IMX16RC4F160R20016C	16	2	16.5	24	15.5	4	●	1
IMX16RC4F160R30016C	16	3	16.5	24	15.5	4	●	1
IMX20RC4F200R05021C	20	0.5	21	30	19.5	4	●	1
IMX20RC4F200R10021C	20	1	21	30	19.5	4	●	1
IMX20RC4F200R20021C	20	2	21	30	19.5	4	●	1
IMX20RC4F200R30021C	20	3	21	30	19.5	4	●	1

Note 1) The fastening size of the holder and head should be the same. (refer to Page J002.)

↩
 INDEXABLE HEAD END MILLS
 SQUARE
 BALL
 RADIUS
 TAPER
 CHAMFER
 ROUGHING

● : Inventory maintained.

INDEXABLE HEAD END MILLS

IMX-RC4F-C NEW

Roughing head, with coolant hole, 4 flute

RECOMMENDED CUTTING CONDITIONS

■ Shoulder milling (L/D=3)

Other than the L/D = 3, use following recommended cutting conditions by multiplying the J003 page correction factor of the overhang length.

Work material	P					M		S		M					
	Carbon steel, Alloy steel, Mild Steel					Austenitic stainless steel, Ferritic and martensitic stainless steel, Titanium alloy					Precipitation hardening stainless steel				
Dia. DC (mm)	Cutting Speed (m/min)	Main Spindle Revolution (min ⁻¹)	Table Feed per Min. (mm/min)	Depth of Cut ap (mm)	Cutting Width ae (mm)	Cutting Speed (m/min)	Main Spindle Revolution (min ⁻¹)	Table Feed per Min. (mm/min)	Depth of Cut ap (mm)	Cutting Width ae (mm)	Cutting Speed (m/min)	Main Spindle Revolution (min ⁻¹)	Table Feed per Min. (mm/min)	Depth of Cut ap (mm)	Cutting Width ae (mm)
10	150	4800	860	8	4	70	2000	320	8	4	60	1900	230	8	4
12	150	4000	800	9.6	4.8	70	1900	340	9.6	4.8	60	1600	230	9.6	4.8
16	150	3000	600	12.8	6.4	70	1400	280	12.8	6.4	60	1200	200	12.8	6.4
20	150	2400	530	16	8	70	1100	220	16	8	60	950	180	16	8

Diagram illustrating the cutting parameters for shoulder milling: ae (Cutting Width) and ap (Depth of Cut).

INDEXABLE HEAD END MILLS

SQUARE

■ Slot milling

Work material	P				M		S		M			
	Carbon steel, Alloy steel, Mild Steel				Austenitic stainless steel, Ferritic and martensitic stainless steel, Titanium alloy				Precipitation hardening stainless steel			
Dia. DC (mm)	Cutting Speed (m/min)	Main Spindle Revolution (min ⁻¹)	Table Feed per Min. (mm/min)	Depth of Cut ap (mm)	Cutting Speed (m/min)	Main Spindle Revolution (min ⁻¹)	Table Feed per Min. (mm/min)	Depth of Cut ap (mm)	Cutting Speed (m/min)	Main Spindle Revolution (min ⁻¹)	Table Feed per Min. (mm/min)	Depth of Cut ap (mm)
10	100	3200	510	5	60	1900	230	5	40	1300	100	5
12	100	2700	490	6	60	1600	260	6	40	1100	110	6
16	100	2000	400	8	60	1200	220	8	40	800	96	8
20	100	1600	350	10	60	950	170	10	40	640	90	10

Diagram illustrating the cutting parameters for slot milling: DC (Diameter) and ap (Depth of Cut).

DC: Dia.

Note 1) Vibration may occur if the rigidity of machine or workpiece is low. In this case, please reduce the revolution and feed rate proportionately, or set a lower depth of cut.

Note 2) If the depth of cut is shallow, the revolution and feed rate can be increased.

Note 3) For stainless steel, titanium alloy, the use of water-soluble coolant is effective.

BALL

RADIUS

TAPER

CHAMFER

ROUGHING

IMX-B2S

Ball nose head, For hardened steel, 2 flute



Carbon Steel, Alloy Steel, Cast Iron (<30HRC)	Tool Steel, Pre-Hardened Steel, Hardened Steel (<=45HRC)	Hardened Steel (<=55HRC)	Hardened Steel (55-65HRC)	Austenitic Stainless Steel	Titanium Alloy, Heat Resistant Alloy	Copper Alloy	Aluminium Alloy
---	--	--------------------------	---------------------------	----------------------------	--------------------------------------	--------------	-----------------

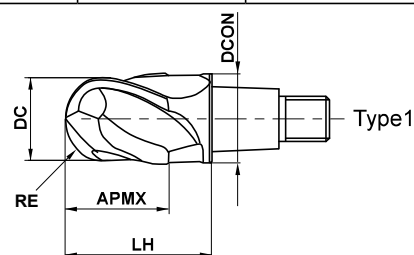

RE ≥ 8				
±0.020				

● Ideal for machining with long overhangs.

Order Number	RE	DC	APMX	LH	DCON	Flutes	Grade	Type
							EP8110	
IMX16B2S16016	8	16	16	24	15.5	2	★	1
IMX20B2S20020	10	20	20	30	19.5	2	★	1

Note 1) The fastening size of the holder and head should be the same. (refer to Page J002.)

RECOMMENDED CUTTING CONDITIONS

■ Shoulder milling (L/D=3)

Other than the L/D = 3, use following recommended cutting conditions by multiplying the J003 page correction factor of the overhang length.

Work material	H										
	Hardened Steel (55-65 HRC)										
	$\alpha \leq 15^\circ$				$\alpha > 15^\circ$				Depth of cut ap (mm)	Cutting Width ae (mm)	
Dia. DC (mm)	RE (mm)	Cutting Speed (m/min)	Main Spindle Revolution (min ⁻¹)	Feed per Tooth (mm/t)	Table Feed per Min. (mm/min)	Cutting Speed (m/min)	Main Spindle Revolution (min ⁻¹)	Feed per Tooth (mm/t)			Table Feed per Min. (mm/min)
16	8	300	6000	0.14	1700	150	3000	0.08	480	0.3	1.6
20	10	300	4800	0.14	1300	150	2400	0.08	380	0.3	2

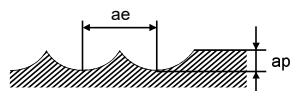

Note 1) If the depth of cut is shallow, the revolution and feed rate can be increased.

Note 2) α is the inclination angle of the machined surface.

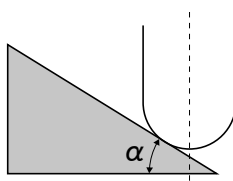

★ : Inventory maintained in Japan.

INDEXABLE HEAD END MILLS

IMX-B4S NEW

Ball nose head, For hardened steel, 4 flute



Carbon Steel, Alloy Steel, Cast Iron (<30HRC)	Tool Steel, Pre-Hardened Steel, Hardened Steel (<=45HRC)	Hardened Steel (<=55HRC)	Hardened Steel (>55HRC)	Austenitic Stainless Steel	Titanium Alloy, Heat Resistant Alloy	Copper Alloy	Aluminium Alloy
---	--	--------------------------	-------------------------	----------------------------	--------------------------------------	--------------	-----------------

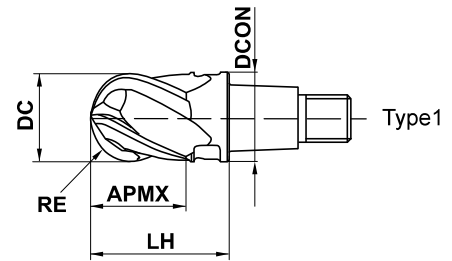

INDEXABLE HEAD END MILLS

SQUARE

BALL

RADIUS

TAPER

CHAMFER

ROUGHING

RE ≥ 8				
±0.020				

● High efficiency machining is realized even when only machining with the tip.

Order Number	RE	DC	APMX	LH	DCON	Flutes	Grade	Type
							EP8110	
IMX16B4S16016	8	16	16	24	15.5	4	★	1
IMX20B4S20020	10	20	20	30	19.5	4	★	1

Note 1) The fastening size of the holder and head should be the same. (refer to Page J002.)

RECOMMENDED CUTTING CONDITIONS

■ Shoulder milling (L/D=3)

Other than the L/D = 3, use following recommended cutting conditions by multiplying the J003 page correction factor of the overhang length.

Work material		H									
Inclination angle		$\alpha \leq 15^\circ$				$\alpha > 15^\circ$				Depth of cut ap (mm)	Cutting Width ae (mm)
Dia. DC (mm)	RE (mm)	Cutting Speed (m/min)	Main Spindle Revolution (min ⁻¹)	Feed per Tooth (mm/t)	Table Feed per Min. (mm/min)	Cutting Speed (m/min)	Main Spindle Revolution (min ⁻¹)	Feed per Tooth (mm/t)	Table Feed per Min. (mm/min)		
16	8	300	6000	0.07	1700	150	3000	0.06	720	0.3	1.6
20	10	300	4800	0.07	1300	150	2400	0.06	580	0.3	2

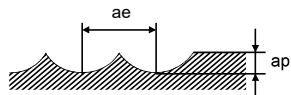

Note 1) If the depth of cut is shallow, the revolution and feed rate can be increased.

Note 2) α is the inclination angle of the machined surface.

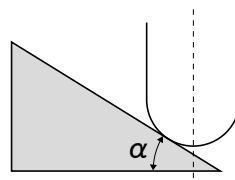

★ : Inventory maintained in Japan.

IMX-B3FV

Ball nose head, For high efficiency machining, Irregular helix, 3 flute



Carbon Steel, Alloy Steel, Cast Iron (<30HRC)	Tool Steel, Pre-Hardened Steel, Hardened Steel (≤45HRC)	Hardened Steel (≤55HRC)	Hardened Steel (>55HRC)	Austenitic Stainless Steel	Titanium Alloy, Heat Resistant Alloy	Copper Alloy	Aluminium Alloy
	○	◎					

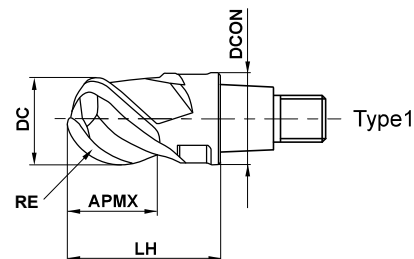

RE ≤ 6	RE > 6			
±0.010	±0.020			

- High efficiency machining is possible in deep applications (DCx5)
- High wear resistance and high chip evacuation is achieved when roughing.
- Effective vibration control enables high efficiency machining when finishing.

(mm)

Order Number	RE	DC	APMX	LH	DCON	Flutes	Grade	Type
							EP8120	
IMX10B3FV10008	5	10	8	16	9.7	3	★	1
IMX12B3FV12009	6	12	9.6	19	11.7	3	★	1
IMX16B3FV16012	8	16	12.8	24	15.5	3	★	1
IMX20B3FV20016	10	20	16	30	19.5	3	★	1

Note 1) The fastening size of the holder and head should be the same. (refer to Page J002.)

INDEXABLE HEAD END MILLS

SQUARE

BALL

RADIUS

TAPER

CHAMFER

ROUGHING

INDEXABLE HEAD END MILLS

IMX-B3FV

Ball nose head, For high efficiency machining, Irregular curve, 3 flute

RECOMMENDED CUTTING CONDITIONS

Shoulder milling (L/D=5)

Work material	P										H										
	Pre-hardened Steel, Alloy Tool Steel										Hardened Steel (40–55 HRC)										
	$\alpha \leq 15^\circ$				$\alpha > 15^\circ$				Depth of cut ap (mm)	Cutting Width ae (mm)	$\alpha \leq 15^\circ$				$\alpha > 15^\circ$				Depth of cut ap (mm)	Cutting Width ae (mm)	
Dia. DC (mm)	RE (mm)	Cutting Speed (m/min)	Main Spindle Revolution (min ⁻¹)	Feed per Tooth (mm/t)	Table Feed per Min. (mm/min)	Cutting Speed (m/min)	Main Spindle Revolution (min ⁻¹)	Feed per Tooth (mm/t)			Table Feed per Min. (mm/min)	Cutting Speed (m/min)	Main Spindle Revolution (min ⁻¹)	Feed per Tooth (mm/t)	Table Feed per Min. (mm/min)	Cutting Speed (m/min)	Main Spindle Revolution (min ⁻¹)	Feed per Tooth (mm/t)			Table Feed per Min. (mm/min)
10	5	175	5600	0.22	3700	115	3700	0.15	1700	0.7	2.6	150	4800	0.18	2600	100	3200	0.12	1200	0.5	2
12	6	175	4600	0.22	3000	115	3100	0.15	1400	1	3.2	150	4000	0.18	2200	100	2700	0.12	970	0.7	2.5
16	8	175	3500	0.22	2300	115	2300	0.15	1000	1.1	3.8	150	3000	0.18	1600	100	2000	0.12	720	0.9	3.5
20	10	175	2800	0.22	1800	115	1800	0.15	810	1.2	4.8	150	2400	0.18	1300	100	1600	0.12	580	1.1	4.2

INDEXABLE HEAD END MILLS

SQUARE

BALL

RADIUS

TAPER

CHAMFER

ROUGHING

Shoulder milling (L/D=7)

Work material	P										H										
	Pre-hardened Steel, Alloy Tool Steel										Hardened Steel (40–55 HRC)										
	$\alpha \leq 15^\circ$				$\alpha > 15^\circ$				Depth of cut ap (mm)	Cutting Width ae (mm)	$\alpha \leq 15^\circ$				$\alpha > 15^\circ$				Depth of cut ap (mm)	Cutting Width ae (mm)	
Dia. DC (mm)	RE (mm)	Cutting Speed (m/min)	Main Spindle Revolution (min ⁻¹)	Feed per Tooth (mm/t)	Table Feed per Min. (mm/min)	Cutting Speed (m/min)	Main Spindle Revolution (min ⁻¹)	Feed per Tooth (mm/t)			Table Feed per Min. (mm/min)	Cutting Speed (m/min)	Main Spindle Revolution (min ⁻¹)	Feed per Tooth (mm/t)	Table Feed per Min. (mm/min)	Cutting Speed (m/min)	Main Spindle Revolution (min ⁻¹)	Feed per Tooth (mm/t)			Table Feed per Min. (mm/min)
10	5	120	3800	0.2	2300	80	2500	0.13	980	0.5	1.3	100	3200	0.13	1200	65	2100	0.085	540	0.4	1
12	6	120	3200	0.2	1900	80	2100	0.13	820	0.7	1.6	100	2700	0.13	1100	65	1700	0.085	430	0.6	1.3
16	8	120	2400	0.2	1400	80	1600	0.13	620	0.8	1.9	100	2000	0.13	780	65	1300	0.085	330	0.7	1.8
20	10	120	1900	0.2	1100	80	1300	0.13	510	0.9	2.4	100	1600	0.13	620	65	1000	0.085	260	0.8	2.1

Note 1) If the depth of cut is shallow, the revolution and feed rate can be increased.

Note 2) The irregular helix flute end mill has a larger effect on controlling vibration when compared to standard end mills.

However, if the rigidity of the machine or the workpiece installation is poor, vibration or abnormal sound can occur.

In this case, please reduce the revolution and feed rate proportionately, or set a lower depth of cut.

Note 3) α is the inclination angle of the machined surface.

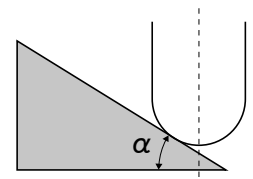

IMX-B4HV

Ball nose head, Irregular helix, 4 flute



Carbon Steel, Alloy Steel, Cast Iron (<30HRC)	Tool Steel, Pre-Hardened Steel, Hardened Steel (≤45HRC)	Hardened Steel (≤55HRC)	Hardened Steel (>55HRC)	Austenitic Stainless Steel	Titanium Alloy, Heat Resistant Alloy	Copper Alloy	Aluminium Alloy
○	○			○	○	○	

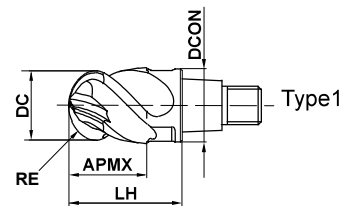

RE ≤ 6	RE > 6			
--------	--------	--	--	--

±0.010	±0.020			
--------	--------	--	--	--



DC ≤ 12	DC > 12			
---------	---------	--	--	--

0 - 0.020	0 - 0.030			
--------------	--------------	--	--	--

● Irregular helix cutting edge controls vibration and achieves stable machining of difficult-to-cut materials and is suitable for long overhang applications.

(mm)

Order Number	RE	DC	APMX	LH	DCON	Flutes	Grade	Type
							EP7020	
IMX10B4HV10010	5	10	10.5	16	9.7	4	●	1
IMX12B4HV12012	6	12	12.5	19	11.7	4	●	1
IMX16B4HV16016	8	16	16.5	24	15.5	4	●	1
IMX20B4HV20021	10	20	21	30	19.5	4	●	1
IMX25B4HV25026	12.5	25	26	37.5	24.5	4	●	1

Note 1) The fastening size of the holder and head should be the same. (refer to Page J002.)

INDEXABLE HEAD END MILLS

SQUARE

BALL

RADIUS

TAPER

CHAMFER

ROUGHING

● : Inventory maintained.

INDEXABLE HEAD END MILLS

IMX-B4HV-E

Ball nose head, Irregular curve, with coolant hole, 4 flute



Carbon Steel, Alloy Steel, Cast Iron (<30HRC)	Tool Steel, Pre-Hardened Steel, Hardened Steel (≤45HRC)	Hardened Steel (≤55HRC)	Hardened Steel (>55HRC)	Austenitic Stainless Steel	Titanium Alloy, Heat Resistant Alloy	Copper Alloy	Aluminium Alloy
○	○			○	○	○	

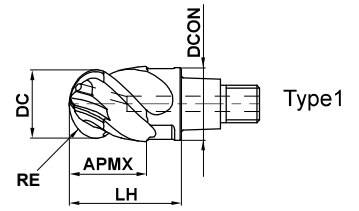

INDEXABLE HEAD END MILLS

SQUARE

BALL

RADIUS

TAPER

CHAMFER

ROUGHING

	RE ≤ 6	RE > 6			
	±0.010	±0.020			
	DC ≤ 12	DC > 12			
	0 - 0.020	0 - 0.030			

- Coolant holes for each cutting edge enable a stable coolant supply.
- Irregular helix cutting edge controls vibration and achieves stable machining of difficult-to-cut materials and is suitable for long overhang applications.

(mm)

Order Number	RE	DC	APMX	LH	DCON	Flutes	Grade	Type
							EP7020	
IMX10B4HV10010E	5	10	10.5	16	9.7	4	●	1
IMX12B4HV12012E	6	12	12.5	19	11.7	4	●	1
IMX16B4HV16016E	8	16	16.5	24	15.5	4	●	1
IMX20B4HV20021E	10	20	21	30	19.5	4	●	1
IMX25B4HV25026E	12.5	25	26	37.5	24.5	4	●	1

Note 1) The fastening size of the holder and head should be the same. (refer to Page J002.)

● : Inventory maintained.

IMX-B4HV/iMX-B4HV-E

Ball nose head, Irregular curve, With/Without coolant hole, 4 flute

RECOMMENDED CUTTING CONDITIONS

Shoulder milling (L/D=3)

Other than the L/D = 3, use following recommended cutting conditions by multiplying the J003 page correction factor of the overhang length.

Work material	P										N										M										S									
	Carbon steel, Alloy steel, Mild Steel, Pre-hardened steel, Copper, Copper alloys																				Austenitic stainless steel, Ferritic and martensitic stainless steel, Cobalt chromium alloy, Titanium alloy																			
	$\alpha \leq 15^\circ$					$\alpha > 15^\circ$					Depth of cut ap (mm)	Cutting Width ae (mm)	$\alpha \leq 15^\circ$					$\alpha > 15^\circ$					Depth of cut ap (mm)	Cutting Width ae (mm)																
Dia. DC (mm)	RE (mm)	Cutting Speed (m/min)	Main Spindle Revolution (min ⁻¹)	Feed per Tooth (mm/t)	Table Feed per Min. (mm/min)	Cutting Speed (m/min)	Main Spindle Revolution (min ⁻¹)	Feed per Tooth (mm/t)	Table Feed per Min. (mm/min)	Cutting Speed (m/min)			Main Spindle Revolution (min ⁻¹)	Feed per Tooth (mm/t)	Table Feed per Min. (mm/min)	Cutting Speed (m/min)	Main Spindle Revolution (min ⁻¹)	Feed per Tooth (mm/t)	Table Feed per Min. (mm/min)	Cutting Speed (m/min)	Main Spindle Revolution (min ⁻¹)	Feed per Tooth (mm/t)			Table Feed per Min. (mm/min)															
10 5		300	9500	0.106	4000	200	6400	0.07	1800	1	2.5	225	7200	0.105	3000	150	4800	0.067	1300	1	2.5																			
12 6		300	8000	0.125	4000	200	5300	0.085	1800	1.2	3	225	6000	0.125	3000	150	4000	0.08	1300	1.2	3																			
16 8		300	6000	0.134	3200	200	4000	0.088	1400	1.6	4	225	4500	0.14	2500	150	3000	0.09	1100	1.6	4																			
20 10		300	4800	0.156	3000	200	3200	0.1	1300	2	5	225	3600	0.16	2300	150	2400	0.105	1000	2	5																			
25 12.5		300	3800	0.16	2400	200	2500	0.1	1000	2.5	6	225	2900	0.16	1900	150	1900	0.105	800	2.5	6																			

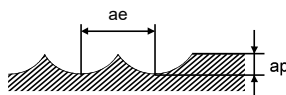

Work material	S																						
	Heat resistant alloys																						
	$\alpha \leq 15^\circ$					$\alpha > 15^\circ$					Depth of cut ap (mm)	Cutting Width ae (mm)	$\alpha \leq 15^\circ$					$\alpha > 15^\circ$					Depth of cut ap (mm)
Dia. DC (mm)	RE (mm)	Cutting Speed (m/min)	Main Spindle Revolution (min ⁻¹)	Feed per Tooth (mm/t)	Table Feed per Min. (mm/min)	Cutting Speed (m/min)	Main Spindle Revolution (min ⁻¹)	Feed per Tooth (mm/t)	Table Feed per Min. (mm/min)	Cutting Speed (m/min)			Main Spindle Revolution (min ⁻¹)	Feed per Tooth (mm/t)	Table Feed per Min. (mm/min)	Cutting Speed (m/min)	Main Spindle Revolution (min ⁻¹)	Feed per Tooth (mm/t)	Table Feed per Min. (mm/min)	Cutting Speed (m/min)	Main Spindle Revolution (min ⁻¹)	Feed per Tooth (mm/t)	
10 5		60	1900	0.055	420	40	1300	0.035	180	0.5	1												
12 6		60	1600	0.055	350	40	1100	0.035	150	0.6	1.2												
16 8		60	1200	0.062	300	40	800	0.04	130	0.8	1.6												
20 10		60	950	0.062	240	40	640	0.04	100	1	2												
25 12.5		60	760	0.062	190	40	510	0.04	82	1.2	2.5												

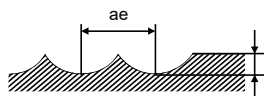

Note 1) For stainless steel, titanium and heat resistant alloys, the use of water-soluble coolant is effective.

Note 2) If the depth of cut is shallow, the revolution and feed rate can be increased.

Note 3) The irregular helix flute end mill has a large effect on controlling vibration when compared to standard end mills.

However, if the rigidity of the machine or the workpiece installation is poor, vibration or abnormal sound can occur.

In this case, please reduce the revolution and feed rate proportionately, or set a lower depth of cut.

Note 4) α is the inclination angle of the machined surface.

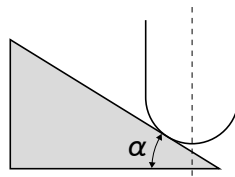

INDEXABLE HEAD END MILLS

SQUARE

BALL

RADIUS

TAPER

CHAMFER

ROUGHING

INDEXABLE HEAD END MILLS

IMX-B6HV

Ball nose head, Irregular helix, 6 flute



Carbon Steel, Alloy Steel, Cast Iron (<30HRC)	Tool Steel, Pre-Hardened Steel, Hardened Steel (<=45HRC)	Hardened Steel (<=55HRC)	Hardened Steel (>55HRC)	Austenitic Stainless Steel	Titanium Alloy, Heat Resistant Alloy	Copper Alloy	Aluminium Alloy
◎	○			◎	◎		

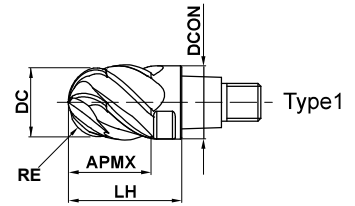

INDEXABLE HEAD END MILLS



RE ≤ 6	RE > 6			
--------	--------	--	--	--

±0.010	±0.020			
--------	--------	--	--	--



DC ≤ 12	DC > 12			
---------	---------	--	--	--

0	0			
- 0.020	- 0.030			

- Irregular helix cutting edge for vibration control and stable machining of difficult-to-cut materials.
- 6 flutes enable high machining efficiency.

(mm)

Order Number	RE	DC	APMX	LH	DCON	Flutes	Grade	Type
							EP7020	
IMX10B6HV10010	5	10	10.5	16	9.7	6	●	1
IMX12B6HV12012	6	12	12.5	19	11.7	6	●	1
IMX16B6HV16016	8	16	16.5	24	15.5	6	●	1
IMX20B6HV20021	10	20	21	30	19.5	6	●	1
IMX25B6HV25026	12.5	25	26	37.5	24.5	6	●	1

Note 1) The fastening size of the holder and head should be the same. (refer to Page J002.)

SQUARE

BALL

RADIUS

TAPER

CHAMFER

ROUGHING

● : Inventory maintained.

RECOMMENDED CUTTING CONDITIONS

■ Shoulder milling (L/D=3)

Other than the L/D = 3, use following recommended cutting conditions by multiplying the J003 page correction factor of the overhang length.

Work material	P										M				S						
	Carbon steel, Alloy steel, Mild Steel, Pre-hardened steel										Austenitic stainless steel, Ferritic and martensitic stainless steel, Cobalt chromium alloy, Titanium alloy										
	$\alpha \leq 15^\circ$				$\alpha > 15^\circ$				Depth of cut ap (mm)	Cutting Width ae (mm)	$\alpha \leq 15^\circ$				$\alpha > 15^\circ$				Depth of cut ap (mm)	Cutting Width ae (mm)	
Dia. DC (mm)	RE (mm)	Cutting Speed (m/min)	Main Spindle Revolution (min ⁻¹)	Feed per Tooth (mm/t)	Table Feed per Min. (mm/min)	Cutting Speed (m/min)	Main Spindle Revolution (min ⁻¹)	Feed per Tooth (mm/t)			Table Feed per Min. (mm/min)	Cutting Speed (m/min)	Main Spindle Revolution (min ⁻¹)	Feed per Tooth (mm/t)	Table Feed per Min. (mm/min)	Cutting Speed (m/min)	Main Spindle Revolution (min ⁻¹)	Feed per Tooth (mm/t)			Table Feed per Min. (mm/min)
10 5		300	9500	0.106	6000	200	6400	0.07	2700	0.5	2	225	7200	0.105	4500	150	4800	0.067	1900	0.5	2
12 6		300	8000	0.125	6000	200	5300	0.085	2700	0.6	2.4	225	6000	0.125	4500	150	4000	0.08	1900	0.6	2.4
16 8		300	6000	0.134	4800	200	4000	0.088	2100	0.8	3.2	225	4500	0.14	3800	150	3000	0.09	1600	0.8	3.2
20 10		300	4800	0.156	4500	200	3200	0.1	1900	1	4	225	3600	0.16	3500	150	2400	0.105	1500	1	4
25 12.5		300	3800	0.16	3600	200	2500	0.1	1500	1.2	5	225	2900	0.16	2800	150	1900	0.105	1200	1.2	5

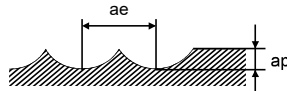

Work material	S																				
	Heat resistant alloys																				
	$\alpha \leq 15^\circ$				$\alpha > 15^\circ$				Depth of cut ap (mm)	Cutting Width ae (mm)	$\alpha \leq 15^\circ$				$\alpha > 15^\circ$				Depth of cut ap (mm)	Cutting Width ae (mm)	
Dia. DC (mm)	RE (mm)	Cutting Speed (m/min)	Main Spindle Revolution (min ⁻¹)	Feed per Tooth (mm/t)	Table Feed per Min. (mm/min)	Cutting Speed (m/min)	Main Spindle Revolution (min ⁻¹)	Feed per Tooth (mm/t)			Table Feed per Min. (mm/min)	Cutting Speed (m/min)	Main Spindle Revolution (min ⁻¹)	Feed per Tooth (mm/t)	Table Feed per Min. (mm/min)	Cutting Speed (m/min)	Main Spindle Revolution (min ⁻¹)	Feed per Tooth (mm/t)			Table Feed per Min. (mm/min)
10 5		60	1900	0.055	630	40	1300	0.035	270	0.5	1										
12 6		60	1600	0.055	530	40	1100	0.035	230	0.6	1.2										
16 8		60	1200	0.062	450	40	800	0.04	190	0.8	1.6										
20 10		60	950	0.062	350	40	640	0.04	150	1	2										
25 12.5		60	760	0.062	280	40	510	0.04	120	1.2	2.5										

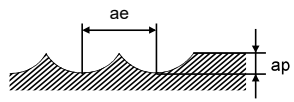

Note 1) For stainless steel, titanium and heat resistant alloys, the use of water-soluble coolant is effective.

Note 2) If the depth of cut is shallow, the revolution and feed rate can be increased.

Note 3) The irregular helix flute end mill has a large effect on controlling vibration when compared to standard end mills.

However, if the rigidity of the machine or the workpiece installation is poor, vibration or abnormal sound can occur.

In this case, please reduce the revolution and feed rate proportionately, or set a lower depth of cut.

Note 4) α is the inclination angle of the machined surface.

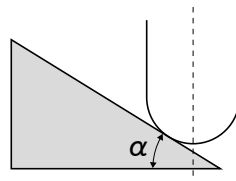

└

INDEXABLE HEAD END MILLS

SQUARE

BALL

RADIUS

TAPER

CHAMFER

ROUGHING

INDEXABLE HEAD END MILLS

IMX-B4WH-S NEW

Lollipop head, with coolant hole, 4 flute



Carbon Steel, Alloy Steel, Cast Iron (<30HRC)	Tool Steel, Pre-Hardened Steel, Hardened Steel (≤45HRC)	Hardened Steel (≤55HRC)	Hardened Steel (>55HRC)	Austenitic Stainless Steel	Titanium Alloy, Heat Resistant Alloy	Copper Alloy	Aluminium Alloy
◎	○			◎	◎	○	

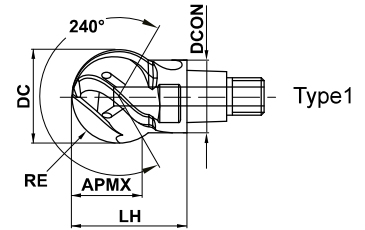

INDEXABLE HEAD END MILLS



RE ≥ 6				
±0.015				

- Optimal choice for machining undercut and complex shapes when using a 5-axis machine.
- A stable supply of coolant is maintained even when machining complex component geometries.

(mm)

Order Number	RE	DC	APMX	LH	DCON	Flutes	Grade	Type
							EP7020	
IMX10B4WH12008S	6	12	9	16.5	9.7	4	●	1
IMX12B4WH16008S	8	16	12	20.9	11.7	4	●	1
IMX16B4WH20008S	10	20	15	24.7	15.5	4	●	1

Note 1) The fastening size of the holder and head should be the same. (refer to Page J002.)

SQUARE

BALL

RADIUS

TAPER

CHAMFER

ROUGHING

● : Inventory maintained.

RECOMMENDED CUTTING CONDITIONS

Internal Profile Milling, Undercut Machining (L/D=3)

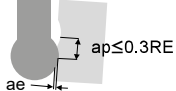
Work Material		P		N		M		S		S									
		Pre-hardened steel, Carbon steel, Alloy steel, Mild steel, Copper alloys										Austenitic stainless steel, Ferritic and martensitic stainless steels, Cobalt chromium alloy, Titanium alloy					Heat resistant alloys		
Dia. DC (mm)	RE (mm)	Cutting Speed (m/min)	Main Spindle Revolution (min ⁻¹)	Feed per Tooth (mm/t.)	Table Feed per Min. (mm/min)	Cutting Width ae (mm)	Cutting Speed (m/min)	Main Spindle Revolution (min ⁻¹)	Feed per Tooth (mm/t.)	Table Feed per Min. (mm/min)	Cutting Width ae (mm)	Cutting Speed (m/min)	Main Spindle Revolution (min ⁻¹)	Feed per Tooth (mm/t.)	Table Feed per Min. (mm/min)	Cutting Width ae (mm)			
12	6	100	2700	0.090	970	0.45	80	2100	0.075	630	0.45	30	800	0.040	130	0.36			
16	8	100	2000	0.100	800	0.60	80	1600	0.080	510	0.60	30	600	0.045	110	0.48			
20	10	100	1600	0.100	640	0.75	80	1300	0.090	470	0.75	30	480	0.050	96	0.60			
Depth of Cut																			

Internal Profile Milling, Undercut Machining (L/D=5)

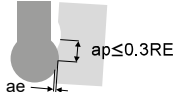
Work Material		P		N		M		S		S									
		Pre-hardened steel, Carbon steel, Alloy steel, Mild steel, Copper alloys										Austenitic stainless steel, Ferritic and martensitic stainless steels, Cobalt chromium alloy, Titanium alloy					Heat resistant alloys		
Dia. DC (mm)	RE (mm)	Cutting Speed (m/min)	Main Spindle Revolution (min ⁻¹)	Feed per Tooth (mm/t.)	Table Feed per Min. (mm/min)	Cutting Width ae (mm)	Cutting Speed (m/min)	Main Spindle Revolution (min ⁻¹)	Feed per Tooth (mm/t.)	Table Feed per Min. (mm/min)	Cutting Width ae (mm)	Cutting Speed (m/min)	Main Spindle Revolution (min ⁻¹)	Feed per Tooth (mm/t.)	Table Feed per Min. (mm/min)	Cutting Width ae (mm)			
12	6	70	1900	0.070	530	0.30	50	1300	0.050	260	0.30	20	530	0.030	64	0.24			
16	8	70	1400	0.080	450	0.40	50	990	0.060	240	0.40	20	400	0.040	64	0.32			
20	10	70	1100	0.080	350	0.50	50	800	0.070	220	0.50	20	320	0.040	51	0.40			
Depth of Cut																			

Internal Profile Milling, Undercut Machining (L/D=7)

Work Material		P		N		M		S								
		Pre-hardened steel, Carbon steel, Alloy steel, Mild steel, Copper alloys										Austenitic stainless steel, Ferritic and martensitic stainless steels, Cobalt chromium alloy, Titanium alloy				
Dia. DC (mm)	RE (mm)	Cutting Speed (m/min)	Main Spindle Revolution (min ⁻¹)	Feed per Tooth (mm/t.)	Table Feed per Min. (mm/min)	Cutting Width ae (mm)	Cutting Speed (m/min)	Main Spindle Revolution (min ⁻¹)	Feed per Tooth (mm/t.)	Table Feed per Min. (mm/min)	Cutting Width ae (mm)					
12	6	50	1300	0.030	160	0.15	30	800	0.025	80	0.15					
16	8	50	990	0.035	140	0.20	30	600	0.030	72	0.20					
20	10	50	800	0.040	130	0.25	30	480	0.035	67	0.25					
Depth of Cut																

Note 1) Vibration may occur if the rigidity of machine or workpiece material is low.

In this case, please reduce the revolution and the feed rate proportionately, or set a lower depth of cut.

Note 2) If the depth of cut is smaller, the revolution and the feed rate can be increased.

Note 3) In case of L/D > 5, It is recommended to use taper neck type holder.

Note 4) For stainless steels, titanium alloys and heat resistant alloys, the use of water-soluble coolant is effective.

INDEXABLE HEAD END MILLS

SQUARE

BALL

RADIUS

TAPER

CHAMFER

ROUGHING

INDEXABLE HEAD END MILLS

IMX-C4HV

Corner radius head, Irregular helix, 4 flute



Carbon Steel, Alloy Steel, Cast Iron (<30HRC)	Tool Steel, Pre-Hardened Steel, Hardened Steel (<=45HRC)	Hardened Steel (<=55HRC)	Hardened Steel (>55HRC)	Austenitic Stainless Steel	Titanium Alloy, Heat Resistant Alloy	Copper Alloy	Aluminium Alloy
○	○			○	○	○	

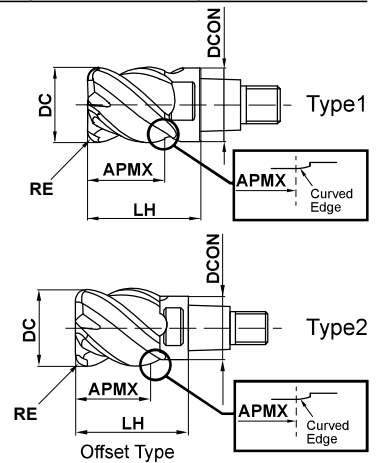

INDEXABLE HEAD END MILLS

RE				
±0.020				
DC ≤ 12	DC > 12			
0 - 0.020	0 - 0.030			

● Vibration control corner radius type achieves stable machining of difficult-to-cut materials and is suitable for long overhang applications due to the irregular helix.

(mm)

	Order Number	DC	RE	APMX	LH	DCON	Flutes	Grade	Type
								EP7020	
SQUARE	IMX10C4HV100R03010	10	0.3	10	16	9.7	4	●	1
	IMX10C4HV100R05010	10	0.5	10	16	9.7	4	●	1
	IMX10C4HV100R10010	10	1	10	16	9.7	4	●	1
	IMX10C4HV100R15010	10	1.5	10	16	9.7	4	●	1
BALL	IMX10C4HV100R20010	10	2	10	16	9.7	4	●	1
	IMX10C4HV100R25010	10	2.5	10	16	9.7	4	●	1
	IMX10C4HV100R30010	10	3	10	16	9.7	4	●	1
	IMX10C4HV110R05011	11	0.5	11.5	18	9.7	4	●	2
RADIUS	IMX10C4HV110R10011	11	1	11.5	18	9.7	4	★	2
	IMX10C4HV120R03012	12	0.3	12.5	19	9.7	4	●	2
	IMX10C4HV120R05012	12	0.5	12.5	19	9.7	4	●	2
	IMX10C4HV120R10012	12	1	12.5	19	9.7	4	●	2
	IMX10C4HV120R20012	12	2	12.5	19	9.7	4	●	2
	IMX12C4HV120R03012	12	0.3	12	19	11.7	4	●	1
	IMX12C4HV120R05012	12	0.5	12	19	11.7	4	●	1
	IMX12C4HV120R10012	12	1	12	19	11.7	4	●	1
	IMX12C4HV120R15012	12	1.5	12	19	11.7	4	●	1
	IMX12C4HV120R20012	12	2	12	19	11.7	4	●	1
	IMX12C4HV120R25012	12	2.5	12	19	11.7	4	●	1
	IMX12C4HV120R30012	12	3	12	19	11.7	4	●	1
CHAMFER	IMX12C4HV120R40012	12	4	12	19	11.7	4	●	1
	IMX12C4HV130R05013	13	0.5	13.5	21.5	11.7	4	★	2
	IMX12C4HV130R10013	13	1	13.5	21.5	11.7	4	★	2
	IMX12C4HV140R03014	14	0.3	14.5	22.5	11.7	4	●	2
ROUGHING	IMX12C4HV140R05014	14	0.5	14.5	22.5	11.7	4	●	2
	IMX12C4HV140R10014	14	1	14.5	22.5	11.7	4	●	2
	IMX12C4HV140R20014	14	2	14.5	22.5	11.7	4	●	2
	IMX16C4HV160R03016	16	0.3	16	24	15.5	4	●	1
	IMX16C4HV160R05016	16	0.5	16	24	15.5	4	●	1
	IMX16C4HV160R10016	16	1	16	24	15.5	4	●	1
	IMX16C4HV160R15016	16	1.5	16	24	15.5	4	●	1
	IMX16C4HV160R20016	16	2	16	24	15.5	4	●	1
IMX16C4HV160R25016	16	2.5	16	24	15.5	4	●	1	
IMX16C4HV160R30016	16	3	16	24	15.5	4	●	1	

● : Inventory maintained. ★ : Inventory maintained in Japan.

(mm)

Order Number	DC	RE	APMX	LH	DCON	Flutes	Grade	Type
							EP7020	
IMX16C4HV160R40016	16	4	16	24	15.5	4	●	1
IMX16C4HV160R50016	16	5	16	24	15.5	4	●	1
IMX16C4HV170R05017	17	0.5	17	26	15.5	4	★	2
IMX16C4HV170R10017	17	1	17	26	15.5	4	★	2
IMX16C4HV180R03018	18	0.3	18	27	15.5	4	●	2
IMX16C4HV180R05018	18	0.5	18.5	27	15.5	4	●	2
IMX16C4HV180R10018	18	1	18.5	27	15.5	4	●	2
IMX16C4HV180R20018	18	2	18.5	27	15.5	4	●	2
IMX16C4HV180R30018	18	3	18.5	27	15.5	4	●	2
IMX20C4HV200R03020	20	0.3	20	30	19.5	4	●	1
IMX20C4HV200R05020	20	0.5	20	30	19.5	4	●	1
IMX20C4HV200R10020	20	1	20	30	19.5	4	●	1
IMX20C4HV200R15020	20	1.5	20	30	19.5	4	●	1
IMX20C4HV200R20020	20	2	20	30	19.5	4	●	1
IMX20C4HV200R25020	20	2.5	20	30	19.5	4	●	1
IMX20C4HV200R30020	20	3	20	30	19.5	4	●	1
IMX20C4HV200R40020	20	4	20	30	19.5	4	●	1
IMX20C4HV200R50020	20	5	20	30	19.5	4	●	1
IMX20C4HV200R60020	20	6	20	30	19.5	4	●	1
IMX20C4HV200R63520	20	6.35	20	30	19.5	4	●	1
IMX20C4HV220R05023	22	0.5	23	33	19.5	4	★	2
IMX20C4HV220R10023	22	1	23	33	19.5	4	●	2
IMX20C4HV220R20023	22	2	23	33	19.5	4	●	2
IMX20C4HV220R30023	22	3	23	33	19.5	4	●	2
IMX25C4HV250R10025	25	1	25	37.5	24.5	4	●	1
IMX25C4HV250R20025	25	2	25	37.5	24.5	4	●	1
IMX25C4HV250R30025	25	3	25	37.5	24.5	4	●	1
IMX25C4HV250R40025	25	4	25	37.5	24.5	4	●	1
IMX25C4HV250R50025	25	5	25	37.5	24.5	4	●	1
IMX25C4HV250R60025	25	6	25	37.5	24.5	4	●	1
IMX25C4HV250R63525	25	6.35	25	37.5	24.5	4	●	1
IMX25C4HV280R10029	28	1	29	41.5	24.5	4	●	2
IMX25C4HV280R30029	28	3	29	41.5	24.5	4	●	2

INDEXABLE HEAD END MILLS

SQUARE

BALL

RADIUS

TAPER

CHAMFER

ROUGHING

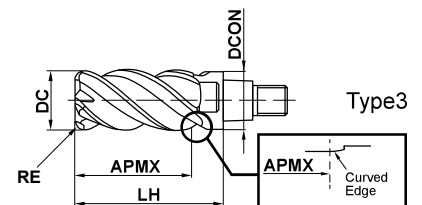

■ Long cutting edge type

(mm)

Order Number	DC	RE	APMX	LH	DCON	Flutes	Grade	Type
							EP7020	
IMX16C4HV160R10032	16	1	32	40	15.5	4	●	3
IMX16C4HV160R30032	16	3	32	40	15.5	4	●	3
IMX20C4HV200R10040	20	1	40	50	19.5	4	●	3
IMX20C4HV200R30040	20	3	40	50	19.5	4	●	3

Note 1) The fastening size of the holder and head should be the same. (refer to Page J002.)

INDEXABLE HEAD END MILLS

IMX-C4HV-S

Corner radius head, Irregular helix, with coolant hole, 4 flute



Carbon Steel, Alloy Steel, Cast Iron (<30HRC)	Tool Steel, Pre-Hardened Steel, Hardened Steel (<=45HRC)	Hardened Steel (<=55HRC)	Hardened Steel (>55HRC)	Austenitic Stainless Steel	Titanium Alloy, Heat Resistant Alloy	Copper Alloy	Aluminium Alloy
○	○			○	○	○	

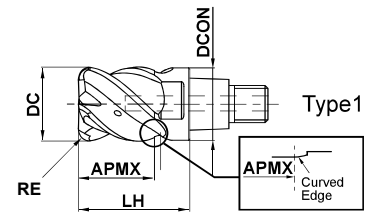

INDEXABLE HEAD END MILLS

RE				
±0.020				
DC ≤ 12	DC > 12			
0 - 0.020	0 - 0.030			

- Coolant holes for each cutting edge enable a stable coolant supply.
- Vibration control corner radius type for stable machining difficult-to-cut materials and long overhang applications due to the irregular helix.

(mm)

	Order Number	DC	RE	APMX	LH	DCON	Flutes	Grade	Type
								EP7020	
SQUARE	IMX10C4HV100R03010S	10	0.3	10	16	9.7	4	●	1
	IMX10C4HV100R05010S	10	0.5	10	16	9.7	4	●	1
	IMX10C4HV100R10010S	10	1	10	16	9.7	4	●	1
	IMX10C4HV100R15010S	10	1.5	10	16	9.7	4	●	1
BALL	IMX10C4HV100R20010S	10	2	10	16	9.7	4	●	1
	IMX10C4HV100R30010S	10	3	10	16	9.7	4	●	1
	IMX12C4HV120R03012S	12	0.3	12	19	11.7	4	●	1
	IMX12C4HV120R05012S	12	0.5	12	19	11.7	4	●	1
RADIUS	IMX12C4HV120R10012S	12	1	12	19	11.7	4	●	1
	IMX12C4HV120R15012S	12	1.5	12	19	11.7	4	●	1
	IMX12C4HV120R20012S	12	2	12	19	11.7	4	●	1
	IMX12C4HV120R30012S	12	3	12	19	11.7	4	●	1
	IMX12C4HV120R40012S	12	4	12	19	11.7	4	●	1
	IMX16C4HV160R05016S	16	0.5	16	24	15.5	4	●	1
	IMX16C4HV160R10016S	16	1	16	24	15.5	4	●	1
	IMX16C4HV160R15016S	16	1.5	16	24	15.5	4	●	1
TAPER	IMX16C4HV160R20016S	16	2	16	24	15.5	4	●	1
	IMX16C4HV160R30016S	16	3	16	24	15.5	4	●	1
	IMX16C4HV160R40016S	16	4	16	24	15.5	4	●	1
	IMX20C4HV200R05020S	20	0.5	20	30	19.5	4	●	1
CHAMFER	IMX20C4HV200R10020S	20	1	20	30	19.5	4	●	1
	IMX20C4HV200R15020S	20	1.5	20	30	19.5	4	●	1
	IMX20C4HV200R20020S	20	2	20	30	19.5	4	●	1
	IMX20C4HV200R30020S	20	3	20	30	19.5	4	●	1
ROUGHING	IMX20C4HV200R40020S	20	4	20	30	19.5	4	●	1
	IMX20C4HV200R60020S	20	6	20	30	19.5	4	●	1
	IMX20C4HV200R63520S	20	6.35	20	30	19.5	4	●	1
	IMX25C4HV250R10025S	25	1	25	37.5	24.5	4	●	1
	IMX25C4HV250R15025S	25	1.5	25	37.5	24.5	4	●	1
	IMX25C4HV250R20025S	25	2	25	37.5	24.5	4	●	1
	IMX25C4HV250R30025S	25	3	25	37.5	24.5	4	●	1
	IMX25C4HV250R40025S	25	4	25	37.5	24.5	4	●	1

Note 1) The fastening size of the holder and head should be the same. (refer to Page J002.)

● : Inventory maintained.

(mm)

Order Number	DC	RE	APMX	LH	DCON	Flutes	Grade	Type
							EP7020	
IMX25C4HV250R60025S	25	6	25	37.5	24.5	4	●	1
IMX25C4HV250R63525S	25	6.35	25	37.5	24.5	4	●	1

Note 1) The fastening size of the holder and head should be the same. (refer to Page J002.)



INDEXABLE HEAD END MILLS

SQUARE

BALL

RADIUS

TAPER

CHAMFER

ROUGHING

INDEXABLE HEAD END MILLS

IMX-C4HV/iMX-C4HV-S

Corner radius head, Irregular helix, With/Without coolant hole, 4 flute

RECOMMENDED CUTTING CONDITIONS

■ Shoulder milling (L/D=3)

Other than the L/D = 3, use following recommended cutting conditions by multiplying the J003 page correction factor of the overhang length.

Work material	P						N						P						M			S		
	Carbon steel, Alloy steel, Mild Steel, Copper, Copper alloys												Pre-hardened steel, Carbon steel, Alloy steel, Alloy tool steel						Austenitic stainless steel, Ferritic and martensitic stainless steel, Titanium alloy					
Dia. DC (mm)	Cutting Speed (m/min)	Main Spindle Revolution (min ⁻¹)	Feed per Tooth (mm/t)	Table Feed per Min. (mm/min)	Depth of Cut ap (mm)	Cutting Width ae (mm)	Cutting Speed (m/min)	Main Spindle Revolution (min ⁻¹)	Feed per Tooth (mm/t)	Table Feed per Min. (mm/min)	Depth of Cut ap (mm)	Cutting Width ae (mm)	Cutting Speed (m/min)	Main Spindle Revolution (min ⁻¹)	Feed per Tooth (mm/t)	Table Feed per Min. (mm/min)	Depth of Cut ap (mm)	Cutting Width ae (mm)						
10	150	4800	0.09	1700	10	2	120	3800	0.06	910	10	2	100	3200	0.075	960	10	2						
12	150	4000	0.09	1400	12	2.4	120	3200	0.065	830	12	2.4	100	2700	0.08	860	12	2.4						
16	150	3000	0.1	1200	16	3.2	120	2400	0.075	720	16	3.2	100	2000	0.09	720	16	3.2						
20	150	2400	0.1	960	20	4	120	1900	0.075	570	20	4	100	1600	0.09	580	20	4						
25	150	1900	0.12	910	25	5	120	1500	0.075	450	25	5	100	1300	0.09	470	25	5						

Depth of cut

Work material	M						S						S					
	Precipitation hardening stainless steel, Cobalt chromium alloy												Heat resistant alloys					
Dia. DC (mm)	Cutting Speed (m/min)	Main Spindle Revolution (min ⁻¹)	Feed per Tooth (mm/t)	Table Feed per Min. (mm/min)	Depth of Cut ap (mm)	Cutting Width ae (mm)	Cutting Speed (m/min)	Main Spindle Revolution (min ⁻¹)	Feed per Tooth (mm/t)	Table Feed per Min. (mm/min)	Depth of Cut ap (mm)	Cutting Width ae (mm)	Cutting Speed (m/min)	Main Spindle Revolution (min ⁻¹)	Feed per Tooth (mm/t)	Table Feed per Min. (mm/min)	Depth of Cut ap (mm)	Cutting Width ae (mm)
10	75	2400	0.06	580	10	2	40	1300	0.04	210	10	1	40	1300	0.04	210	10	1
12	75	2000	0.065	520	12	2.4	40	1100	0.045	200	12	1.2	40	1100	0.045	200	12	1.2
16	75	1500	0.075	450	16	3.2	40	800	0.05	160	16	1.6	40	800	0.05	160	16	1.6
20	75	1200	0.075	360	20	4	40	640	0.05	130	20	2	40	640	0.05	130	20	2
25	75	950	0.075	290	25	5	40	510	0.05	100	25	2.5	40	510	0.05	100	25	2.5

Depth of cut

Note 1) For stainless steel, titanium and heat resistant alloys, the use of water-soluble coolant is effective.

Note 2) If the depth of cut is shallow, the revolution and feed rate can be increased.

Note 3) The irregular helix flute end mill has a large effect on controlling vibration when compared to standard end mills.

However, if the rigidity of the machine or the workpiece installation is poor, vibration or abnormal sound can occur. In this case, please reduce the revolution and feed rate proportionately, or set a lower depth of cut.

INDEXABLE HEAD END MILLS

SQUARE

BALL

RADIUS

TAPER

CHAMFER

ROUGHING

Slot milling

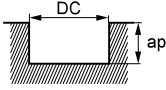
Work material	P					N					P					M					S																							
	Carbon steel, Alloy steel, Mild Steel, Copper, Copper alloys															Pre-hardened steel, Carbon steel, Alloy steel, Alloy tool steel															Austenitic stainless steel, Ferritic and martensitic stainless steel, Titanium alloy													
Dia. DC (mm)	Cutting speed (m/min)	Main Spindle Revolution (min ⁻¹)	Feed per Tooth (mm/t)	Table Feed per Min. (mm/min)	Depth of cut ap (mm)	Cutting speed (m/min)	Main Spindle Revolution (min ⁻¹)	Feed per Tooth (mm/t)	Table Feed per Min. (mm/min)	Depth of cut ap (mm)	Cutting speed (m/min)	Main Spindle Revolution (min ⁻¹)	Feed per Tooth (mm/t)	Table Feed per Min. (mm/min)	Depth of cut ap (mm)	Cutting speed (m/min)	Main Spindle Revolution (min ⁻¹)	Feed per Tooth (mm/t)	Table Feed per Min. (mm/min)	Depth of cut ap (mm)	Cutting speed (m/min)	Main Spindle Revolution (min ⁻¹)	Feed per Tooth (mm/t)	Table Feed per Min. (mm/min)	Depth of cut ap (mm)																			
10	100	3200	0.04	510	5	80	2500	0.03	300	5	75	2400	0.03	290	5	75	2400	0.03	290	5	75	2400	0.03	290	5																			
12	100	2700	0.05	540	6	80	2100	0.04	340	6	75	2000	0.04	320	6	75	2000	0.04	320	6	75	2000	0.04	320	6																			
16	100	2000	0.07	560	8	80	1600	0.05	320	8	75	1500	0.06	360	8	75	1500	0.06	360	8	75	1500	0.06	360	8																			
20	100	1600	0.07	450	10	80	1300	0.05	260	10	75	1200	0.06	290	10	75	1200	0.06	290	10	75	1200	0.06	290	10																			
25	100	1300	0.08	420	12	80	1000	0.05	200	12	75	950	0.06	230	12	75	950	0.06	230	12	75	950	0.06	230	12																			
Depth of cut																																												

DC: Dia.

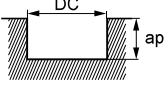
Work material	M					S					S																		
	Precipitation hardening stainless steel, Cobalt chromium alloy															Heat resistant alloys													
Dia. DC (mm)	Cutting speed (m/min)	Main Spindle Revolution (min ⁻¹)	Feed per Tooth (mm/t)	Table Feed per Min. (mm/min)	Depth of cut ap (mm)	Cutting speed (m/min)	Main Spindle Revolution (min ⁻¹)	Feed per Tooth (mm/t)	Table Feed per Min. (mm/min)	Depth of cut ap (mm)	Cutting speed (m/min)	Main Spindle Revolution (min ⁻¹)	Feed per Tooth (mm/t)	Table Feed per Min. (mm/min)	Depth of cut ap (mm)														
10	60	1900	0.025	190	5	30	950	0.02	76	2	30	950	0.02	76	2														
12	60	1600	0.035	220	6	30	800	0.03	96	2.4	30	800	0.03	96	2.4														
16	60	1200	0.05	240	8	30	600	0.05	120	3.2	30	600	0.05	120	3.2														
20	60	950	0.05	190	10	30	480	0.05	96	4	30	480	0.05	96	4														
25	60	760	0.05	150	12	30	380	0.05	76	5	30	380	0.05	76	5														
Depth of cut																													

DC: Dia.

Note 1) For stainless steel, titanium and heat resistant alloys, the use of water-soluble coolant is effective.

Note 2) If the depth of cut is shallow, the revolution and feed rate can be increased.

Note 3) The irregular helix flute end mill has a large effect on controlling vibration when compared to standard end mills.

However, if the rigidity of the machine or the workpiece installation is poor, vibration or abnormal sound can occur.

In this case, please reduce the revolution and feed rate proportionately, or set a lower depth of cut.



INDEXABLE HEAD END MILLS

SQUARE

BALL

RADIUS

TAPER

CHAMFER

ROUGHING

INDEXABLE HEAD END MILLS

IMX-C4HV

Corner radius head, Irregular helix, Long cutting edge type, 4 flute

RECOMMENDED CUTTING CONDITIONS

Shoulder milling

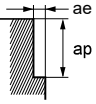
		P						N						P						M						S											
Work material		Carbon steel, Alloy steel, Mild Steel, Copper, Copper alloys												Pre-hardened steel, Carbon steel, Alloy steel, Alloy tool steel												Austenitic stainless steel, Ferritic and martensitic stainless steel, Titanium alloy											
L/D	Dia DC (mm)	Cutting Speed (m/min)	Main Spindle Revolution (min ⁻¹)	Feed per Tooth (mm/t)	Table Feed per Min. (mm/min)	Depth of Cut ap (mm)	Cutting Width ae (mm)	Cutting Speed (m/min)	Main Spindle Revolution (min ⁻¹)	Feed per Tooth (mm/t)	Table Feed per Min. (mm/min)	Depth of Cut ap (mm)	Cutting Width ae (mm)	Cutting Speed (m/min)	Main Spindle Revolution (min ⁻¹)	Feed per Tooth (mm/t)	Table Feed per Min. (mm/min)	Depth of Cut ap (mm)	Cutting Width ae (mm)	Cutting Speed (m/min)	Main Spindle Revolution (min ⁻¹)	Feed per Tooth (mm/t)	Table Feed per Min. (mm/min)	Depth of Cut ap (mm)	Cutting Width ae (mm)												
4	16	100	2000	0.09	720	32	0.8	80	1600	0.07	450	32	0.8	60	1200	0.08	380	32	0.8																		
	20	100	1600	0.09	580	40	1	80	1300	0.07	360	40	1	60	950	0.08	300	40	1																		
6	16	60	1200	0.07	340	32	0.8	50	990	0.05	200	32	0.8	40	800	0.06	190	32	0.8																		
	20	60	950	0.07	270	40	1	50	800	0.05	160	40	1	40	640	0.06	150	40	1																		
Depth of cut																																					

		M						S						S											
Work material		Precipitation hardening stainless steel, Cobalt chromium alloy												Heat resistant alloys											
L/D	Dia DC (mm)	Cutting Speed (m/min)	Main Spindle Revolution (min ⁻¹)	Feed per Tooth (mm/t)	Table Feed per Min. (mm/min)	Depth of Cut ap (mm)	Cutting Width ae (mm)	Cutting Speed (m/min)	Main Spindle Revolution (min ⁻¹)	Feed per Tooth (mm/t)	Table Feed per Min. (mm/min)	Depth of Cut ap (mm)	Cutting Width ae (mm)	Cutting Speed (m/min)	Main Spindle Revolution (min ⁻¹)	Feed per Tooth (mm/t)	Table Feed per Min. (mm/min)	Depth of Cut ap (mm)	Cutting Width ae (mm)	Cutting Speed (m/min)	Main Spindle Revolution (min ⁻¹)	Feed per Tooth (mm/t)	Table Feed per Min. (mm/min)	Depth of Cut ap (mm)	Cutting Width ae (mm)
4	16	50	990	0.07	280	32	0.8	30	600	0.05	120	32	0.4												
	20	50	800	0.07	220	40	1	30	480	0.05	96	40	0.5												
6	16	30	600	0.05	120	32	0.8	20	400	0.04	64	32	0.4												
	20	30	480	0.05	96	40	1	20	320	0.04	51	40	0.5												
Depth of cut																									

Note 1) For stainless steel, titanium and heat resistant alloys, the use of water-soluble coolant is effective.

Note 2) If the depth of cut is shallow, the revolution and feed rate can be increased.

Note 3) The irregular helix flute end mill has a large effect on controlling vibration when compared to standard end mills.

However, if the rigidity of the machine or the workpiece installation is poor, vibration or abnormal sound can occur.

In this case, please reduce the revolution and feed rate proportionately, or set a lower depth of cut.

Note 4) The length of the long cutting type is 2 times that of the standard head. L/D demonstrates +1 when installed to a holder of the same size.

INDEXABLE HEAD END MILLS

SQUARE

BALL

RADIUS

TAPER

CHAMFER

ROUGHING

IMX-C4HV

Corner radius head, Irregular helix, Offset type, 4 flute

RECOMMENDED CUTTING CONDITIONS

Shoulder milling

L/D	Dia DC (mm)	P					N					P					M					S				
		Cutting Speed (m/min)	Main Spindle Revolution (min ⁻¹)	Feed per Tooth (mm/t)	Table Feed per Min. (mm/min)	Depth of Cut ap (mm)	Cutting Width ae (mm)	Cutting Speed (m/min)	Main Spindle Revolution (min ⁻¹)	Feed per Tooth (mm/t)	Table Feed per Min. (mm/min)	Depth of Cut ap (mm)	Cutting Width ae (mm)	Cutting Speed (m/min)	Main Spindle Revolution (min ⁻¹)	Feed per Tooth (mm/t)	Table Feed per Min. (mm/min)	Depth of Cut ap (mm)	Cutting Width ae (mm)	Cutting Speed (m/min)	Main Spindle Revolution (min ⁻¹)	Feed per Tooth (mm/t)	Table Feed per Min. (mm/min)	Depth of Cut ap (mm)	Cutting Width ae (mm)	
3	11	150	4300	0.09	1500	11	1.1	120	3500	0.06	840	11	1.1	100	2900	0.075	870	11	1.1	100	2900	0.075	870	11	1.1	
	12	150	4000	0.09	1400	12	1.2	120	3200	0.06	770	12	1.2	100	2700	0.075	810	12	1.2	100	2700	0.075	810	12	1.2	
	13	150	3700	0.09	1300	13	1.3	120	2900	0.065	750	13	1.3	100	2400	0.08	770	13	1.3	100	2400	0.08	770	13	1.3	
	14	150	3400	0.09	1200	14	1.4	120	2700	0.065	700	14	1.4	100	2300	0.08	740	14	1.4	100	2300	0.08	740	14	1.4	
	17	150	2800	0.1	1100	17	1.7	120	2200	0.075	660	17	1.7	100	1900	0.08	610	17	1.7	100	1900	0.08	610	17	1.7	
	18	150	2700	0.1	1100	18	1.8	120	2100	0.075	630	18	1.8	100	1800	0.09	650	18	1.8	100	1800	0.09	650	18	1.8	
	22	150	2200	0.1	880	22	2.2	120	1700	0.075	510	22	2.2	100	1400	0.09	500	22	2.2	100	1400	0.09	500	22	2.2	
	28	150	1700	0.12	820	28	2.8	120	1400	0.075	420	28	2.8	100	1100	0.09	400	28	2.8	100	1100	0.09	400	28	2.8	
	30	150	1600	0.12	770	30	3	120	1300	0.075	390	30	3	100	1100	0.09	400	30	3	100	1100	0.09	400	30	3	
	32	150	1500	0.12	720	32	3.2	120	1200	0.075	360	32	3.2	100	990	0.09	360	32	3.2	100	990	0.09	360	32	3.2	
5	11	90	2600	0.07	730	11	0.4	70	2000	0.05	400	11	0.4	60	1700	0.06	410	11	0.4	60	1700	0.06	410	11	0.4	
	12	90	2400	0.07	670	12	0.5	70	1900	0.05	380	12	0.5	60	1600	0.06	380	12	0.5	60	1600	0.06	380	12	0.5	
	13	90	2200	0.07	620	13	0.5	70	1700	0.05	340	13	0.5	60	1500	0.06	360	13	0.5	60	1500	0.06	360	13	0.5	
	14	90	2000	0.07	560	14	0.6	70	1600	0.05	320	14	0.6	60	1400	0.06	340	14	0.6	60	1400	0.06	340	14	0.6	
	17	90	1700	0.08	540	17	0.7	70	1300	0.06	310	17	0.7	60	1100	0.07	310	17	0.7	60	1100	0.07	310	17	0.7	
	18	90	1600	0.08	510	18	0.7	70	1200	0.06	290	18	0.7	60	1100	0.07	310	18	0.7	60	1100	0.07	310	18	0.7	
	22	90	1300	0.08	420	22	0.9	70	1000	0.06	240	22	0.9	60	870	0.07	240	22	0.9	60	870	0.07	240	22	0.9	
	28	90	1000	0.1	400	28	1.1	70	800	0.06	190	28	1.1	60	680	0.07	190	28	1.1	60	680	0.07	190	28	1.1	
	30	90	950	0.1	380	30	1.2	70	740	0.06	180	30	1.2	60	640	0.07	180	30	1.2	60	640	0.07	180	30	1.2	
	32	90	900	0.1	360	32	1.3	70	700	0.06	170	32	1.3	60	600	0.07	170	32	1.3	60	600	0.07	170	32	1.3	
7	11	60	1700	0.06	410	11	0.2	50	1400	0.04	220	11	0.2	32	930	0.05	190	11	0.2	32	930	0.05	190	11	0.2	
	12	60	1600	0.06	380	12	0.2	50	1300	0.04	210	12	0.2	32	850	0.05	170	12	0.2	32	850	0.05	170	12	0.2	
	13	60	1500	0.06	360	13	0.3	50	1200	0.05	240	13	0.3	32	780	0.06	190	13	0.3	32	780	0.06	190	13	0.3	
	14	60	1400	0.06	340	14	0.3	50	1100	0.05	220	14	0.3	32	730	0.06	180	14	0.3	32	730	0.06	180	14	0.3	
	17	60	1100	0.07	310	17	0.3	50	940	0.05	190	17	0.3	32	600	0.06	140	17	0.3	32	600	0.06	140	17	0.3	
	18	60	1100	0.07	310	18	0.4	50	880	0.05	180	18	0.4	32	570	0.06	140	18	0.4	32	570	0.06	140	18	0.4	
	22	60	870	0.07	240	22	0.4	50	720	0.05	140	22	0.4	32	460	0.06	110	22	0.4	32	460	0.06	110	22	0.4	
	28	60	680	0.08	220	28	0.6	50	570	0.05	110	28	0.6	32	360	0.06	86	28	0.6	32	360	0.06	86	28	0.6	
	30	60	640	0.08	200	30	0.6	50	530	0.05	110	30	0.6	32	340	0.06	82	30	0.6	32	340	0.06	82	30	0.6	
	32	60	600	0.08	190	32	0.6	50	500	0.05	100	32	0.6	32	320	0.06	77	32	0.6	32	320	0.06	77	32	0.6	

The diagram illustrates the geometry of shoulder milling. It shows a cylindrical workpiece being machined by an end mill. The cutting width is labeled as 'ae' and the depth of cut is labeled as 'ap'. The end mill is shown in cross-section, with its cutting edges removing material from the top surface of the workpiece.

Note 1) For stainless steel, titanium and heat resistant alloys, the use of water-soluble coolant is effective.

Note 2) If the depth of cut is shallow, the revolution and feed rate can be increased.

Note 3) The irregular helix flute end mill has a large effect on controlling vibration when compared to standard end mills.

However, if the rigidity of the machine or the workpiece installation is poor, vibration or abnormal sound can occur.

In this case, please reduce the revolution and feed rate proportionately, or set a lower depth of cut.

INDEXABLE HEAD END MILLS

SQUARE

BALL

RADIUS

TAPER

CHAMFER

ROUGHING

INDEXABLE HEAD END MILLS

IMX-C4HV

Corner radius head, Irregular helix, Offset type, 4 flute

RECOMMENDED CUTTING CONDITIONS

Shoulder milling

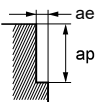
L/D	Dia DC (mm)	M		S			S						
		Cutting Speed (m/min)	Main Spindle Revolution (min ⁻¹)	Feed per Tooth (mm/t)	Table Feed per Min. (mm/min)	Depth of Cut ap (mm)	Cutting Width ae (mm)	Cutting Speed (m/min)	Main Spindle Revolution (min ⁻¹)	Feed per Tooth (mm/t)	Table Feed per Min. (mm/min)	Depth of Cut ap (mm)	Cutting Width ae (mm)
Work material		Precipitation hardening stainless steel, Cobalt chromium alloy						Heat resistant alloys					
3	11	75	2200	0.06	530	11	1.1	30	870	0.04	140	11	0.8
	12	75	2000	0.06	480	12	1.2	30	800	0.04	130	12	0.9
	13	75	1800	0.065	470	13	1.3	30	730	0.045	130	13	1
	14	75	1700	0.065	440	14	1.4	30	680	0.045	120	14	1.1
	17	75	1400	0.065	360	17	1.7	40	750	0.045	140	17	1.3
	18	75	1300	0.075	390	18	1.8	40	710	0.05	140	18	1.4
	22	75	1100	0.075	330	22	2.2	40	580	0.05	120	22	1.7
	28	75	850	0.075	260	28	2.8	40	450	0.05	90	28	2.1
	30	75	800	0.075	240	30	3	40	420	0.05	84	30	2.3
	32	75	750	0.075	230	32	3.2	40	400	0.05	80	32	2.4
5	11	50	1400	0.05	280	11	0.4	10	290	0.03	35	11	0.3
	12	50	1300	0.05	260	12	0.5	10	270	0.03	32	12	0.4
	13	50	1200	0.05	240	13	0.5	10	240	0.04	38	13	0.4
	14	50	1100	0.05	220	14	0.6	10	230	0.04	37	14	0.4
	17	50	940	0.06	230	17	0.7	19	360	0.04	58	17	0.5
	18	50	880	0.06	210	18	0.7	19	340	0.04	54	18	0.6
	22	50	720	0.06	170	22	0.9	19	270	0.04	43	22	0.7
	28	50	570	0.06	140	28	1.1	19	220	0.04	35	28	0.8
	30	50	530	0.06	130	30	1.2	19	200	0.04	32	30	0.9
	32	50	500	0.06	120	32	1.3	19	190	0.04	30	32	1
7	11	24	690	0.04	110	11	0.2	-	-	-	-	-	-
	12	24	640	0.04	100	12	0.2	-	-	-	-	-	-
	13	24	590	0.05	120	13	0.3	-	-	-	-	-	-
	14	24	550	0.05	110	14	0.3	-	-	-	-	-	-
	17	24	450	0.05	90	17	0.3	-	-	-	-	-	-
	18	24	420	0.05	84	18	0.4	-	-	-	-	-	-
	22	24	350	0.05	70	22	0.4	-	-	-	-	-	-
	28	24	270	0.05	54	28	0.6	-	-	-	-	-	-
	30	24	250	0.05	50	30	0.6	-	-	-	-	-	-
	32	24	240	0.05	48	32	0.6	-	-	-	-	-	-
Depth of cut													

Note 1) For stainless steel, titanium and heat resistant alloys, the use of water-soluble coolant is effective.

Note 2) If the depth of cut is shallow, the revolution and feed rate can be increased.

Note 3) The irregular helix flute end mill has a large effect on controlling vibration when compared to standard end mills.

However, if the rigidity of the machine or the workpiece installation is poor, vibration or abnormal sound can occur.

In this case, please reduce the revolution and feed rate proportionately, or set a lower depth of cut.

IMX-C6HV/C10HV/C12HV

Corner radius head, Irregular helix, Multi-fluted



DC ≤ 12

DC > 12

DC ≤ 12

DC > 12

Carbon Steel, Alloy Steel, Cast Iron (<30HRC)	Tool Steel, Pre-Hardened Steel, Hardened Steel (≤45HRC)	Hardened Steel (≤55HRC)	Hardened Steel (>55HRC)	Austenitic Stainless Steel	Titanium Alloy, Heat Resistant Alloy	Copper Alloy	Aluminium Alloy
⊙	○			⊙	⊙		

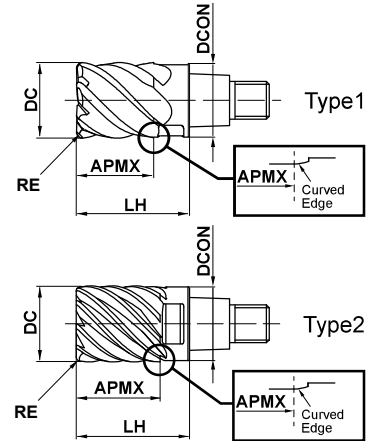

RE				
±0.020				



DC ≤ 12	DC > 12			
0 - 0.020	0 - 0.030			

- High machining efficiency due to multi-flute design.
- Irregular helix controls vibration and achieves stable machining.

(mm)

Order Number	DC	RE	APMX	LH	DCON	Flutes	Grade	Type
							EP7020	
IMX10C6HV100R05010	10	0.5	10	16	9.7	6	●	1
IMX10C6HV100R10010	10	1	10	16	9.7	6	●	1
IMX12C6HV120R10012	12	1	12	19	11.7	6	●	1
IMX16C10HV160R10016	16	1	16	24	15.5	10	●	2
IMX20C12HV200R10020	20	1	20	30	19.5	12	●	2
IMX25C12HV250R10025	25	1	25	37.5	24.5	12	●	2

Note 1) The fastening size of the holder and head should be the same. (refer to Page J002.)

● : Inventory maintained.



INDEXABLE HEAD END MILLS

SQUARE

BALL

RADIUS

TAPER

CHAMFER

ROUGHING

INDEXABLE HEAD END MILLS

IMX-C6HV/C10HV/C12HV

Corner radius head, Irregular helix, Multi-fluted

RECOMMENDED CUTTING CONDITIONS

■ Shoulder milling (L/D=3)

Other than the L/D = 3, use following recommended cutting conditions by multiplying the J003 page correction factor of the overhang length.

Work material	P						M						S					
	Pre-hardened steel, Carbon steel, Alloy steel, Alloy tool steel						Austenitic stainless steel, Ferritic and martensitic stainless steel, Titanium alloy						Precipitation hardening stainless steel, Cobalt chromium alloy					
Dia. DC (mm)	Cutting Speed (m/min)	Main Spindle Revolution (min ⁻¹)	Feed per Tooth (mm/t)	Table Feed per Min. (mm/min)	Depth of Cut ap (mm)	Cutting Width ae (mm)	Cutting Speed (m/min)	Main Spindle Revolution (min ⁻¹)	Feed per Tooth (mm/t)	Table Feed per Min. (mm/min)	Depth of Cut ap (mm)	Cutting Width ae (mm)	Cutting Speed (m/min)	Main Spindle Revolution (min ⁻¹)	Feed per Tooth (mm/t)	Table Feed per Min. (mm/min)	Depth of Cut ap (mm)	Cutting Width ae (mm)
10	200	6400	0.07	2700	10	1	150	4800	0.07	2000	10	1	100	3200	0.07	1300	10	1
12	200	5300	0.085	2700	12	1.2	150	4000	0.085	2000	12	1.2	100	2700	0.085	1400	12	1.2
16	200	4000	0.088	3500	16	0.6	150	3000	0.088	2600	16	0.64	100	2000	0.088	1800	16	0.6
20	200	3200	0.1	3800	20	0.8	150	2400	0.1	2900	20	0.8	100	1600	0.1	1900	20	0.8
25	200	2500	0.1	3000	25	1	150	1900	0.1	2300	25	1	100	1300	0.1	1600	25	1

Work material	S						
	Heat resistant alloys						
Dia. DC (mm)	Cutting Speed (m/min)	Main Spindle Revolution (min ⁻¹)	Feed per Tooth (mm/t)	Table Feed per Min. (mm/min)	Depth of Cut ap (mm)	Cutting Width ae (mm)	
10	40	1300	0.033	260	10	0.5	
12	40	1100	0.035	230	12	0.6	
16	40	800	0.038	300	16	0.6	
20	40	640	0.04	310	20	0.8	
25	40	510	0.04	240	25	1	

Note 1) For stainless steel, titanium and heat resistant alloys, the use of water-soluble coolant is effective.

Note 2) If the depth of cut is shallow, the revolution and feed rate can be increased.

Note 3) The irregular helix flute end mill has a large effect on controlling vibration when compared to standard end mills. However, if the rigidity of the machine or the workpiece installation is poor, vibration or abnormal sound can occur. In this case, please reduce the revolution and feed rate proportionately, or set a lower depth of cut.

Note 4) If the machining radius at the corner is the same as the tool radius when using a head with more than 10 flutes, please set the depth of cut and feed rate to half of the above.

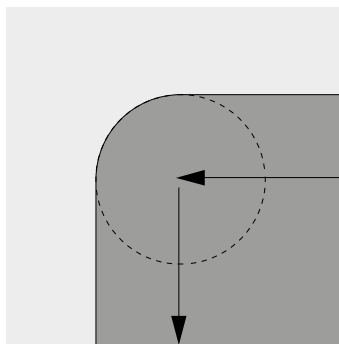

IMX-C4FD-C

Duplex corner radius head with coolant hole, For high feed, 4 flute



Carbon Steel, Alloy Steel, Cast Iron (<30HRC)	Tool Steel, Pre-Hardened Steel, Hardened Steel (≤45HRC)	Hardened Steel (≤55HRC)	Hardened Steel (>55HRC)	Austenitic Stainless Steel	Titanium Alloy, Heat Resistant Alloy	Copper Alloy	Aluminium Alloy
○	○	○		○	○	○	

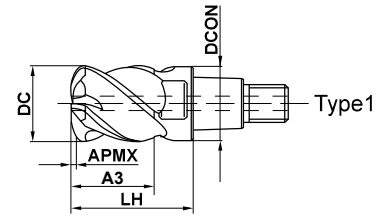

DC ≤ 12	DC > 12			
0	0			
-0.020	-0.030			

- The duplex corner radius and 4 flute geometry enable efficient machining at higher feed rates.
- End face centre coolant hole provides a stable supply of coolant.

Order Number	DC	RE1 ^{*1}	APMX	A3	LH	DCON	Flutes	RMPX ^{*2}	Grade	Type
									EP7020	
IMX10C4FD10010C	10	1.99	0.7	10.5	16	9.7	4	2.1°	●	1
IMX12C4FD12012C	12	2.1	0.8	12.5	19	11.7	4	2.8°	●	1
IMX16C4FD16016C	16	2.75	1	16.5	24	15.5	4	3°	●	1
IMX20C4FD20021C	20	3.07	1.3	21	30	19.5	4	3.3°	●	1
IMX25C4FD25026C	25	4.21	1.6	26	37.5	24.5	4	4.5°	●	1

Note 1) The fastening size of the holder and head should be the same. (refer to Page J002.)

Note 2) Duplex corner radius end mill is not suitable for corner radius machining due to the possibility of leaving unmachined areas.

*1 RE : Approximate Radius
*2 RMPX : Max. Ramping Angle

Order Number	RE1 ^{*1}	Duplex corner radius			
		S10	DCIN	RE2	RE3
IMX10C4FD10010C	1.99	0.27	3.4	1.5	5
IMX12C4FD12012C	2.1	0.33	4.5	1.5	6
IMX16C4FD16016C	2.75	0.42	6.2	2	8
IMX20C4FD20021C	3.07	0.59	8	2	10
IMX25C4FD25026C	4.21	0.67	10	3	12

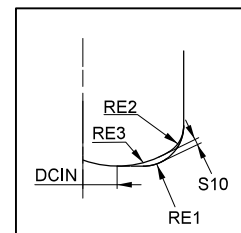

*Note for programming
Approximate Radius = RE1
Uncut portion = S10

● : Inventory maintained.

INDEXABLE HEAD END MILLS

SQUARE

BALL

RADIUS

TAPER

CHAMFER

ROUGHING

INDEXABLE HEAD END MILLS

IMX-C4FD-C

With coolant hole Multi-task corner radius end mill for high feed cutting

RECOMMENDED CUTTING CONDITIONS

■ Shoulder milling (L/D=3)

Other than the L/D = 3, use following recommended cutting conditions by multiplying the J003 page correction factor by overhang length.

Work material	P						N						P						H						M										
	Carbon steel, Alloy steel, Mild Steel, Copper, Copper alloys												Pre-hardened steel, Carbon steel, Alloy steel, Alloy tool steel												Hardened steel (45–55HRC), Precipitation hardening stainless steel, Ferritic and martensitic stainless steel										
Dia DC (mm)	Cutting Speed (m/min)	Main Spindle Revolution (min ⁻¹)	Feed per Tooth (mm/t)	Table Feed per Min. (mm/min)	Depth of Cut ap (mm)	Cutting Width ae (mm)	Cutting Speed (m/min)	Main Spindle Revolution (min ⁻¹)	Feed per Tooth (mm/t)	Table Feed per Min. (mm/min)	Depth of Cut ap (mm)	Cutting Width ae (mm)	Cutting Speed (m/min)	Main Spindle Revolution (min ⁻¹)	Feed per Tooth (mm/t)	Table Feed per Min. (mm/min)	Depth of Cut ap (mm)	Cutting Width ae (mm)	Cutting Speed (m/min)	Main Spindle Revolution (min ⁻¹)	Feed per Tooth (mm/t)	Table Feed per Min. (mm/min)	Depth of Cut ap (mm)	Cutting Width ae (mm)											
10	150	4800	0.4	7700	0.5	6	135	4300	0.4	6900	0.5	6	120	3800	0.3	4600	0.5	6	120	3800	0.3	4600	0.5	6											
12	150	4000	0.45	7200	0.6	7.2	135	3600	0.45	6500	0.6	7.2	120	3200	0.3	3800	0.6	7.2	120	3200	0.3	3800	0.6	7.2											
16	150	3000	0.5	6000	0.8	9.6	135	2700	0.5	5400	0.8	9.6	120	2400	0.4	3800	0.8	9.6	120	2400	0.4	3800	0.8	9.6											
20	150	2400	0.5	4800	1	12	135	2100	0.5	4200	1	12	120	1900	0.4	3000	1	12	120	1900	0.4	3000	1	12											
25	150	1900	0.5	3800	1.25	15	135	1700	0.5	3400	1.25	15	120	1500	0.4	2400	1.25	15	120	1500	0.4	2400	1.25	15											

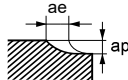
Depth of cut 

Work material	M						S						S											
	Austenitic stainless steel, Titanium alloy, Cobalt chromium alloy												Heat resistant alloys											
Dia DC (mm)	Cutting Speed (m/min)	Main Spindle Revolution (min ⁻¹)	Feed per Tooth (mm/t)	Table Feed per Min. (mm/min)	Depth of Cut ap (mm)	Cutting Width ae (mm)	Cutting Speed (m/min)	Main Spindle Revolution (min ⁻¹)	Feed per Tooth (mm/t)	Table Feed per Min. (mm/min)	Depth of Cut ap (mm)	Cutting Width ae (mm)	Cutting Speed (m/min)	Main Spindle Revolution (min ⁻¹)	Feed per Tooth (mm/t)	Table Feed per Min. (mm/min)	Depth of Cut ap (mm)	Cutting Width ae (mm)	Cutting Speed (m/min)	Main Spindle Revolution (min ⁻¹)	Feed per Tooth (mm/t)	Table Feed per Min. (mm/min)	Depth of Cut ap (mm)	Cutting Width ae (mm)
10	40	1300	0.2	1000	0.5	6	25	800	0.1	320	0.5	6	25	800	0.1	320	0.5	6	25	800	0.1	320	0.5	6
12	40	1100	0.2	880	0.6	7.2	25	660	0.1	260	0.6	7.2	25	660	0.1	260	0.6	7.2	25	660	0.1	260	0.6	7.2
16	40	800	0.3	960	0.8	9.6	25	500	0.15	300	0.8	9.6	25	500	0.15	300	0.8	9.6	25	500	0.15	300	0.8	9.6
20	40	640	0.3	770	1	12	25	400	0.15	240	1	12	25	400	0.15	240	1	12	25	400	0.15	240	1	12
25	40	510	0.3	610	1.25	15	25	320	0.15	190	1.25	15	25	320	0.15	190	1.25	15	25	320	0.15	190	1.25	15

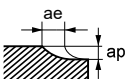
Depth of cut 

Note 1) For stainless steel, titanium and heat resistant alloys, the use of water-soluble coolant is effective.

Note 2) If the depth of cut is shallow, the revolution and feed rate can be increased.

Note 3) The irregular helix flute end mill has a large effect on controlling vibration when compared to standard end mills.

However, if the rigidity of the machine or the workpiece installation is poor, vibration or abnormal sound can occur.

In this case, please reduce the revolution and feed rate proportionately, or set a lower depth of cut.

Note 4) Reduce the feed by 1/2 for ramping process.

IMX-C4FV

Corner radius head for high efficiency machining, Irregular helix, 4 flute



Carbon Steel, Alloy Steel, Cast Iron (<30HRC)	Tool Steel, Pre-Hardened Steel, Hardened Steel (≤45HRC)	Hardened Steel (≤55HRC)	Hardened Steel (>55HRC)	Austenitic Stainless Steel	Titanium Alloy, Heat Resistant Alloy	Copper Alloy	Aluminium Alloy
---	---	-------------------------	-------------------------	----------------------------	--------------------------------------	--------------	-----------------

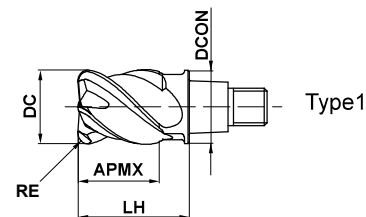

	RE ≤ 3	RE = 4			
	±0.010	±0.020			
	DC ≤ 12	DC > 12			
	0 - 0.020	0 - 0.030			

- Corner radius end mill for high efficiency machining
- Irregular helix controls vibration and achieves stable machining.

Order Number	DC	RE	APMX	LH	DCON	Flutes	Grade	Type
							EP6120	
IMX10C4FV100R20010	10	2	10.5	16	9.7	4	●	1
IMX12C4FV120R20012	12	2	12.5	19	11.7	4	●	1
IMX16C4FV160R30016	16	3	16.5	24	15.5	4	●	1
IMX20C4FV200R30021	20	3	21	30	19.5	4	●	1
IMX25C4FV250R40026	25	4	26	37.5	24.5	4	●	1

Note 1) The fastening size of the holder and head should be the same. (refer to Page J002.)

INDEXABLE HEAD END MILLS

SQUARE

BALL

RADIUS

TAPER

CHAMFER

ROUGHING

● : Inventory maintained.

INDEXABLE HEAD END MILLS

IMX-C4FV

Corner radius head for high efficiency machining, Irregular helix, 4 flute

RECOMMENDED CUTTING CONDITIONS

High depth of cut conditions

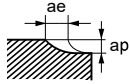
Work material		P												H					
		Carbon steel, Alloy steel, Gray Cast Iron						Pre-hardened steel, Alloy tool steel						Hardened steel (45—55HRC)					
Dia. DC (mm)	RE (mm)	Cutting Speed (m/min)	Main Spindle Revolution (min ⁻¹)	Feed per Tooth (mm/t)	Table Feed per Min. (mm/min)	Depth of Cut ap (mm)	Cutting Width ae (mm)	Cutting Speed (m/min)	Main Spindle Revolution (min ⁻¹)	Feed per Tooth (mm/t)	Table Feed per Min. (mm/min)	Depth of Cut ap (mm)	Cutting Width ae (mm)	Cutting Speed (m/min)	Main Spindle Revolution (min ⁻¹)	Feed per Tooth (mm/t)	Table Feed per Min. (mm/min)	Depth of Cut ap (mm)	Cutting Width ae (mm)
10	2	90	2900	0.25	2900	1.2	4.5	75	2400	0.23	2200	1	4.5	60	1900	0.22	1700	0.7	4.5
12	2	90	2400	0.25	2400	1.8	6	75	2000	0.23	1800	1.4	6	60	1600	0.22	1400	0.9	6
16	3	90	1800	0.25	1800	1.8	7.5	75	1500	0.23	1400	1.4	7.5	60	1200	0.22	1100	0.9	7.5
20	3	90	1400	0.25	1400	1.8	9	75	1200	0.23	1100	1.4	9	60	950	0.22	840	0.9	9
25	4	90	1100	0.25	1100	2.4	11.5	75	950	0.23	870	1.8	11.5	60	760	0.22	670	1.2	11.5
Depth of cut																			

INDEXABLE HEAD END MILLS

SQUARE

BALL

RADIUS

TAPER

CHAMFER

ROUGHING

High speed milling

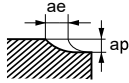
Work material		P												H					
		Carbon steel, Alloy steel, Gray Cast Iron						Pre-hardened steel, Alloy tool steel						Hardened steel (45—55HRC)					
Dia. DC (mm)	RE (mm)	Cutting Speed (m/min)	Main Spindle Revolution (min ⁻¹)	Feed per Tooth (mm/t)	Table Feed per Min. (mm/min)	Depth of Cut ap (mm)	Cutting Width ae (mm)	Cutting Speed (m/min)	Main Spindle Revolution (min ⁻¹)	Feed per Tooth (mm/t)	Table Feed per Min. (mm/min)	Depth of Cut ap (mm)	Cutting Width ae (mm)	Cutting Speed (m/min)	Main Spindle Revolution (min ⁻¹)	Feed per Tooth (mm/t)	Table Feed per Min. (mm/min)	Depth of Cut ap (mm)	Cutting Width ae (mm)
10	2	150	4800	0.4	7700	0.6	4.5	125	4000	0.35	5600	0.46	4.5	100	3200	0.3	3800	0.36	4.5
12	2	150	4000	0.45	7200	0.9	6	125	3300	0.4	5300	0.7	6	100	2700	0.3	3200	0.45	6
16	3	150	3000	0.5	6000	0.9	7.5	125	2500	0.45	4500	0.7	7.5	100	2000	0.3	2400	0.45	7.5
20	3	150	2400	0.5	4800	0.9	9	125	2000	0.45	3600	0.7	9	100	1600	0.35	2200	0.45	9
25	4	150	1900	0.5	3800	1.2	11.5	125	1600	0.45	2900	0.9	11.5	100	1300	0.35	1800	0.6	11.5
Depth of cut																			

Note 1) If the depth of cut is shallow, the revolution and feed rate can be increased.

Note 2) Air blow or oil mist is recommended for good chip evacuation.

Note 3) For profile machining such as moulds, machining conditions may differ considerably depending on the workpiece geometry, machining methods and depth of cut. Reduce the feed rate especially when machining the corner sections of a workpiece.

Note 4) The irregular helix flute end mill has a larger effect on controlling vibration when compared to standard end mills.

However, if the rigidity of the machine or the workpiece installation is poor, vibration or abnormal sound can occur.

In this case, please reduce the revolution and feed rate proportionately, or set a lower depth of cut.

IMX-C3A

Corner radius head, For aluminium alloy, 3 flute



Carbon Steel, Alloy Steel, Cast Iron (<30HRC)	Tool Steel, Pre-Hardened Steel, Hardened Steel (<=45HRC)	Hardened Steel (<=55HRC)	Hardened Steel (>55HRC)	Austenitic Stainless Steel	Titanium Alloy, Heat Resistant Alloy	Copper Alloy	Aluminium Alloy
---	--	--------------------------	-------------------------	----------------------------	--------------------------------------	--------------	-----------------

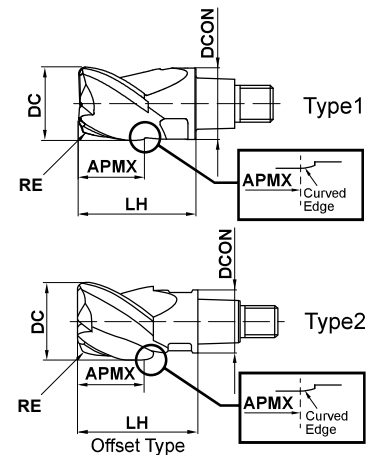

	RE				
	±0.020				
	DC ≤ 12	DC > 12			
	0 - 0.020	0 - 0.030			

● High efficiency machining is possible due to the polished rake face and sharp cutting edge.

(mm)

Order Number	DC	RE	APMX	LH	DCON	Flutes	Grade	Type
							ET2020	
IMX10C3A100R10008	10	1	8	16	9.7	3	●	1
IMX10C3A100R25008	10	2.5	8	16	9.7	3	●	1
IMX10C3A120R10010	12	1	10.1	19	9.7	3	●	2
IMX12C3A120R10009	12	1	9.6	19	11.7	3	●	1
IMX12C3A120R32009	12	3.2	9.6	19	11.7	3	●	1
IMX12C3A140R10011	14	1	11.7	22.5	11.7	3	●	2
IMX16C3A160R10012	16	1	12.8	24	15.5	3	●	1
IMX16C3A160R32012	16	3.2	12.8	24	15.5	3	●	1
IMX16C3A180R32014	18	3.2	14.9	27	15.5	3	●	2
IMX20C3A200R10016	20	1	16	30	19.5	3	●	1
IMX20C3A200R32016	20	3.2	16	30	19.5	3	●	1
IMX20C3A220R32018	22	3.2	18.6	33	19.5	3	●	2
IMX25C3A250R10020	25	1	20	37.5	24.5	3	●	1
IMX25C3A250R32020	25	3.2	20	37.5	24.5	3	●	1
IMX25C3A250R50020	25	5	20	37.5	24.5	3	●	1
IMX25C3A280R32023	28	3.2	23.4	41.5	24.5	3	●	2

Note 1) The fastening size of the holder and head should be the same. (refer to Page J002.)

INDEXABLE HEAD END MILLS

SQUARE

BALL

RADIUS

TAPER

CHAMFER

ROUGHING

● : Inventory maintained.

INDEXABLE HEAD END MILLS

IMX-C3A

Corner radius head, For aluminium alloy, 3 flute

RECOMMENDED CUTTING CONDITIONS

Shoulder milling (L/D=3)

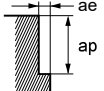
N						
Work Material	Aluminium alloy					
Dia. DC (mm)	Cutting Speed (m/min)	Main Spindle Revolution (min ⁻¹)	Feed per Tooth (mm/t)	Table Feed per Min. (mm/min)	Depth of Cut ap (mm)	Cutting Width ae (mm)
10	500	16000	0.117	5600	8	3
12	500	13000	0.118	4600	9.6	3.6
16	500	9900	0.153	4500	12.8	4.8
20	500	8000	0.175	4200	16	6
25	500	6400	0.211	4100	20	7.5
Depth of Cut						

Shoulder milling (L/D=5)

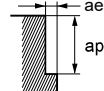
N						
Work Material	Aluminium alloy					
Dia. DC (mm)	Cutting Speed (m/min)	Main Spindle Revolution (min ⁻¹)	Feed per Tooth (mm/t)	Table Feed per Min. (mm/min)	Depth of Cut ap (mm)	Cutting Width ae (mm)
10	300	9500	0.09	2600	8	1.2
12	300	8000	0.09	2200	9.6	1.44
16	300	6000	0.12	2200	12.8	1.92
20	300	4800	0.14	2000	16	2.4
25	300	3800	0.17	1900	20	3
Depth of Cut						

Shoulder milling (L/D=7)

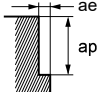
N						
Work Material	Aluminium alloy					
Dia. DC (mm)	Cutting Speed (m/min)	Main Spindle Revolution (min ⁻¹)	Feed per Tooth (mm/t)	Table Feed per Min. (mm/min)	Depth of Cut ap (mm)	Cutting Width ae (mm)
10	200	6400	0.08	1500	8	0.6
12	200	5300	0.08	1300	9.6	0.72
16	200	4000	0.11	1300	12.8	0.96
20	200	3200	0.12	1200	16	1.2
25	200	2500	0.15	1100	20	1.5
Depth of Cut						

Slot milling (L/D=3)

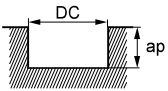
N					
Work Material	Aluminium alloy				
Dia. DC (mm)	Cutting Speed (m/min)	Main Spindle Revolution (min ⁻¹)	Feed per Tooth (mm/t)	Table Feed per Min. (mm/min)	Depth of Cut ap (mm)
10	500	16000	0.068	3300	5
12	500	13000	0.072	2800	6
16	500	9900	0.093	2800	8
20	500	8000	0.108	2600	10
25	500	6400	0.127	2400	12.5
Depth of Cut					

DC: Dia.

Plunging (L/D=3)

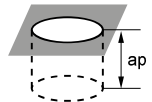
N						
Work Material	Aluminium alloy					
Dia. DC (mm)	Cutting Speed (m/min)	Main Spindle Revolution (min ⁻¹)	Feed per Revolution (mm/rev)	Table Feed per Min. (mm/min)	Drilled Depth ap (mm)	Step ap2 (mm)
10	300	9500	0.1	950	5	2.5
12	300	8000	0.1	800	6	2.5
16	300	6000	0.1	600	8	2.5
20	300	4800	0.1	480	10	2.5
25	300	3800	0.1	380	12.5	2.5
Depth of Cut						

Note 1) The use of water-soluble coolant is recommended.

Note 2) Vibration may occur if the rigidity of machine or workpiece is low. In this case, please reduce the revolution and feed rate proportionately, or set a lower depth of cut.

INDEXABLE HEAD END MILLS

SQUARE

BALL

RADIUS

TAPER

CHAMFER

ROUGHING

IMX-C3A

Corner radius head, For aluminium alloy, Offset type, 3 flute

RECOMMENDED CUTTING CONDITIONS

■ Shoulder milling

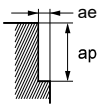
L/D		N					
		Aluminium alloy					
Dia. DC (mm)	Cutting Speed (m/min)	Main Spindle Revolution (min ⁻¹)	Feed per Tooth (mm/t)	Table Feed per Min. (mm/min)	Depth of Cut ap (mm)	Cutting Width ae (mm)	
3	12	500	13000	0.117	4600	9.6	2.4
	14	500	11000	0.118	3900	11.2	2.8
	18	500	8800	0.153	4000	14.4	3.6
	22	500	7200	0.175	3800	17.6	4.4
	28	500	5700	0.211	3600	22.4	5.6
5	12	300	8000	0.09	2200	9.6	1.0
	14	300	6800	0.09	1800	11.2	1.1
	18	300	5300	0.12	1900	14.4	1.4
	22	300	4300	0.14	1800	17.6	1.8
	28	300	3400	0.17	1700	22.4	2.2
Depth of cut							

Note 1) The use of water-soluble coolant is recommended.

Note 2) Vibration may occur if the rigidity of machine or workpiece is low.

In this case, please reduce the revolution and feed rate proportionately, or set a lower depth of cut.



INDEXABLE HEAD END MILLS

SQUARE

BALL

RADIUS

TAPER

CHAMFER

ROUGHING

INDEXABLE HEAD END MILLS

IMX-C8T/C10T/C12T/C15T-C

Corner radius, Taper head, with coolant hole, Multi-fluted



Carbon Steel, Alloy Steel, Cast Iron (<30HRC)	Tool Steel, Pre-Hardened Steel, Hardened Steel (<=45HRC)	Hardened Steel (<=55HRC)	Hardened Steel (>55HRC)	Austenitic Stainless Steel	Titanium Alloy, Heat Resistant Alloy	Copper Alloy	Aluminium Alloy
				⊙	⊙		

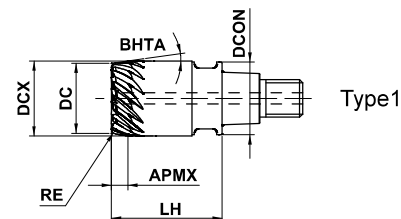

INDEXABLE HEAD END MILLS



RE				
±0.015				



DC ≤ 12	DC > 12			
0 - 0.020	0 - 0.030			

- Suitable for 3-dimensional free-form surface cutting such as blades.
- High feed cutting is possible due to multiple cutting edges and a wide chip pocket.

(mm)

Order Number	DC	RE	APMX	DCX	LH	DCON	BHTA	Flutes	Grade	Type
									EP7020	
IMX10C8T080R05T080C	8	0.5	7.12	10	16	9.7	8°	8	●	1
IMX10C8T080R10T080C	8	1	7.12	10	16	9.7	8°	8	●	1
IMX12C10T100R05T080C	10	0.5	7.12	12	19	11.7	8°	10	●	1
IMX12C10T100R10T080C	10	1	7.12	12	19	11.7	8°	10	●	1
IMX16C15T150R05T080C	15	0.5	3.56	16	24	15.5	8°	15	●	1
IMX16C15T150R10T080C	15	1	3.56	16	24	15.5	8°	15	●	1
IMX16C12T150R20T080C	15	2	3.56	16	24	15.5	8°	12	●	1
IMX20C15T190R05T080C	19	0.5	3.56	20	30	19.5	8°	15	●	1
IMX20C15T190R10T080C	19	1	3.56	20	30	19.5	8°	15	●	1
IMX20C12T190R20T080C	19	2	3.56	20	30	19.5	8°	12	●	1

Note 1) The fastening size of the holder and head should be the same. (refer to Page J002.)

SQUARE

BALL

RADIUS

TAPER

CHAMFER

ROUGHING

● : Inventory maintained.

RECOMMENDED CUTTING CONDITIONS

■ Shoulder milling (L/D=3)

Other than the L/D = 3, use following recommended cutting conditions by multiplying the J003 page correction factor of the overhang length.

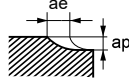
Work material		M						M				S		S					
		Austenitic stainless steel, Ferritic and martensitic stainless steel						Precipitation hardening stainless steel, Titanium alloy						Heat resistant alloys					
Dia. DC (mm)	No. of Flutes	Cutting Speed (m/min)	Main Spindle Revolution (min ⁻¹)	Feed per Tooth (mm/t)	Table Feed per Min. (mm/min)	Depth of Cut ap (mm)	Cutting Width ae (mm)	Cutting Speed (m/min)	Main Spindle Revolution (min ⁻¹)	Feed per Tooth (mm/t)	Table Feed per Min. (mm/min)	Depth of Cut ap (mm)	Cutting Width ae (mm)	Cutting Speed (m/min)	Main Spindle Revolution (min ⁻¹)	Feed per Tooth (mm/t)	Table Feed per Min. (mm/min)	Depth of Cut ap (mm)	Cutting Width ae (mm)
8	8	300	12000	0.1	9600	0.3	1.2	200	8000	0.1	6400	0.3	1.2	60	2400	0.08	1500	0.3	0.8
10	10	300	9500	0.1	9500	0.3	1.5	200	6400	0.1	6400	0.3	1.5	60	1900	0.08	1500	0.3	1
15	12	300	6400	0.12	9200	0.3	2.2	200	4200	0.12	6000	0.3	2.2	60	1300	0.1	1600	0.3	1.5
15	15	300	6400	0.1	9600	0.3	2.2	200	4200	0.1	6300	0.3	2.2	60	1300	0.08	1600	0.3	1.5
19	12	300	5000	0.12	7200	0.3	2.8	200	3400	0.12	4900	0.3	2.8	60	1000	0.1	1200	0.3	1.9
19	15	300	5000	0.1	7500	0.3	2.8	200	3400	0.1	5100	0.3	2.8	60	1000	0.08	1200	0.3	1.9
Depth of cut																			

Note 1) The use of water-soluble coolant is recommended.

Note 2) Vibration may occur if the rigidity of machine or workpiece is low.

In this case, please reduce the revolution and feed rate proportionately, or set a lower depth of cut.



INDEXABLE HEAD END MILLS

SQUARE

BALL

RADIUS

TAPER

CHAMFER

ROUGHING

INDEXABLE HEAD END MILLS

IMX-CH3L

Chamfer head, 3 flute



Carbon Steel, Alloy Steel, Cast Iron (<30HRC)	Tool Steel, Pre-Hardened Steel, Hardened Steel (<=45HRC)	Hardened Steel (<=55HRC)	Hardened Steel (>55HRC)	Austenitic Stainless Steel	Titanium Alloy, Heat Resistant Alloy	Copper Alloy	Aluminium Alloy
○	○	○		○	○		

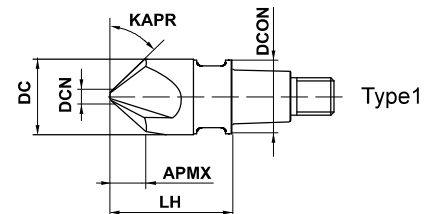

INDEXABLE HEAD END MILLS

SQUARE

BALL

RADIUS

TAPER

CHAMFER

ROUGHING

DCN=1.5				
±0.020				

- Chamfered cutting head suitable for inner circumference.
- Anti-vibration priority design.

(mm)

Order Number	DC	APMX	KAPR	DCN	LH	DCON	Flutes	Grade	Type
								EP7020	
IMX10CH3L100A45	10	4.2	45°	1.5	16	9.7	3	●	1
IMX12CH3L120A45	12	5.2	45°	1.5	19	11.7	3	●	1
IMX16CH3L160A45	16	7.2	45°	1.5	24	15.5	3	●	1
IMX20CH3L200A45	20	9.2	45°	1.5	30	19.5	3	●	1

Note 1) The fastening size of the holder and head should be the same. (refer to Page J002.)

RECOMMENDED CUTTING CONDITIONS

■ Chamfer milling (Hole circumference)

Work material		P												M				S			
		Carbon steel, Alloy steel, Gray Cast Iron												Alloy tool steel, Carbon steel, Alloy steel, Pre-hardened steel				Austenitic stainless steel, Titanium alloy			
Dia. DC (mm)	No. of Flutes	Cutting Speed (m/min)	Main Spindle Revolution (min ⁻¹)	Feed per Tooth (mm/t)	Table Feed per Min. (mm/min)	Depth of Cut ap (mm)	Cutting Width ae (mm)	Cutting Speed (m/min)	Main Spindle Revolution (min ⁻¹)	Feed per Tooth (mm/t)	Table Feed per Min. (mm/min)	Depth of Cut ap (mm)	Cutting Width ae (mm)	Cutting Speed (m/min)	Main Spindle Revolution (min ⁻¹)	Feed per Tooth (mm/t)	Table Feed per Min. (mm/min)	Depth of Cut ap (mm)	Cutting Width ae (mm)		
10	3	40	1300	0.04	160	1.8	1.8	40	1300	0.03	120	1.8	1.8	30	950	0.03	86	1.8	1.8		
12	3	40	1100	0.04	130	2.2	2.2	40	1100	0.03	99	2.2	2.2	30	800	0.03	72	2.2	2.2		
16	3	40	800	0.04	96	2.4	2.4	40	800	0.03	72	2.4	2.4	30	600	0.03	54	2.4	2.4		
20	3	40	640	0.04	77	2.6	2.6	40	640	0.03	58	2.6	2.6	30	480	0.03	43	2.6	2.6		

Depth of cut

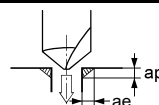

Note 1) For stainless steels, titanium alloy and heat resistant alloys, the use of water-soluble coolant is effective.

Note 2) Vibration may occur if the rigidity of machine or workpiece is low.

In this case, please reduce the revolution and feed rate proportionately.

● : Inventory maintained.

■ Chamfer milling (Hole circumference)

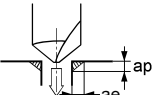
Work material		H						S					
		Hardened steel (40—55HRC)						Heat resistant alloys					
Dia. DC (mm)	No. of Flutes	Cutting Speed (m/min)	Main Spindle Revolution (min ⁻¹)	Feed per Tooth (mm/t)	Table Feed per Min. (mm/min)	Depth of Cut ap (mm)	Cutting Width ae (mm)	Cutting Speed (m/min)	Main Spindle Revolution (min ⁻¹)	Feed per Tooth (mm/t)	Table Feed per Min. (mm/min)	Depth of Cut ap (mm)	Cutting Width ae (mm)
10	3	30	950	0.02	57	1.8	1.8	30	950	0.04	110	1.8	1.8
12	3	30	800	0.02	48	2.2	2.2	30	800	0.04	96	2.2	2.2
16	3	30	600	0.02	36	2.4	2.4	30	600	0.04	72	2.4	2.4
20	3	30	480	0.02	29	2.6	2.6	30	480	0.04	58	2.6	2.6
Depth of cut													

■ Chamfer milling (Shape circumference)

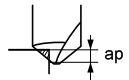
Work material		P										M		S		
		Carbon steel, Alloy steel, Gray Cast Iron						Alloy tool steel, Carbon steel, Alloy steel, Pre-hardened steel				Austenitic stainless steel, Titanium alloy				
Dia. DC (mm)	No. of Flutes	Cutting Speed (m/min)	Main Spindle Revolution (min ⁻¹)	Feed per Tooth (mm/t)	Table Feed per Min. (mm/min)	Depth of Cut ap (mm)	Cutting Speed (m/min)	Main Spindle Revolution (min ⁻¹)	Feed per Tooth (mm/t)	Table Feed per Min. (mm/min)	Depth of Cut ap (mm)	Cutting Speed (m/min)	Main Spindle Revolution (min ⁻¹)	Feed per Tooth (mm/t)	Table Feed per Min. (mm/min)	Depth of Cut ap (mm)
10	3	100	3200	0.05	480	2	70	2200	0.05	300	2	60	1900	0.04	230	2
12	3	100	2700	0.05	410	2.4	70	1900	0.05	260	2.4	60	1600	0.04	190	2.4
16	3	100	2000	0.05	300	2.7	70	1400	0.05	190	2.7	60	1200	0.04	140	2.7
20	3	100	1600	0.05	240	3.2	70	1100	0.05	150	3.2	60	950	0.04	110	3.2
Depth of Cut																

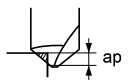
Work material		H					S				
		Hardened steel (40—55HRC)					Heat resistant alloys				
Dia. DC (mm)	No. of Flutes	Cutting Speed (m/min)	Main Spindle Revolution (min ⁻¹)	Feed per Tooth (mm/t)	Table Feed per Min. (mm/min)	Depth of Cut ap (mm)	Cutting Speed (m/min)	Main Spindle Revolution (min ⁻¹)	Feed per Tooth (mm/t)	Table Feed per Min. (mm/min)	Depth of Cut ap (mm)
10	3	50	1600	0.03	140	2	30	950	0.04	110	2
12	3	50	1300	0.03	120	2.4	30	800	0.04	96	2.4
16	3	50	990	0.03	89	2.7	30	600	0.04	72	2.7
20	3	50	800	0.03	72	3.2	30	480	0.04	58	3.2
Depth of Cut											

Note 1) For stainless steels, titanium alloy and heat resistant alloys, the use of water-soluble coolant is effective.

Note 2) Vibration may occur if the rigidity of machine or workpiece is low.

In this case, please reduce the revolution and feed rate proportionately.

INDEXABLE HEAD END MILLS

IMX-CH6V

Chamfer head, 6 flute



Carbon Steel, Alloy Steel, Cast Iron (<30HRC)	Tool Steel, Pre-Hardened Steel, Hardened Steel (≤45HRC)	Hardened Steel (≤55HRC)	Hardened Steel (>55HRC)	Austenitic Stainless Steel	Titanium Alloy, Heat Resistant Alloy	Copper Alloy	Aluminium Alloy
○	○	○		○	○		

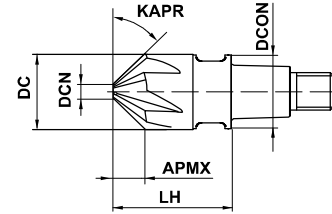

Type 1

INDEXABLE HEAD END MILLS

SQUARE

BALL

RADIUS

TAPER

CHAMFER

ROUGHING



DCN=3				
±0.020				

- Suitable for outer circumference.
- Multiple cutting design for priority of tool life.

(mm)

Order Number	DC	APMX	KAPR	DCN	LH	DCON	Flutes	Grade	Type
								EP7020	
IMX12CH6V120A45	12	4.5	45°	3	19	11.7	6	●	1
IMX16CH6V160A45	16	6.5	45°	3	24	15.5	6	●	1
IMX20CH6V200A45	20	8.5	45°	3	30	19.5	6	●	1

Note 1) The fastening size of the holder and head should be the same. (refer to Page J002.)

● : Inventory maintained.

RECOMMENDED CUTTING CONDITIONS

■ Chamfer milling (Shape circumference)

Work material		P						M		S						
		Carbon steel, Alloy steel, Gray Cast Iron						Alloy tool steel, Carbon steel, Alloy steel, Pre-hardened steel		Austenitic stainless steel, Titanium alloys						
Dia. DC (mm)	No. of Flutes	Cutting Speed (m/min)	Main Spindle Revolution (min ⁻¹)	Feed per Tooth (mm/t)	Table Feed per Min. (mm/min)	Depth of Cut ap (mm)	Cutting Speed (m/min)	Main Spindle Revolution (min ⁻¹)	Feed per Tooth (mm/t)	Table Feed per Min. (mm/min)	Depth of Cut ap (mm)	Cutting Speed (m/min)	Main Spindle Revolution (min ⁻¹)	Feed per Tooth (mm/t)	Table Feed per Min. (mm/min)	Depth of Cut ap (mm)
12	6	100	2700	0.05	810	2.4	70	1900	0.045	510	2.4	60	1600	0.04	380	2.4
16	6	100	2000	0.05	600	2.7	70	1400	0.045	380	2.7	60	1200	0.04	290	2.7
20	6	100	1600	0.05	480	3.2	70	1100	0.045	300	3.2	60	950	0.04	230	3.2

Depth of cut

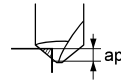

Work material		H					S				
		Hardened steel (40–55HRC)					Heat resistant alloys				
Dia. DC (mm)	No. of Flutes	Cutting Speed (m/min)	Main Spindle Revolution (min ⁻¹)	Feed per Tooth (mm/t)	Table Feed per Min. (mm/min)	Depth of Cut ap (mm)	Cutting Speed (m/min)	Main Spindle Revolution (min ⁻¹)	Feed per Tooth (mm/t)	Table Feed per Min. (mm/min)	Depth of Cut ap (mm)
12	6	50	1300	0.03	230	2.4	30	800	0.04	190	2.4
16	6	50	990	0.03	180	2.7	30	600	0.04	140	2.7
20	6	50	800	0.03	140	3.2	30	480	0.04	120	3.2

Depth of cut

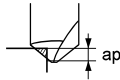

Note 1) The use of water-soluble coolant is recommended.

Note 2) Vibration may occur if the rigidity of machine or workpiece is low.

In this case, please reduce the revolution and feed rate proportionately.



INDEXABLE HEAD END MILLS

SQUARE

BALL

RADIUS

TAPER

CHAMFER

ROUGHING

INDEXABLE HEAD END MILLS

IMX

Carbide Holder

Undercut

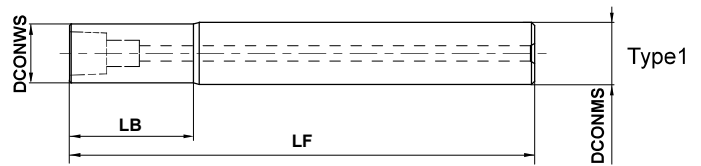

Straight

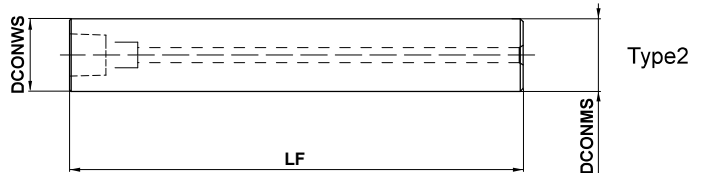

Taper neck type

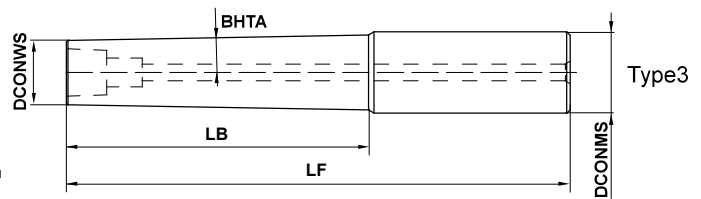

INDEXABLE HEAD END MILLS



DCONMS=10	12 ≤ DCONMS ≤ 16	20 ≤ DCONMS ≤ 25		
$\frac{0}{-0.009}$	$\frac{0}{-0.011}$	$\frac{0}{-0.013}$		

Carbide Holder

(mm)

Order Number	BHTA	LB	DCONWS	LF	DCONMS	Stock	Type	Suitable Head	Wrench
IMX10-U10N014L070C	—	14	9.7	70	10	●	1	IMX10	IMX10-WR
IMX10-S10L090C	—	—	10	90	10	●	2	IMX10	IMX10-WR
IMX10-U10N034L090C	—	34	9.7	90	10	●	1	IMX10	IMX10-WR
IMX10-S10L110C	—	—	10	110	10	●	2	IMX10	IMX10-WR
IMX10-U10N054L110C	—	54	9.7	110	10	●	1	IMX10	IMX10-WR
IMX10-A12N054L110C	1°	54	9.7	110	12	●	3	IMX10	IMX10-WR
IMX12-U12N017L080C	—	17	11.7	80	12	●	1	IMX12	IMX12-WR
IMX12-S12L100C	—	—	12	100	12	●	2	IMX12	IMX12-WR
IMX12-U12N041L100C	—	41	11.7	100	12	●	1	IMX12	IMX12-WR
IMX12-S12L130C	—	—	12	130	12	●	2	IMX12	IMX12-WR
IMX12-U12N065L130C	—	65	11.7	130	12	●	1	IMX12	IMX12-WR
IMX12-A16N065L130C	1°	65	11.7	130	16	●	3	IMX12	IMX12-WR
IMX16-U16N024L080C	—	24	15.5	80	16	●	1	IMX16	IMX16-WR
IMX16-S16L110C	—	—	16	110	16	●	2	IMX16	IMX16-WR
IMX16-U16N056L110C	—	56	15.5	110	16	●	1	IMX16	IMX16-WR
IMX16-S16L150C	—	—	16	150	16	●	2	IMX16	IMX16-WR
IMX16-U16N088L150C	—	88	15.5	150	16	●	1	IMX16	IMX16-WR
IMX16-A20N088L150C	1°	88	15.5	150	20	●	3	IMX16	IMX16-WR
IMX20-U20N030L090C	—	30	19.5	90	20	●	1	IMX20	IMX20-WR
IMX20-S20L130C	—	—	20	130	20	●	2	IMX20	IMX20-WR
IMX20-U20N070L130C	—	70	19.5	130	20	●	1	IMX20	IMX20-WR
IMX20-S20L180C	—	—	20	180	20	●	2	IMX20	IMX20-WR
IMX20-U20N110L180C	—	110	19.5	180	20	●	1	IMX20	IMX20-WR
IMX20-A25N110L180C	1°	110	19.5	180	25	●	3	IMX20	IMX20-WR
IMX25-U25N037L110C	—	37.5	24.5	110	25	●	1	IMX25	IMX25-WR
IMX25-S25L160C	—	—	25	160	25	●	2	IMX25	IMX25-WR
IMX25-U25N087L160C	—	87.5	24.5	160	25	●	1	IMX25	IMX25-WR
IMX25-S25L210C	—	—	25	210	25	●	2	IMX25	IMX25-WR

Note 1) The fastening size of the holder and head should be the same. (refer to Page J002.)

● : Inventory maintained.

IMX

Steel Holder

Undercut

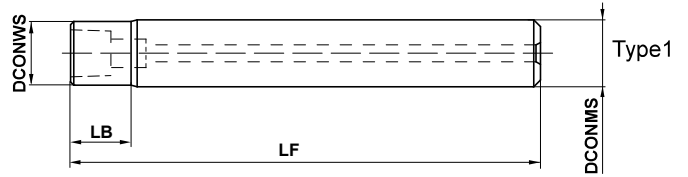

Straight

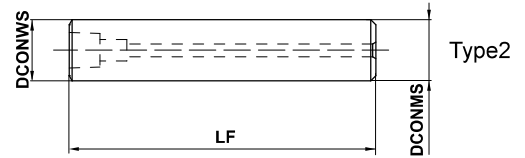

DCONMS=10	12 ≤ DCONMS ≤ 16	20 ≤ DCONMS ≤ 25	DCONMS=32
$\frac{0}{-0.009}$	$\frac{0}{-0.011}$	$\frac{0}{-0.013}$	$\frac{0}{-0.160}$

Steel Holder

(mm)

Order Number	LB	DCONWS	LF	DCONMS	Stock	Type	Suitable Head	Wrench
IMX10-U10N009L070S	9	9.7	70	10	●	1	IMX10	IMX10-WR
IMX10-G12L060S	—	12	60	12	●	2	IMX10	IMX10-WR
IMX12-U12N011L080S	11	11.7	80	12	●	1	IMX12	IMX12-WR
IMX12-G16L070S	—	16	70	16	●	2	IMX12	IMX12-WR
IMX16-U16N016L080S	16	15.5	80	16	●	1	IMX16	IMX16-WR
IMX16-G20L070S	—	20	70	20	●	2	IMX16	IMX16-WR
IMX20-U20N020L090S	20	19.5	90	20	●	1	IMX20	IMX20-WR
IMX20-G25L080S	—	25	80	25	●	2	IMX20	IMX20-WR
IMX25-U25N025L110S	25	24.5	110	25	●	1	IMX25	IMX25-WR
IMX25-G32L100S	—	32	100	32	●	2	IMX25	IMX25-WR

Note 1) The fastening size of the holder and head should be the same. (refer to Page J002.)

INDEXABLE HEAD END MILLS

HOW TO INSTALL THE HEAD

- 1 Using a clean cloth, wipe away oil and dust from the taper and end surfaces of the head and holder.

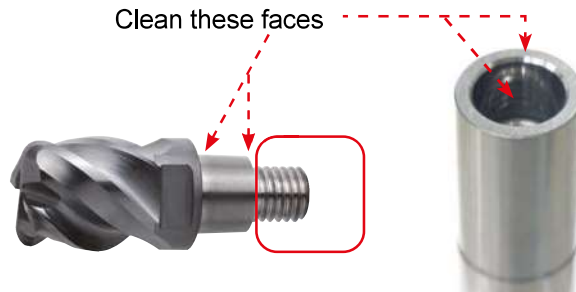

- 2 Be careful to avoid the possibility of injury when fastening with bare hands. Securely fasten the head and holder end surfaces using the enclosed wrench to close any remaining gap.

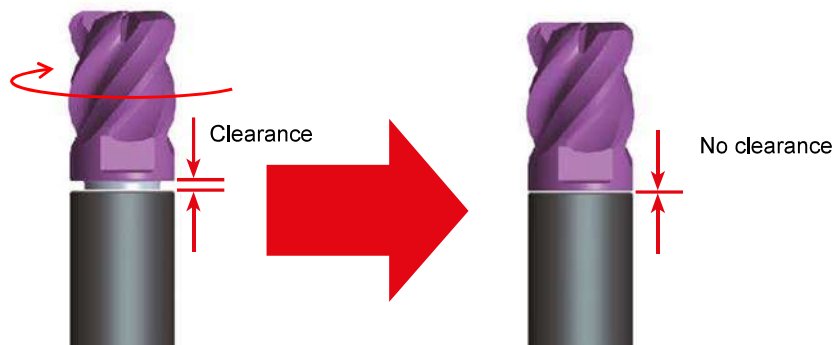

- 3 Refer to the table at below regarding angles for recommended torque when necessary. For precise usage, refer to the table below for torque wrench settings.

Suitable Head	Reference tightening angle α	Recommended clamping torque (Nm)
IMX10	50°	10
IMX12	50°	15
IMX16	50°	30
IMX20	40°	50
IMX25	35°	75

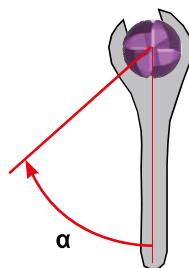

Note 1) Use the enclosed wrench only.
(Standard wrenches may be too thick)

HOW TO SELECT IMX HOLDERS

- When using straight holder + standard head, interference will occur in cases where the depth of cut is larger than the length of cut of the head.
- When using straight holder + offset head, larger depths of cut are possible because the diameter of the head is larger than the holder.

Straight + Standard head

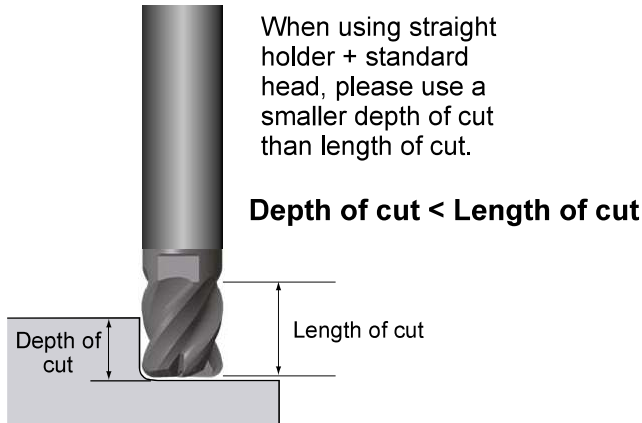

Less than $DC \times 3$ overhang is recommended when depth of cut < length of cut.

- Undercut type with relieved neck is suitable for vertical wall machining.
- The large diameter of the taper neck holder provides stability in long overhang applications.
- Undercut and taper neck types are now also available. (Please refer to diameter DC of each type for minimum diameter.)

Undercut + Standard head

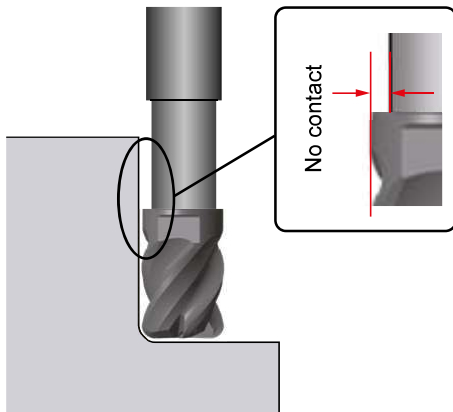

Straight + Offset head

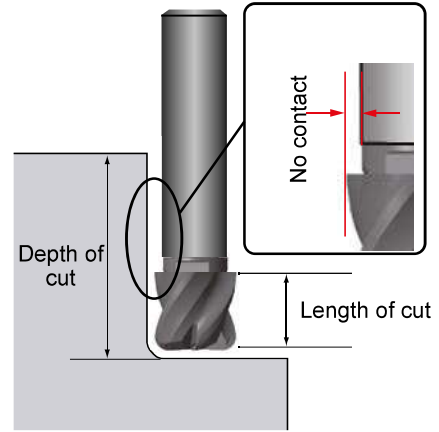

Taper neck + Standard head

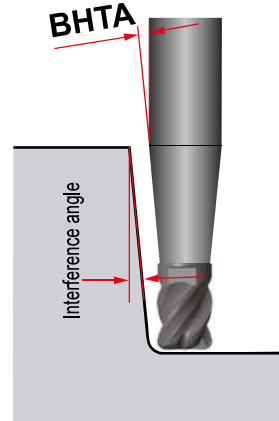

Memo

A series of horizontal dashed lines for writing, spanning the width of the page.

TECHNICAL DATA

ISO13399 COMPLIANCE	P002
FORMULAE FOR END MILLS	P006
TROUBLE SHOOTING FOR END MILLING	P008
END MILL FEATURES AND SPECIFICATIONS	P009
PITCH SELECTION OF PICK FEED	P011
METALLIC MATERIALS CROSS REFERENCE LIST	P012
SURFACE ROUGHNESS	P016
HARDNESS COMPARISON TABLE	P017
FIT TOLERANCE TABLE (HOLE).....	P018
FIT TOLERANCE TABLE (SHAFT).....	P020
INTERNATIONAL SYSTEM OF UNITS	P022



ISO13399 COMPLIANCE

List of Property Symbols Complying with ISO13399

Alphabetical

Source: ISO13399 standard

URL : <https://www.iso.org/search/x/query/13399>

TECHNICAL DATA

P

ISO13399 Property Symbols	Content
ADJLX	Adjustment limit maximum
ADJRG	Adjustment range
ALF	Clearance angle radial
ALP	Clearance angle axial
AN	Clearance angle major
ANN	Clearance angle minor
APMX	Depth of cut maximum
AS	Clearance angle wiper edge
ASP	Adjusting screw protrusion
AZ	Plunge depth maximum
B	Shank width
BBD	Balanced by design
BCH	Corner chamfer length
BD	Body diameter
BDX	Body diameter maximum
BHCC	Bolt hole circle count
BHTA	Body half taper angle
BMC	Body material code
BS	Wiper edge length
BSR	Wiper edge radius
CASC	Cartridge size code
CB	Chip breaker face count
CBDP	Connection bore depth
CBMD	Chip breaker manufacturers designation
CBP	Chip breaker property
CCMS	Connection code machine side
CCWS	Connection code workpiece side
CCP	Chamfer corner property
CDI	Insert cutting diameter
CDX	Cutting depth maximum
CEATC	Tool cutting edge angle type code
CECC	Cutting edge condition code
CEDC	Cutting edge count
CF	Spot chamfer
CHW	Corner chamfer width
CICT	Cutting item count
CNC	Corner count
CND	Coolant entry diameter
CNSC	Coolant entry style code
CNT	Coolant entry thread size
CP	Coolant pressure
CRE	Spot radius
CRKS	Connection retention knob thread size
CSP	Coolant supply property
CTP	Coating property
CTX	Cutting point translation X-direction
CTY	Cutting point translation Y-direction
CUTDIA	Work piece parting diameter maximum
CUB	Connection unit basis
CW	Cutting width
CWX	Cutting width maximum
CXD	Coolant exit diameter

ISO13399 Property Symbols	Content
CXSC	Coolant exit style code
CZC	Connection size code
D1	Fixing hole diameter
DAH	Diameter access hole
DAXN	Axial groove outside diameter minimum
DAXX	Axial groove outside diameter maximum
DBC	Diameter bolt circle
DC	Cutting diameter
DCB	Connection bore diameter
DCBN	Connection bore diameter minimum
DCBX	Connection bore diameter maximum
DCC	Design configuration style code
DCCB	Counterbore diameter connection bore
DCIN	Cutting diameter internal
DCINN	Cutting diameter internal minimum
DCINX	Cutting diameter internal maximum
DCN	Cutting diameter minimum
DCON	Connection diameter
DCONMS	Connection diameter machine side
DCONWS	Connection diameter workpiece side
DCSC	Cutting diameter size code
DCSFMS	Contact surface diameter machine side
DCX	Cutting diameter maximum
DF	Flange diameter
DHUB	Hub diameter
DMIN	Minimum bore diameter
DMM	Shank diameter
DN	Neck diameter
DRVA	Drive angle
EPSR	Insert included angle
FHA	Flute helix angle
FHCSA	Fixing hole countersunk angle
FHCSD	Fixing hole countersunk diameter
FLGT	Flange thickness
FMT	Form type
FXHLP	Fixing hole property
GAMF	Rake angle radial
GAMN	Rake angle normal
GAMO	Rake angle orthogonal
GAMP	Rake angle axial
GAN	Insert rake angle
H	Shank height
HA	Thread height theoretical
HAND	Hand
HBH	Head bottom offset height
HBKL	Head back offset length
HBKW	Head back offset width
HBL	Head bottom offset length
HC	Thread height actual
HF	Functional height
HHUB	Hub height
HTB	Body height
IC	Inscribed circle diameter
IFS	Insert mounting style code
IIC	Insert interface code
INSL	Insert length
KAPR	Tool cutting edge angle
KCH	Corner chamfer angle

TECHNICAL DATA

ISO13399 Property Symbols	Content
KRINS	Cutting edge angle major
KWW	Keyway width
KYP	Keyway property
L	Cutting edge length
LAMS	Inclination angle
LB	Body length
LBB	Chip breaker width
LBX	Body length maximum
LCCB	Counterbore depth connection bore
LCF	Length chip flute
LDRED	Reduced body diameter length
LE	Cutting edge effective length
LF	Functional length
LFA	a dimension on lf
LH	Head length
LPR	Protruding length
LS	Shank length
LSC	Clamping length
LSCN	Clamping length minimum
LSCX	Clamping length maximum
LTA	LTA length (length from MCS to CRP)
LU	Usable length
LUX	Usable length maximum
M	m-dimension
M2	Distance between the nominal inscribed circle and the corner of an insert that has the secondary included angle
MHA	Mounting hole angle
MHD	Mounting hole distance
MHH	Mounting hole height
MIID	Master insert identification
MTP	Clamping type code
NCE	Cutting end count
NOF	Flute count
NOI	Insert index count
NT	Tooth count
OAH	Overall height
OAL	Overall length
OAW	Overall width
PDPT	Profile depth insert
PDX	Profile distance ex
PDY	Profile distance ey
PFS	Profile style code
PL	Point length
PNA	Profile included angle
PRFRAD	Profile radius
PSIR	Tool lead angle
PSIRL	Cutting edge angle major left hand
PSIRR	Cutting edge angle major right hand
RAL	Relief angle left hand
RAR	Relief angle right hand
RCP	Rounded corner property
RE	Corner radius
REL	Corner radius left hand
RER	Corner radius right hand
RMPX	Ramping angle maximum
RPMX	Rotational speed maximum
S	Insert thickness
S1	Insert thickness total
SC	Insert shape code
SDL	Step diameter length
SIG	Point angle

ISO13399 Property Symbols	Content
SSC	Insert seat size code
SX	Shank cross section shape code
TC	Tolerance class insert
TCE	Tipped cutting edge code
TCTR	Thread tolerance class
TD	Thread diameter
THFT	Thread form type
THL	Threading length
THLGTH	Thread length
THSC	Tool holder shape code
THUB	Hub thickness
TP	Thread pitch
TPI	Threads per inch
TPIN	Threads per inch minimum
TPIX	Threads per inch maximum
TPN	Thread pitch minimum
TPT	Thread profile type
TPX	Thread pitch maximum
TQ	Torque
TSYC	Tool style code
TTP	Thread type
ULDR	Usable length diameter ratio
UST	Unit system
W1	Insert width
WEP	Wiper edge property
WF	Functional width
WF2	Distance between the cutting reference point and the front seating surface of a turning tool
WFS	Functional width secondary
WT	Weight of item
ZEFF	Face effective cutting edge count
ZEFP	Peripheral effective cutting edge count
ZNC	Cutting edge center count
ZNF	Face mounted insert count
ZNP	Peripheral mounted insert count

List of Reference Symbols Complying with ISO13399

ISO13399 Reference Symbols	Content
CIP	Coordinate system In Process
CRP	Cutting Reference Point
CSW	Coordinate System Workpiece side
MCS	Mounting Coordinate System
PCS	Primary Coordinate System

FORMULAE FOR END MILLS

TECHNICAL DATA

CUTTING SPEED (Vc)

$$V_c = \frac{\pi \cdot DC \cdot n}{1000} \text{ (m/min)}$$

Vc (m/min) : Cutting Speed
 π (3.14) : Pi

DC(mm) : Cutter Diameter
 n (min⁻¹) : Main Axis Spindle Speed

* Divide by 1000 to change to m from mm.

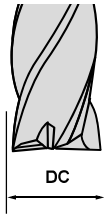

(Example) What is the cutting speed when the main axis spindle speed is 1900min⁻¹ and the cutter diameter is ϕ 20mm ?

(Answer) Substitute $\pi=3.14$, DC=20, n=1900 into the formula.

$$V_c = \frac{\pi \cdot DC \cdot n}{1000} = \frac{3.14 \cdot 20 \cdot 1900}{1000} = 120 \text{ m/min}$$

The cutting speed is 120m/min.

TABLE FEED (Vf)

$$V_f = f_z \cdot z \cdot n \text{ (mm/min)}$$

Vf (mm/min) : Table Feed per Min.
 fz (mm/t.) : Feed per Tooth
 n (min⁻¹) : Main Axis Spindle Speed

z : Number of flutes

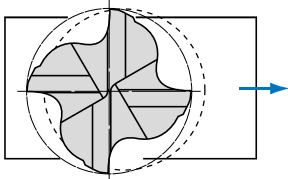

(Example) What is the table feed when feed per tooth is 0.07 mm/t, the number of flutes is 4, and the main axis spindle speed is 1900min⁻¹?

(Answer) Substitute the above figures into the formula.

$$V_f = f_z \cdot z \cdot n = 0.07 \cdot 4 \cdot 1900 = 540 \text{ mm/min}$$

The table feed is 540 mm/min.

CUTTING TIME (Tc)

$$T_c = \frac{L}{V_f} \text{ (min)}$$

Tc (min) : Cutting Time
 Vf (mm/min) : Table Feed per Min.
 L (mm) : Total Table Feed Length (Workpiece Length: I+Cutter Diameter:DC)

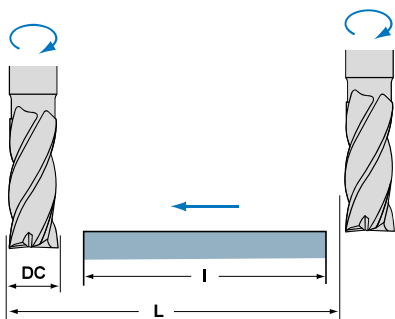

(Example) What is the cutting time required for slotting 20 mm width and 300 mm length surface of a cast iron (GG20) block when the cutter diameter is ϕ 20mm, the number of flutes is 4, the cutting speed is 120m/min, and feed per tooth is 0.07 mm/t. (spindle speed is 1900min⁻¹).

(Answer) Calculate table feed per min Vf=0.07•4• 1900= 540 mm/min
 Calculate total table feed length. L=300+20= 320 mm
 Substitute the above answers into the formula.

$$T_c = \frac{L}{V_f} = \frac{320}{540} = 0.592 \text{ m/min}$$

0.592•60= 35.5 (sec). The answer is 35.5 sec.

■ CUTTING POWER (Pc)

$$P_c = \frac{a_p \cdot a_e \cdot V_f \cdot K_c}{60 \times 10^6 \times \eta}$$

P_c (kW) : Actual Cutting Power
a_e (mm) : Cutting Width
K_c (MPa) : Specific Cutting Force

a_p (mm) : Depth of Cut
V_f (mm/min) : Table Feed per Min.
η : (Machine Coefficient)

(Example) What is the cutting power required for milling tool steel at a cutting speed of 80m/min. With depth of cut 2mm, cutting width 80mm, and table feed 280mm/min by ϕ 250 cutter with 12 inserts. Machine coefficient 80%.

(Answer) First, calculate the spindle speed in order to obtain the feed per tooth.

$$n = \frac{1000V_c}{\pi DC} = \frac{1000 \times 80}{3.14 \times 250} = 101.91 \text{ min}^{-1}$$

$$\text{Feed per Tooth } f_z = \frac{V_f}{z \times n} = \frac{280}{12 \times 101.9} = 0.228 \text{ mm/t.}$$

Substitute the specific cutting force into the formula.

$$P_c = \frac{2 \times 80 \times 280 \times 1800}{60 \times 10^6 \times 0.8} = 1.68 \text{ kW}$$

● K_c

Work Material	Tensile Strength (MPa) and Hardness	Specific Cutting Force K _c (MPa)				
		0.1mm/t.	0.2mm/t.	0.3mm/t.	0.4mm/t.	0.6mm/t.
Mild Steel	520	2200	1950	1820	1700	1580
Medium Steel	620	1980	1800	1730	1600	1570
Hard Steel	720	2520	2200	2040	1850	1740
Tool Steel	670	1980	1800	1730	1700	1600
Tool Steel	770	2030	1800	1750	1700	1580
Chrome Manganese Steel	770	2300	2000	1880	1750	1660
Chrome Manganese Steel	630	2750	2300	2060	1800	1780
Chrome Molybdenum Steel	730	2540	2250	2140	2000	1800
Chrome Molybdenum Steel	600	2180	2000	1860	1800	1670
Nickel Chrome Molybdenum Steel	940	2000	1800	1680	1600	1500
Nickel Chrome Molybdenum Steel	352HB	2100	1900	1760	1700	1530
Austenitic Stainless Steel	155HB	2030	1970	1900	1770	1710
Cast Iron	520	2800	2500	2320	2200	2040
Hard Cast Iron	46HRC	3000	2700	2500	2400	2200
Meehanite Cast Iron	360	2180	2000	1750	1600	1470
Grey Cast Iron	200HB	1750	1400	1240	1050	970
Brass	500	1150	950	800	700	630
Light Alloy (Al-Mg)	160	580	480	400	350	320
Light Alloy (Al-Si)	200	700	600	490	450	390
Light Alloy (Al-Zn-Mg-Cu)	570	880	840	840	810	720

TROUBLE SHOOTING FOR END MILLING



TECHNICAL DATA

Solution		Insert Grade Selection	Cutting Conditions									Style and Design of the Tool				Machine, Installation of Tool																																			
			Coated tool	Cutting speed		Feed	Depth of cut	Pick feed	Down cut	Use air blow	Coolant			Helix angle	Insert number	Concavity angle of end cutting edge	Tool diameter	Cutter rigidity	Wider chip pocket	Shorten tool overhang	Increase tool installation accuracy	Increase spindle collet run-out accuracy	Collet inspection and exchange	Increase chuck clamping power	Increase work clamping rigidity																										
				Up ↗	Down ↘	Up ↗	Down ↘				Increase coolant quantity	Do not use water-soluble cutting fluid	Determine dry or wet cutting													Up ↗ Larger	Down ↘ Smaller																								
Trouble	Factors																																																		
																									Deterioration of Tool Life	Large peripheral cutting edge wear	Non-coated end mill is used A small number of cutting edges Improper cutting conditions Up cut milling is used	●																							
																										Severe chipping	Improper cutting conditions Fragile cutting edge Insufficient clamping force Low clamping rigidity		↘																			●			
Breakage during cutting	Improper cutting conditions Low end mill rigidity Overhang longer than necessary Chip jamming				↘																																														
Deterioration of Surface Finish	Vibration during cutting	Improper cutting conditions Low end mill rigidity Low clamping rigidity		↘	↘																																														
	Poor surface finish on walls	Large cutting edge wear Improper cutting conditions Chip packing	●	↘		↘				●	●																																								
	Poor surface finish on faces	The end cutting edge does not have a concave angle Large pick feed				↘	↘																																												
	Out of vertical	Large cutting edge wear Improper cutting conditions Lack of end mill rigidity	●			↘	↘																																												
	Poor dimensional accuracy	Improper cutting conditions Low clamping rigidity		↘	↘	↘																																													
Burs, Chipping, etc.	Burr or chipping occurs	Improper cutting conditions Large helix angle			↘	↘																																													
	Quick bur formation	Notch wear Improper cutting conditions	●			↘																																													
Poor Chip Dispersal	Chip packing	Metal removal too large Lack of chip pocket				↘	↘																																												

END MILL FEATURES AND SPECIFICATIONS

■ NOMENCLATURE

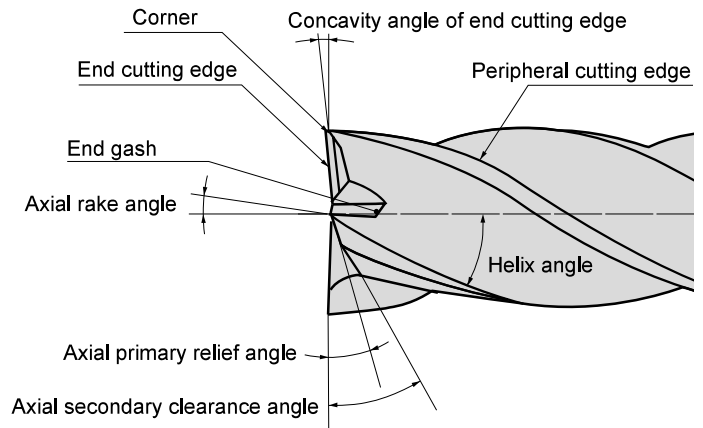
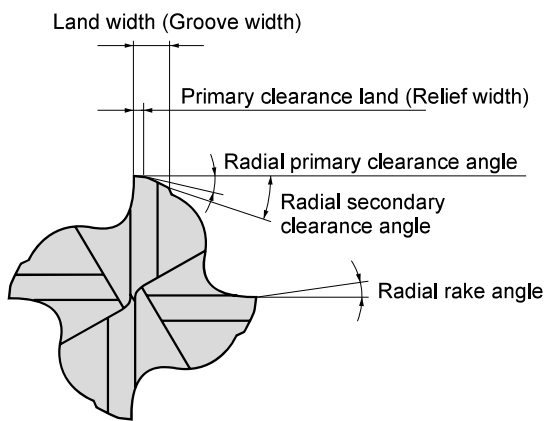
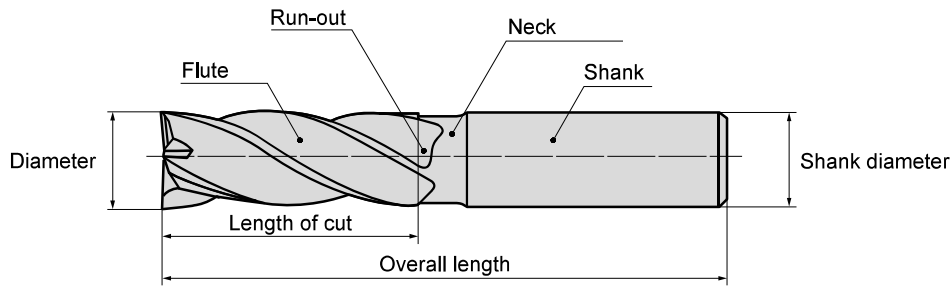

P

TECHNICAL DATA

■ COMPARISON OF SECTIONAL SHAPE AREA OF CHIP POCKET

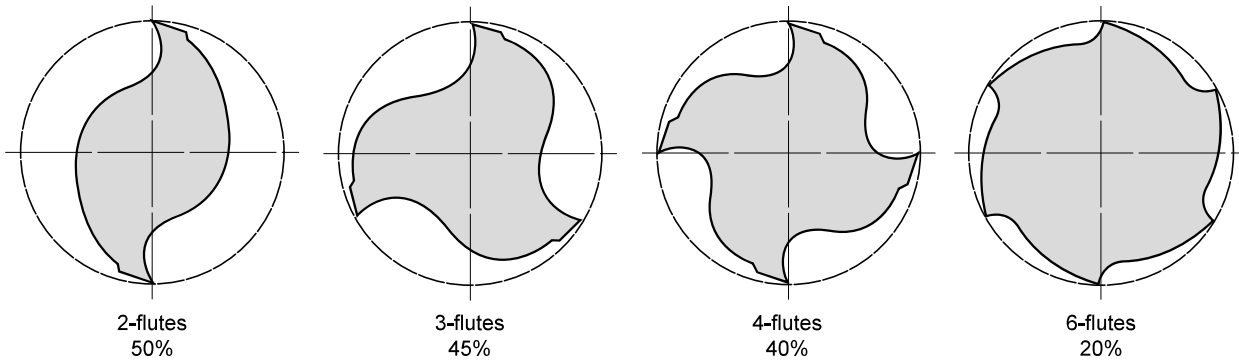

■ CHARACTERISTICS AND APPLICATIONS OF DIFFERENT-NUMBER-OF-FLUTE END MILLS

	2-flutes	3-flutes	4-flutes	6-flutes
Feature	Advantage	Chip disposability is excellent. Suitable for sinking. Drilling is easy.	Chip disposability is excellent. Suitable for sinking.	High rigidity. Superior cutting edge durability.
	Fault	Low rigidity	Diameter is not measured easily.	Chip disposability is poor.
Usage	Slotting, side milling, sinking. Wide range of use.	Slotting, side milling Heavy cutting, finishing	Shallow slotting, side milling Finishing	High Hardness Material Shallow slotting, side milling

END MILL FEATURES AND SPECIFICATION



P

TECHNICAL DATA

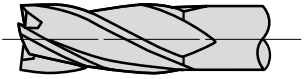
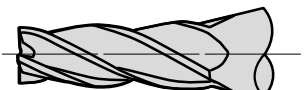
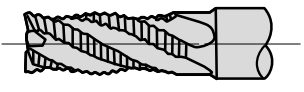
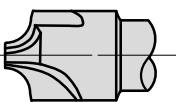

■ Peripheral Cutting Edge

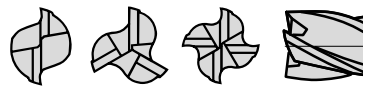
Type	Shape	Feature
Ordinary Flute		Regular flute geometry as shown is most commonly used for roughing and finishing of side milling, slotting and shoulder milling.
Tapered Flute		A tapered flute geometry is used for special applications such as mould drafts and for applying taper angles after conventional straight edged milling.
Roughing Flute		Roughing type geometry has a wave like edge form and breaks the material into small chips. Additionally the cutting resistance is low enabling high feed rates when roughing. The inside face of the flute is suitable for regrinding.
Formed Flute		Special form geometry as shown is used for producing corner radii on components. There are an infinite number of different geometries that can be manufactured using such style of cutters.

■ End Cutting Edge

Type	Shape	Feature
Square End (With Centre Hole)		Generally used for side milling, slotting and shoulder milling. Plunge cutting is not possible due to the centre hole that is used to ensure accurate grinding and regrinding of the tool.
Square End (Centre Cut)		Generally used for side milling, slotting and shoulder milling. Plunge cutting is possible and greater plunge cutting efficiency is obtained when using fewer flutes. Regrinding on the flank face can be done.
Ball End		Geometry completely suited for curved surface milling. At the extreme end point the chip pocket is very small leading to inefficient chip evacuation.
Corner Radius End		Used for radius profiling and corner radius milling. When pick feed milling an end mill with a large diameter and small corner radius can be used efficiently.

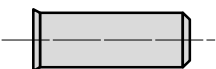
■ Shank And Neck Parts

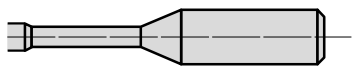
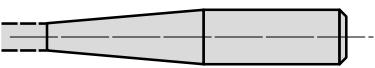
Type	Shape	Feature
Standard (Straight Shank)		Most widely used type.
Long Shank		Long shank type for deep pocket and shoulder applications.
Long Neck		Long neck geometry can be used for deep slotting and is also suitable for boring.
Taper Neck		Long taper neck features are best utilised on deep slotting and mould draft applications.

PITCH SELECTION OF PICK FEED

■ PICK FEED MILLING (CONTOURING) WITH BALL NOSE END MILLS AND END MILLS WITH CORNER RADII

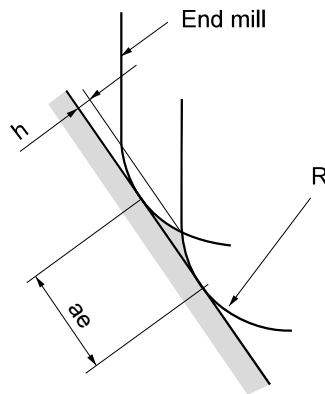

$$h = R \cdot \left[1 - \cos \left\{ \sin^{-1} \left(\frac{ae}{2R} \right) \right\} \right]$$

R : Radius of Ball Nose(RE), Corner Radius(RE)

ae : Pick Feed

h : Cusp Height

■ CORNER R OF END MILLS AND CUSP HEIGHT BY PICK FEED

Unit : mm

R \ ae	Pick Feed									
	0.1	0.2	0.3	0.4	0.5	0.6	0.7	0.8	0.9	1.0
0.5	0.003	0.010	0.023	0.042	0.067	0.100	—	—	—	—
1	0.001	0.005	0.011	0.020	0.032	0.046	0.063	0.083	0.107	—
1.5	0.001	0.003	0.008	0.013	0.021	0.030	0.041	0.054	0.069	0.086
2	0.001	0.003	0.006	0.010	0.016	0.023	0.031	0.040	0.051	0.064
2.5	0.001	0.002	0.005	0.008	0.013	0.018	0.025	0.032	0.041	0.051
3		0.002	0.004	0.007	0.010	0.015	0.020	0.027	0.034	0.042
4		0.001	0.003	0.005	0.008	0.011	0.015	0.020	0.025	0.031
5		0.001	0.002	0.004	0.006	0.009	0.012	0.016	0.020	0.025
6		0.001	0.002	0.003	0.005	0.008	0.010	0.013	0.017	0.021
8			0.001	0.003	0.004	0.006	0.008	0.010	0.013	0.016
10			0.001	0.002	0.003	0.005	0.006	0.008	0.010	0.013
12.5			0.001	0.002	0.003	0.004	0.005	0.006	0.008	0.010

R \ ae	Pick Feed									
	1.1	1.2	1.3	1.4	1.5	1.6	1.7	1.8	1.9	2.0
0.5	—	—	—	—	—	—	—	—	—	—
1	—	—	—	—	—	—	—	—	—	—
1.5	0.104	—	—	—	—	—	—	—	—	—
2	0.077	0.092	0.109	—	—	—	—	—	—	—
2.5	0.061	0.073	0.086	0.100	—	—	—	—	—	—
3	0.051	0.061	0.071	0.083	0.095	0.109	—	—	—	—
4	0.038	0.045	0.053	0.062	0.071	0.081	0.091	0.103	—	—
5	0.030	0.036	0.042	0.049	0.057	0.064	0.073	0.082	0.091	0.101
6	0.025	0.030	0.035	0.041	0.047	0.054	0.061	0.068	0.076	0.084
8	0.019	0.023	0.026	0.031	0.035	0.040	0.045	0.051	0.057	0.063
10	0.015	0.018	0.021	0.025	0.028	0.032	0.036	0.041	0.045	0.050
12.5	0.012	0.014	0.017	0.020	0.023	0.026	0.029	0.032	0.036	0.040

TECHNICAL DATA

METALLIC MATERIALS CROSS REFERENCE LIST

■ CARBON STEEL

Germany		U.K.		France	Italy	Spain	Sweden	Japan	USA	China
W-nr.	DIN	BS	EN	AFNOR	UNI	UNE	SS	JIS	AISI/SAE	GB
1.0038	RSt.37-2	4360 40 C	–	E 24-2 Ne	–	–	1311	STKM 12A STKM 12C	A570.36	15
1.0401	C15	080M15	–	CC12	C15, C16	F.111	1350	–	1015	15
1.0402	C22	050A20	2C	CC20	C20, C21	F.112	1450	–	1020	20
1.0715	9SMn28	230M07	1A	S250	CF9SMn28	F.2111 11SMn28	1912	SUM22	1213	Y15
1.0718	9SMnPb28	–	–	S250Pb	CF9SMnPb28	11SMnPb28	1914	SUM22L	12L13	–
1.0722	10SPb20	–	–	10PbF2	CF10Pb20	10SPb20	–	–	–	–
1.0736	9SMn36	240M07	1B	S300	CF9SMn36	12SMn35	–	–	1215	Y13
1.0737	9SMnPb36	–	–	S300Pb	CF9SMnPb36	12SMnP35	1926	–	12L14	–
1.1141	Ck15	080M15	32C	XC12	C16	C15K	1370	S15C	1015	15
1.1158	Ck25	–	–	–	–	–	–	S25C	1025	25
1.8900	StE380	4360 55 E	–	–	FeE390KG	–	2145	–	A572-60	–
1.0501	C35	060A35	–	CC35	C35	F.113	1550	–	1035	35
1.0503	C45	080M46	–	CC45	C45	F.114	1650	–	1045	45
1.0726	35S20	212M36	8M	35MF4	–	F210G	1957	–	1140	–
1.1157	40Mn4	150M36	15	35M5	–	–	–	–	1039	40Mn
1.1167	36Mn5	–	–	40M5	–	36Mn5	2120	SMn438(H)	1335	35Mn2
1.1170	28Mn6	150M28	14A	20M5	C28Mn	–	–	SCMn1	1330	30Mn
1.1183	Cf35	060A35	–	XC38TS	C36	–	1572	S35C	1035	35Mn
1.1191	Ck45	080M46	–	XC42	C45	C45K	1672	S45C	1045	Ck45
1.1213	Cf53	060A52	–	XC48TS	C53	–	1674	S50C	1050	50
1.0535	C55	070M55	9	–	C55	–	1655	–	1055	55
1.0601	C60	080A62	43D	CC55	C60	–	–	–	1060	60
1.1203	Ck55	070M55	–	XC55	C50	C55K	–	S55C	1055	55
1.1221	Ck60	080A62	43D	XC60	C60	–	1678	S58C	1060	60Mn
1.1274	Ck101	060A96	–	XC100	–	F.5117	1870	–	1095	–
1.1545	C105W1	BW1A	–	Y105	C36KU	F.5118	1880	SK3	W1	–
1.1545	C105W1	BW2	–	Y120	C120KU	F.515	2900	SUP4	W210	–

■ ALLOY STEEL

Germany		U.K.		France	Italy	Spain	Sweden	Japan	USA	China
W-nr.	DIN	BS	EN	AFNOR	UNI	UNE	SS	JIS	AISI/SAE	GB
1.0144	St.44.2	4360 43 C	–	E28-3	–	–	1412	SM400A, SM400B SM400C	A573-81	–
1.0570	St52-3	4360 50 B	–	E36-3	Fe52BFN Fe52CFN	–	2132	SM490A, SM490B SM490C	–	–
1.0841	St52-3	150M19	–	20MC5	Fe52	F.431	2172	–	5120	–
1.0904	55Si7	250A53	45	55S7	55Si8	56Si7	2085	–	9255	55Si2Mn
1.0961	60SiCr7	–	–	60SC7	60SiCr8	60SiCr8	–	–	9262	–
1.3505	100Cr6	534A99	31	100C6	100Cr6	F.131	2258	SUJ2	ASTM 52100	Gr15, 45G
1.5415	15Mo3	1501-240	–	15D3	16Mo3KW	16Mo3	2912	–	ASTM A204Gr.A	–
1.5423	16Mo5	1503-245-420	–	–	16Mo5	16Mo5	–	–	4520	–
1.5622	14Ni6	–	–	16N6	14Ni6	15Ni6	–	–	ASTM A350LF5	–
1.5662	X8Ni9	1501-509-510	–	–	X10Ni9	XBNI09	–	–	ASTM A353	–
1.5710	36NiCr6	640A35	111A	35NC6	–	–	–	SNC236	3135	–
1.5732	14NiCr10	–	–	14NC11	16NiCr11	15NiCr11	–	SNC415(H)	3415	–
1.5752	14NiCr14	655M13	36A	12NC15	–	–	–	SNC815(H)	3415, 3310	–
1.6523	21NiCrMo2	805M20	362	20NCD2	20NiCrMo2	20NiCrMo2	2506	SNCM220(H)	8620	–
1.6546	40NiCrMo22	311-Type 7	–	–	40NiCrMo2(KB)	40NiCrMo2	–	SNCM240	8740	–
1.6587	17CrNiMo6	820A16	–	18NCD6	–	14NiCrMo13	–	–	–	–
1.7015	15Cr3	523M15	–	12C3	–	–	–	SCr415(H)	5015	15Cr

Germany		U.K.		France	Italy	Spain	Sweden	Japan	USA	China
W-nr.	DIN	BS	EN	AFNOR	UNI	UNE	SS	JIS	AISI/SAE	GB
1.7045	42Cr4	–	–	–	–	42Cr4	2245	SCr440	5140	40Cr
1.7176	55Cr3	527A60	48	55C3	–	–	–	SUP9(A)	5155	20CrMn
1.7262	15CrMo5	–	–	12CD4	–	12CrMo4	2216	SCM415(H)	–	–
1.7335	13CrMo4 4	1501-620Gr27	–	15CD3.5 15CD4.5	14CrMo45	14CrMo45	–	–	ASTM A182 F11, F12	–
1.7380	10CrMo910	1501-622 Gr31, 45	–	12CD9 12CD10	12CrMo9 12CrMo10	TU.H	2218	–	ASTM A182 F.22	–
1.7715	14MoV63	1503-660-440	–	–	–	13MoCrV6	–	–	–	–
1.8523	39CrMoV13 9	897M39	40C	–	36CrMoV12	–	–	–	–	–
1.6511	36CrNiMo4	816M40	110	40NCD3	38NiCrMo4(KB)	35NiCrMo4	–	–	9840	–
1.6582	34CrNiMo6	817M40	24	35NCD6	35NiCrMo6(KB)	–	2541	–	4340	40CrNiMoA
1.7033	34Cr4	530A32	18B	32C4	34Cr4(KB)	35Cr4	–	SCr430(H)	5132	35Cr
1.7035	41Cr4	530M40	18	42C4	41Cr4	42Cr4	–	SCr440(H)	5140	40Cr
1.7131	16MnCr5	(527M20)	–	16MC5	16MnCr5	16MnCr5	2511	–	5115	18CrMn
1.7218	25CrMo4	1717CDS110 708M20	–	25CD4	25CrMo4(KB)	55Cr3	2225	SCM420 SCM430	4130	30CrMn
1.7220	34CrMo4	708A37	19B	35CD4	35CrMo4	34CrMo4	2234	SCM432 SCCRM3	4137 4135	35CrMo
1.7223	41CrMo4	708M40	19A	42CD4TS	41CrMo4	42CrMo4	2244	SCM 440	4140 4142	40CrMoA
1.7225	42CrMo4	708M40	19A	42CD4	42CrMo4	42CrMo4	2244	SCM440(H)	4140	42CrMo 42CrMnMo
1.7361	32CrMo12	722M24	40B	30CD12	32CrMo12	F.124.A	2240	–	–	–
1.8159	50CrV4	735A50	47	50CV4	50CrV4	51CrV4	2230	SUP10	6150	50CrVA
1.8509	41CrAlMo7	905M39	41B	40CAD6 40CAD2	41CrAlMo7	41CrAlMo7	2940	–	–	–
1.2067	100Cr6	BL3	–	Y100C6	–	100Cr6	–	–	L3	CrV, 9SiCr
1.2419	105WCr6	–	–	105WC13	100WCr6 107WCr5KU	105WCr5	2140	SKS31 SKS2, SKS3	–	CrWMo
1.2713	55NiCrMoV6	BH224/5	–	55NCDV7	–	F.520.S	–	SKT4	L6	5CrNiMo
1.5662	X8Ni9	1501-509	–	–	X10Ni9	XBNi09	–	–	ASTM A353	–
1.5680	12Ni19	–	–	Z18N5	–	–	–	–	2515	–
1.6657	14NiCrMo134	832M13	36C	–	15NiCrMo13	14NiCrMo131	–	–	–	–
1.2080	X210Cr12	BD3	–	Z200C12	X210Cr13KU X250Cr12KU	X210Cr12	–	SKD1	D3 ASTM D3	Cr12
1.2601	X153CrMoV12	BD2	–	–	X160CrMoV12	–	–	SKD11	D2	Cr12MoV
1.2363	X100CrMoV5	BA2	–	Z100CDV5	X100CrMoV5	F.5227	2260	SKD12	A2	Cr5Mo1V
1.2344	X40CrMoV51 X40CrMoV51	BH13	–	Z40CDV5	X35CrMoV05KU X40CrMoV51KU	X40CrMoV5	2242	SKD61	H13 ASTM H13	40CrMoV5
1.2436	X210CrW12	–	–	–	X215CrW121KU	X210CrW12	2312	SKD2	–	–
1.2542	45WCrV7	BS1	–	–	45WCrV8KU	45WCrSi8	2710	–	S1	–
1.2581	X30WCrV93	BH21	–	Z30WCV9	X28W09KU	X30WCrV9	–	SKD5	H21	30WCrV9
1.2601	X165CrMoV12	–	–	–	X165CrMoV12KU	X160CrMoV12	2310	–	–	–
1.2833	100V1	BW2	–	Y1105V	–	–	–	SKS43	W210	V
1.3255	S 18-1-2-5	BT4	–	Z80WKCV	X78WCo1805KU	HS18-1-1-5	–	SKH3	T4	W18Cr4VCo5
1.3355	S 18-0-1	BT1	–	Z80WCV	X75W18KU	HS18-0-1	–	SKH2	T1	–
1.3401	G-X120Mn12	Z120M12	–	Z120M12	XG120Mn12	X120MN12	–	SCMnH/1	–	–
1.4718	X45CrSi93	401S45	52	Z45CS9	X45CrSi8	F.322	–	SUH1	HW3	X45CrSi93
1.3343	S6-5-2	4959BA2	–	Z40CSD10	15NiCrMo13	–	2715	SUH3	D3	–
1.3343	S6/5/2	BM2	–	Z85WDCV	HS6-5-2-2	F.5603	2722	SKH9, SKH51	M2	–
1.3348	S 2-9-2	–	–	–	HS2-9-2	HS2-9-2	2782	–	M7	–
1.3243	S6/5/2/5	BM35	–	6-5-2-5	HS6-5-2-5	F.5613	2723	SKH55	M35	–

TECHNICAL DATA

METALLIC MATERIALS CROSS REFERENCE LIST

■ STAINLESS STEEL (FERRITIC, MARTENSITIC)

Germany		U.K.		France	Italy	Spain	Sweden	Japan	USA	China
W-nr.	DIN	BS	EN	AFNOR	UNI	UNE	SS	JIS	AISI/SAE	GB
1.4000	X7Cr13	403S17	–	Z6C13	X6Cr13	F.3110	2301	SUS403	403	0Cr13 1Cr12
1.4001	X7Cr14	–	–	–	–	F.8401	–	–	–	–
1.4005	X12CrS13	416S21	–	Z11CF13	X12CrS13	F.3411	2380	SUS416	416	–
1.4006	X10Cr13	410S21	56A	Z10C14	X12Cr13	F.3401	2302	SUS410	410	1Cr13
1.4016	X8Cr17	430S15	60	Z8C17	X8Cr17	F.3113	2320	SUS430	430	1Cr17
1.4027	G-X20Cr14	420C29	56B	Z20C13M	–	–	–	SCS2	–	–
1.4034	X46Cr13	420S45	56D	Z40CM Z38C13M	X40Cr14	F.3405	2304	SUS420J2	–	4Cr13
1.4003	–	405S17	–	Z8CA12	X6CrAl13	–	–	–	405	–
1.4021	–	420S37	–	Z8CA12	X20Cr13	–	2303	–	420	–
1.4057	X22CrNi17	431S29	57	Z15CNi6.02	X16CrNi16	F.3427	2321	SUS431	431	1Cr17Ni2
1.4104	X12CrMoS17	–	–	Z10CF17	X10CrS17	F.3117	2383	SUS430F	430F	Y1Cr17
1.4113	X6CrMo17	434S17	–	Z8CD17.01	X8CrMo17	–	2325	SUS434	434	1Cr17Mo
1.4313	X5CrNi134	425C11	–	Z4CND13.4M	(G)X6CrNi304	–	2385	SCS5	CA6-NM	–
1.4724	X10CrA113	403S17	–	Z10C13	X10CrA112	F.311	–	SUS405	405	0Cr13Al
1.4742	X10CrA118	430S15	60	Z10CAS18	X8Cr17	F.3113	–	SUS430	430	Cr17
1.4747	X80CrNiSi20	443S65	59	Z80CSN20.02	X80CrSiNi20	F.320B	–	SUH4	HNV6	–
1.4762	X10CrA124	–	–	Z10CAS24	X16Cr26	–	2322	SUH446	446	2Cr25N
1.4871	X53CrMnNiN219	349S54	–	Z52CMN21.09	X53CrMnNiN219	–	–	SUH35	EV8	5Cr2Mn9Ni4N
1.4521	X1CrMoTi182	–	–	–	–	–	2326	–	S44400	–
1.4922	X20CrMoV12-1	–	–	–	X20CrMoNi1201	–	2317	–	–	–
1.4542	–	–	–	Z7CNU17-04	–	–	–	–	630	–

■ STAINLESS STEEL (AUSTENITIC)

Germany		U.K.		France	Italy	Spain	Sweden	Japan	USA	China
W-nr.	DIN	BS	EN	AFNOR	UNI	UNE	SS	JIS	AISI/SAE	GB
1.4306	X2CrNi1911	304S11	–	Z2CN18.10	X2CrNi18.11	–	2352	SUS304L	304L	0Cr19Ni10
1.4350	X5CrNi189	304S11	58E	Z6CN18.09	X5CrNi1810	F.3551 F.3541 F.3504	2332	SUS304	304	0Cr18Ni9
1.4305	X12CrNiS188	303S21	58M	Z10CNF18.09	X10CrNiS18.09	F.3508	2346	SUS303	303	1Cr18Ni9MoZr
–	–	304C12	–	Z3CN19.10	–	–	2333	SUS304L	–	–
1.4306	X2CrNi189	304S12	–	Z2CrNi1810	X2CrNi18.11	F.3503	2352	SCS19	304L	–
1.4310	X12CrNi177	–	–	Z12CN17.07	X12CrNi1707	F.3517	2331	SUS301	301	Cr17Ni7
1.4311	X2CrNiN1810	304S62	–	Z2CN18.10	–	–	2371	SUS304LN	304LN	–
1.4401	X5CrNiMo1810	316S16	58J	Z6CND17.11	X5CrNiMo1712	F.3543	2347	SUS316	316	0Cr17Ni11Mo2
1.4308	G-X6CrNi189	304C15	–	Z6CN18.10M	–	–	–	SCS13	–	–
1.4408	G-X6CrNiMo1810	316C16	–	–	–	F.8414	–	SCS14	–	–
1.4581	G-X5CrNiMoNb1810	318C17	–	Z4CNDNb1812M	XG8CrNiMo1811	–	–	SCS22	–	–
1.4429	X2CrNiMoN1813	–	–	Z2CND17.13	–	–	2375	SUS316LN	316LN	0Cr17Ni13Mo
1.4404	–	316S13	–	Z2CND17.12	X2CrNiMo1712	–	2348	–	316L	–
1.4435	X2CrNiMo1812	316S13	–	Z2CND17.12	X2CrNiMo1712	–	2353	SCS16 SUS316L	316L	0Cr27Ni12Mo3
1.4436	–	316S13	–	Z6CND18-12-03	X8CrNiMo1713	–	2343, 2347	–	316	–
1.4438	X2CrNiMo1816	317S12	–	Z2CND19.15	X2CrNiMo1816	–	2367	SUS317L	317L	00Cr19Ni13Mo
1.4539	X1NiCrMo	–	–	Z6CNT18.10	–	–	2562	–	UNS V 0890A	–
1.4541	X10CrNiTi189	321S12	58B	Z6CNT18.10	X6CrNiTi1811	F.3553 F.3523	2337	SUS321	321	1Cr18Ni9Ti
1.4550	X10CrNiNb189	347S17	58F	Z6CNNb18.10	X6CrNiNb1811	F.3552 F.3524	2338	SUS347	347	1Cr18Ni11Nb
1.4571	X10CrNiMoTi1810	320S17	58J	Z6CNDT17.12	X6CrNiMoTi1712	F.3535	2350	–	316Ti	Cr18Ni12Mo2T
1.4583	X10CrNiMoNb1812	–	–	Z6CNDNb1713B	X6CrNiMoNb1713	–	–	–	318	Cr17Ni12Mo3Mb

P

TECHNICAL DATA

Germany		U.K.		France	Italy	Spain	Sweden	Japan	USA	China
W-nr.	DIN	BS	EN	AFNOR	UNI	UNE	SS	JIS	AISI/SAE	GB
1.4828	X15CrNiSi2012	309S24	–	Z15CNS20.12	X6CrNi2520	–	–	SUH309	309	1Cr23Ni13
1.4845	X12CrNi2521	310S24	–	Z12CN2520	X6CrNi2520	F.331	2361	SUH310	310S	OCr25Ni20
1.4406	X10CrNi18.08	–	58C	Z1NCDU25.20	–	F.8414	2370	SCS17	308	–
1.4418	X4CrNiMo165	–	–	Z6CND16-04-01	–	–	–	–	–	–
1.4568	–	316S111	–	Z8CNA17-07	X2CrNiMo1712	–	–	–	17-7PH	–
1.4504	–	–	–	–	–	–	–	–	–	–
1.4563	–	–	–	Z1NCDU31-27-03 Z1CNDU20-18-06AZ	–	–	2584 2378	–	NO8028 S31254	–
1.4878	X12CrNiTi189	321S32	58B, 58C	Z6CNT18.12B	X6CrNiTi18.11	F.3523	–	SUS321	321	1Cr18Ni9Ti

HEAT RESISTANT STEELS

Germany		U.K.		France	Italy	Spain	Sweden	Japan	USA	China
W-nr.	DIN	BS	EN	AFNOR	UNI	UNE	SS	JIS	AISI/SAE	GB
1.4864	X12NiCrSi3616	–	–	Z12NCS35.16	–	–	–	SUH330	330	–
1.4865	G-X40NiCrSi3818	330C11	–	–	XG50NiCr3919	–	–	SCH15	HT, HT 50	–

GRAY CAST IRON

Germany		U.K.		France	Italy	Spain	Sweden	Japan	USA	China
W-nr.	DIN	BS	EN	AFNOR	UNI	UNE	SS	JIS	AISI/SAE	GB
–	–	–	–	–	–	–	0100	–	–	–
–	GG 10	–	–	Ft 10 D	–	–	0110	FC100	No 20 B	–
0.6015	GG 15	Grade 150	–	Ft 15 D	G15	FG15	0115	FC150	No 25 B	HT150
0.6020	GG 20	Grade 220	–	Ft 20 D	G20	–	0120	FC200	No 30 B	HT200
0.6025	GG 25	Grade 260	–	Ft 25 D	G25	FG25	0125	FC250	No 35 B	HT250
–	–	–	–	–	–	–	–	–	No 40 B	–
0.6030	GG 30	Grade 300	–	Ft 30 D	G30	FG30	0130	FC300	No 45 B	HT300
0.6035	GG 35	Grade 350	–	Ft 35 D	G35	FG35	0135	FC350	No 50 B	HT350
0.6040	GG 40	Grade 400	–	Ft 40 D	–	–	0140	–	No 55 B	HT400
0.6660	GGL NiCr202	L-NiCuCr202	–	L-NC 202	–	–	0523	–	A436 Type 2	–

DUCTILE CAST IRON

Germany		U.K.		France	Italy	Spain	Sweden	Japan	USA	China
W-nr.	DIN	BS	EN	AFNOR	UNI	UNE	SS	JIS	AISI/SAE	GB
0.7040	GGG 40	SNG 420/12	–	FCS 400-12	GS 370-17	FGE 38-17	07 17-02	FCD400	60-40-18	QT400-18
–	GGG 40.3	SNG 370/17	–	FGS 370-17	–	–	07 17-12	–	–	–
0.7033	GGG 35.3	–	–	–	–	–	07 17-15	–	–	–
0.7050	GGG 50	SNG 500/7	–	FGS 500-7	GS 500	FGE 50-7	07 27-02	FCD500	80-55-06	QT500-7
0.7660	GGG NiCr202	Grade S6	–	S-NC202	–	–	07 76	–	A43D2	–
–	GGG NiMn137	L-NiMn 137	–	L-MN 137	–	–	07 72	–	–	–
–	GGG 60	SNG 600/3	–	FGS 600-3	–	–	07 32-03	FCD600	–	QT600-3
0.7070	GGG 70	SNG 700/2	–	FGS 700-2	GS 700-2	FGS 70-2	07 37-01	FCD700	100-70-03	QT700-18

MALLEABLE CAST IRON

Germany		U.K.		France	Italy	Spain	Sweden	Japan	USA	China
W-nr.	DIN	BS	EN	AFNOR	UNI	UNE	SS	JIS	AISI/SAE	GB
–	–	8 290/6	–	MN 32-8	–	–	08 14	FCMB310	–	–
–	GTS-35	B 340/12	–	MN 35-10	–	–	08 15	FCMW330	32510	–
0.8145	GTS-45	P 440/7	–	Mn 450	GMN45	–	08 52	FCMW370	40010	–
0.8155	GTS-55	P 510/4	–	MP 50-5	GMN55	–	08 54	FCMP490	50005	–
–	GTS-65	P 570/3	–	MP 60-3	–	–	08 58	FCMP540	70003	–
0.8165	GTS-65-02	P 570/3	–	Mn 650-3	GMN 65	–	08 56	FCMP590	A220-70003	–
–	GTS-70-02	P 690/2	–	Mn 700-2	GMN 70	–	08 62	FCMP690	A220-80002	–

SURFACE ROUGHNESS

SURFACE ROUGHNESS

(From JIS B 0601-1994)

TECHNICAL DATA

Type	Code	Determination	Determination Example (Figure)
Arithmetical Mean Roughness	Ra	<p>Ra means the value obtained by the following formula and expressed in micrometer (μm) when sampling only the reference length from the roughness curve in the direction of the mean line, taking X-axis in the direction of mean line and Y-axis in the direction of longitudinal magnification of this sampled part and the roughness curve is expressed by $y=f(x)$:</p> $Ra = \frac{1}{l} \int_0^l f(x) dx$	
Maximum Height	Rz	<p>Rz shall be that only when the reference length is sampled from the roughness curve in the direction of the mean line, the distance between the top profile peak line and the bottom profile valley line on this sampled portion is measured in the longitudinal magnification direction of roughness curve and the obtained value is expressed in micrometer (μm). Note) When finding Rz, a portion without an exceptionally high peak or low valley, which may be regarded as a flaw, is selected as the sampling length. $Rz = R_p + R_v$</p>	
Ten-Point Mean Roughness	RzJIS	<p>RzJIS shall be that only when the reference length is sampled from the roughness curve in the direction of its mean line, the sum of the average value of absolute values of the heights of five highest profile peaks (Y_p) and the depths of five deepest profile valleys (Y_v) measured in the vertical magnification direction from the mean line of this sampled portion and this sum is expressed in micrometer (μm).</p> $Rz_{JIS} = \frac{(Y_{p1} + Y_{p2} + Y_{p3} + Y_{p4} + Y_{p5}) + (Y_{v1} + Y_{v2} + Y_{v3} + Y_{v4} + Y_{v5})}{5}$	<p>$Y_{p1}, Y_{p2}, Y_{p3}, Y_{p4}, Y_{p5}$: altitudes of the five highest profile peaks of the sampled portion corresponding to the reference length l. $Y_{v1}, Y_{v2}, Y_{v3}, Y_{v4}, Y_{v5}$: altitudes of the five deepest profile valleys of the sampled portion corresponding to the reference length l.</p>

RELATIONSHIP BETWEEN ARITHMETICAL MEAN (Ra) AND CONVENTIONAL DESIGNATION (REFERENCE DATA)

Arithmetical Mean Roughness Ra		Max. Height Rz	Ten-Point Mean Roughness RzJIS	Sampling Length for Rz • RzJIS l (mm)	Conventional Finish Mark
Standard Series	Cutoff Value λ_c (mm)	Standard Series			
0.012 a	0.08	0.05s	0.05z	0.08	▽▽▽▽
0.025 a		0.1 s	0.1 z		
0.05 a	0.25	0.2 s	0.2 z	0.25	
0.1 a		0.4 s	0.4 z		
0.2 a		0.8 s	0.8 z		
0.4 a	0.8	1.6 s	1.6 z	0.8	▽▽▽
0.8 a		3.2 s	3.2 z		
1.6 a		6.3 s	6.3 z		
3.2 a		12.5 s	12.5 z		
6.3 a	2.5	25 s	25 z	2.5	▽▽
12.5 a		50 s	50 z		
25 a	8	100 s	100 z	8	▽
50 a		200 s	200 z		
100 a		400 s	400 z		

*The correlation among the three is shown for convenience and is not exact.

*Ra: The evaluation length of Rz and RzJIS is the cutoff value and sampling length multiplied by 5, respectively.

HARDNESS COMPARISON TABLE

HARDNESS CONVERSION NUMBERS OF STEEL

Brinell Hardness (HB), 10mm Ball, Load: 3000kgf		Vickers Hardness	Rockwell Hardness				Shore Hardness	Tensile Strength (Approx.) MPa	Brinell Hardness (HB), 10mm Ball, Load: 3000kgf		Vickers Hardness	Rockwell Hardness				Shore Hardness	Tensile Strength (Approx.) MPa
Standard Ball	Tungsten Carbide Ball		A Scale, Load: 60kgf, Diamond Point	B Scale, Load: 100kgf, 1/16" Ball	C Scale, Load: 150kgf, Diamond Point	D Scale, Load: 100kgf, Diamond Point			Standard Ball	Tungsten Carbide Ball		A Scale, Load: 60kgf, Diamond Point	B Scale, Load: 100kgf, 1/16" Ball	C Scale, Load: 150kgf, Diamond Point	D Scale, Load: 100kgf, Diamond Point		
		(HV)	(HRA)	(HRB)	(HRC)	(HRD)	(HS)			(HV)	(HRA)	(HRB)	(HRC)	(HRD)	(HS)		
—	—	940	85.6	—	68.0	76.9	97	—	429	429	455	73.4	—	45.7	59.7	61	1510
—	—	920	85.3	—	67.5	76.5	96	—	415	415	440	72.8	—	44.5	58.8	59	1460
—	—	900	85.0	—	67.0	76.1	95	—	401	401	425	72.0	—	43.1	57.8	58	1390
—	(767)	880	84.7	—	66.4	75.7	93	—	388	388	410	71.4	—	41.8	56.8	56	1330
—	(757)	860	84.4	—	65.9	75.3	92	—	375	375	396	70.6	—	40.4	55.7	54	1270
—	(745)	840	84.1	—	65.3	74.8	91	—	363	363	383	70.0	—	39.1	54.6	52	1220
—	(733)	820	83.8	—	64.7	74.3	90	—	352	352	372	69.3	(110.0)	37.9	53.8	51	1180
—	(722)	800	83.4	—	64.0	73.8	88	—	341	341	360	68.7	(109.0)	36.6	52.8	50	1130
—	(712)	—	—	—	—	—	—	—	331	331	350	68.1	(108.5)	35.5	51.9	48	1095
—	(710)	780	83.0	—	63.3	73.3	87	—	321	321	339	67.5	(108.0)	34.3	51.0	47	1060
—	(698)	760	82.6	—	62.5	72.6	86	—	—	—	—	—	—	—	—	—	—
—	(684)	740	82.2	—	61.8	72.1	—	—	311	311	328	66.9	(107.5)	33.1	50.0	46	1025
—	(682)	737	82.2	—	61.7	72.0	84	—	302	302	319	66.3	(107.0)	32.1	49.3	45	1005
—	(670)	720	81.8	—	61.0	71.5	83	—	293	293	309	65.7	(106.0)	30.9	48.3	43	970
—	(656)	700	81.3	—	60.1	70.8	—	—	285	285	301	65.3	(105.5)	29.9	47.6	—	950
—	(653)	697	81.2	—	60.0	70.7	81	—	277	277	292	64.6	(104.5)	28.8	46.7	41	925
—	(647)	690	81.1	—	59.7	70.5	—	—	269	269	284	64.1	(104.0)	27.6	45.9	40	895
—	(638)	680	80.8	—	59.2	70.1	80	—	262	262	276	63.6	(103.0)	26.6	45.0	39	875
—	630	670	80.6	—	58.8	69.8	—	—	255	255	269	63.0	(102.0)	25.4	44.2	38	850
—	627	667	80.5	—	58.7	69.7	79	—	248	248	261	62.5	(101.0)	24.2	43.2	37	825
—	—	677	80.7	—	59.1	70.0	—	—	241	241	253	61.8	100	22.8	42.0	36	800
—	601	640	79.8	—	57.3	68.7	77	—	235	235	247	61.4	99.0	21.7	41.4	35	785
—	—	640	79.8	—	57.3	68.7	—	—	229	229	241	60.8	98.2	20.5	40.5	34	765
—	578	615	79.1	—	56.0	67.7	75	—	223	223	234	—	97.3	(18.8)	—	—	—
—	—	607	78.8	—	55.6	67.4	—	—	217	217	228	—	96.4	(17.5)	—	33	725
—	555	591	78.4	—	54.7	66.7	73	2055	212	212	222	—	95.5	(16.0)	—	—	705
—	—	579	78.0	—	54.0	66.1	—	2015	207	207	218	—	94.6	(15.2)	—	32	690
—	534	569	77.8	—	53.5	65.8	71	1985	201	201	212	—	93.8	(13.8)	—	31	675
—	—	533	77.1	—	52.5	65.0	—	1915	197	197	207	—	92.8	(12.7)	—	30	655
—	514	547	76.9	—	52.1	64.7	70	1890	192	192	202	—	91.9	(11.5)	—	29	640
(495)	—	539	76.7	—	51.6	64.3	—	1855	187	187	196	—	90.7	(10.0)	—	—	620
—	495	528	76.3	—	51.0	63.8	68	1820	183	183	192	—	90.0	(9.0)	—	28	615
(477)	—	516	75.9	—	50.3	63.2	—	1780	183	183	188	—	89.0	(8.0)	—	27	600
—	—	508	75.6	—	49.6	62.7	—	1740	179	179	188	—	89.0	(8.0)	—	27	600
—	477	508	75.6	—	49.6	62.7	66	1740	174	174	182	—	87.8	(6.4)	—	—	585
(461)	—	495	75.1	—	48.8	61.9	—	1680	170	170	178	—	86.8	(5.4)	—	26	570
—	—	491	74.9	—	48.5	61.7	—	1670	167	167	175	—	86.0	(4.4)	—	—	560
—	461	491	74.9	—	48.5	61.7	65	1670	143	143	150	—	80.8	—	—	23	505
444	—	474	74.3	—	47.2	61.0	—	1595	143	143	150	—	78.7	—	—	22	490
—	—	472	74.2	—	47.1	60.8	—	1585	137	137	143	—	76.4	—	—	21	460
—	444	472	74.2	—	47.1	60.8	63	1585	131	131	137	—	74.0	—	—	—	450
									126	126	132	—	72.0	—	—	20	435
									121	121	127	—	69.8	—	—	19	415
									116	116	122	—	67.6	—	—	18	400
									111	111	117	—	65.7	—	—	15	385

Note 1) The above list is the same as that of AMS Metals Hand book with tensile strength in approximate metric value and Brinell hardness over a recommended range.

Note 2) 1MPa=1N/mm²

Note 3) Figures in () are rarely used and are included for reference. This list has been taken from JIS Handbook Steel I.

P

TECHNICAL DATA

FIT TOLERANCE TABLE(HOLE)

TECHNICAL DATA

Classification of Standard Dimensions (mm)		Class of Geometrical Tolerance Zone of Holes															
>	≤	B10	C9	C10	D8	D9	D10	E7	E8	E9	F6	F7	F8	G6	G7	H6	H7
-	3	+180	+85	+100	+34	+45	+60	+24	+28	+39	+12	+16	+20	+8	+12	+6	+10
		+140	+60	+60	+20	+20	+20	+14	+14	+14	+6	+6	+6	+2	+2	0	0
3	6	+188	+100	+118	+48	+60	+78	+32	+38	+50	+18	+22	+28	+12	+16	+8	+12
		+140	+70	+70	+30	+30	+30	+20	+20	+20	+10	+10	+10	+4	+4	0	0
6	10	+208	+116	+138	+62	+76	+98	+40	+47	+61	+22	+28	+35	+14	+20	+9	+15
		+150	+80	+80	+40	+40	+40	+25	+25	+25	+13	+13	+13	+5	+5	0	0
10	14	+220	+138	+165	+77	+93	+120	+50	+59	+75	+27	+34	+43	+17	+24	+11	+18
		+150	+95	+95	+50	+50	+50	+32	+32	+32	+16	+16	+16	+6	+6	0	0
14	18	+244	+162	+194	+98	+117	+149	+61	+73	+92	+33	+41	+53	+20	+28	+13	+21
		+160	+110	+110	+65	+65	+65	+40	+40	+40	+20	+20	+20	+7	+7	0	0
18	24	+270	+182	+220	+119	+142	+180	+75	+89	+112	+41	+50	+64	+25	+34	+16	+25
		+170	+120	+120	+80	+80	+80	+50	+50	+50	+25	+25	+25	+9	+9	0	0
30	40	+280	+192	+230	+146	+174	+220	+90	+106	+134	+49	+60	+76	+29	+40	+19	+30
		+180	+130	+130	+100	+100	+100	+60	+60	+60	+30	+30	+30	+10	+10	0	0
40	50	+310	+214	+260	+208	+245	+305	+125	+148	+185	+68	+83	+106	+39	+54	+25	+40
		+190	+140	+140	+145	+145	+145	+85	+85	+85	+43	+43	+43	+14	+14	0	0
50	65	+320	+224	+270	+242	+285	+355	+146	+172	+215	+79	+96	+122	+44	+61	+29	+46
		+200	+150	+150	+170	+170	+170	+100	+100	+100	+50	+50	+50	+15	+15	0	0
65	80	+360	+257	+310	+271	+320	+400	+162	+191	+240	+88	+108	+137	+49	+69	+32	+52
		+220	+170	+170	+190	+190	+190	+110	+110	+110	+56	+56	+56	+17	+17	0	0
80	100	+380	+267	+320	+299	+350	+440	+182	+214	+265	+98	+119	+151	+54	+75	+36	+57
		+240	+180	+180	+210	+210	+210	+125	+125	+125	+62	+62	+62	+18	+18	0	0
100	120	+420	+300	+360	+327	+385	+480	+198	+232	+290	+108	+131	+165	+60	+83	+40	+63
		+260	+200	+200	+230	+230	+230	+135	+135	+135	+68	+68	+68	+20	+20	0	0
120	140	+440	+310	+370	+327	+385	+480	+198	+232	+290	+108	+131	+165	+60	+83	+40	+63
		+280	+210	+210	+230	+230	+230	+135	+135	+135	+68	+68	+68	+20	+20	0	0
140	160	+470	+330	+390	+299	+350	+440	+182	+214	+265	+98	+119	+151	+54	+75	+36	+57
		+310	+230	+230	+210	+210	+210	+125	+125	+125	+62	+62	+62	+18	+18	0	0
160	180	+525	+355	+425	+327	+385	+480	+198	+232	+290	+108	+131	+165	+60	+83	+40	+63
		+340	+240	+240	+230	+230	+230	+135	+135	+135	+68	+68	+68	+20	+20	0	0
180	200	+565	+375	+445	+242	+285	+355	+146	+172	+215	+79	+96	+122	+44	+61	+29	+46
		+380	+260	+260	+170	+170	+170	+100	+100	+100	+50	+50	+50	+15	+15	0	0
200	225	+605	+395	+465	+271	+320	+400	+162	+191	+240	+88	+108	+137	+49	+69	+32	+52
		+420	+280	+280	+190	+190	+190	+110	+110	+110	+56	+56	+56	+17	+17	0	0
225	250	+690	+430	+510	+299	+350	+440	+182	+214	+265	+98	+119	+151	+54	+75	+36	+57
		+480	+300	+300	+210	+210	+210	+125	+125	+125	+62	+62	+62	+18	+18	0	0
250	280	+750	+460	+540	+327	+385	+480	+198	+232	+290	+108	+131	+165	+60	+83	+40	+63
		+540	+330	+330	+230	+230	+230	+135	+135	+135	+68	+68	+68	+20	+20	0	0
280	315	+830	+500	+590	+327	+385	+480	+198	+232	+290	+108	+131	+165	+60	+83	+40	+63
		+600	+360	+360	+230	+230	+230	+135	+135	+135	+68	+68	+68	+20	+20	0	0
315	355	+910	+540	+630	+299	+350	+440	+182	+214	+265	+98	+119	+151	+54	+75	+36	+57
		+680	+400	+400	+210	+210	+210	+125	+125	+125	+62	+62	+62	+18	+18	0	0
355	400	+1010	+595	+690	+327	+385	+480	+198	+232	+290	+108	+131	+165	+60	+83	+40	+63
		+760	+440	+440	+230	+230	+230	+135	+135	+135	+68	+68	+68	+20	+20	0	0
400	450	+1090	+635	+730	+327	+385	+480	+198	+232	+290	+108	+131	+165	+60	+83	+40	+63
		+840	+480	+480	+230	+230	+230	+135	+135	+135	+68	+68	+68	+20	+20	0	0

Note 1) Values shown in the upper portion of the respective boxes are the upper dimensional tolerance, while values shown in the lower portion are the lower dimensional tolerance.

Class of Geometrical Tolerance Zone of Holes

H8	H9	H10	JS6	JS7	K6	K7	M6	M7	N6	N7	P6	P7	R7	S7	T7	U7	X7
+14 0	+25 0	+40 0	± 3	± 5	0 -6	0 -10	-2 -8	-2 -12	-4 -10	-4 -14	-6 -12	-6 -16	-10 -20	-14 -24	-	-18 -28	-20 -30
+18 0	+30 0	+48 0	± 4	± 6	+2 -6	+3 -9	-1 -9	0 -12	-5 -13	-4 -16	-9 -17	-8 -20	-11 -23	-15 -27	-	-19 -31	-24 -36
+22 0	+36 0	+58 0	± 4.5	± 7	+2 -7	+5 -10	-3 -12	0 -15	-7 -16	-4 -19	-12 -21	-9 -24	-13 -28	-17 -32	-	-22 -37	-28 -43
+27 0	+43 0	+70 0	± 5.5	± 9	+2 -9	+6 -12	-4 -15	0 -18	-9 -20	-5 -23	-15 -26	-11 -29	-16 -34	-21 -39	-	-26 -44	-33 -51 -56
+33 0	+52 0	+84 0	± 6.5	± 10	+2 -11	+6 -15	-4 -17	0 -21	-11 -24	-7 -28	-18 -31	-14 -35	-20 -41	-27 -48	-	-33 -54	-46 -67 -77
+39 0	+62 0	+100 0	± 8	± 12	+3 -13	+7 -18	-4 -20	0 -25	-12 -28	-8 -33	-21 -37	-17 -42	-25 -50	-34 -59	-39 -64 -70	-51 -76 -86	-
+46 0	+74 0	+120 0	± 9.5	± 15	+4 -15	+9 -21	-5 -24	0 -30	-14 -33	-9 -39	-26 -45	-21 -51	-30 -60 -62	-42 -72 -78	-55 -85 -94	-76 -106 -121	-
+54 0	+87 0	+140 0	± 11	± 17	+4 -18	+10 -25	-6 -28	0 -35	-16 -38	-10 -45	-30 -52	-24 -59	-38 -73 -81	-58 -93 -101	-78 -113 -126	-111 -146 -166	-
+63 0	+100 0	+160 0	± 12.5	± 20	+4 -21	+12 -28	-8 -33	0 -40	-20 -45	-12 -52	-36 -61	-28 -68	-48 -88 -90 -93	-77 -117 -125 -133	-107 -147 -159 -171	-	-
+72 0	+115 0	+185 0	± 14.5	± 23	+5 -24	+13 -33	-8 -37	0 -46	-22 -51	-14 -60	-41 -70	-33 -79	-60 -106 -109 -113	-113 -159 -123 -169	-	-	-
+81 0	+130 0	+210 0	± 16	± 26	+5 -27	+16 -36	-9 -41	0 -52	-25 -57	-14 -66	-47 -79	-36 -88	-74 -126 -78 -130	-	-	-	-
+89 0	+140 0	+230 0	± 18	± 28	+7 -29	+17 -40	-10 -46	0 -57	-26 -62	-16 -73	-51 -87	-41 -98	-87 -144 -93 -150	-	-	-	-
+97 0	+155 0	+250 0	± 20	± 31	+8 -32	+18 -45	-10 -50	0 -63	-27 -67	-17 -80	-55 -95	-45 -108	-103 -166 -109 -172	-	-	-	-

FIT TOLERANCE TABLE(SHAFT)

TECHNICAL DATA

Classification of Standard Dimensions (mm)		Class of Geometrical Tolerance Zone of Shafts														
>	≤	b9	c9	d8	d9	e7	e8	e9	f6	f7	f8	g5	g6	h5	h6	h7
-	3	-140	-60	-20	-20	-14	-14	-14	-6	-6	-6	-2	-2	0	0	0
		-165	-85	-34	-45	-24	-28	-39	-12	-16	-20	-6	-8	-4	-6	-10
3	6	-140	-70	-30	-30	-20	-20	-20	-10	-10	-10	-4	-4	0	0	0
		-170	-100	-48	-60	-32	-38	-50	-18	-22	-28	-9	-12	-5	-8	-12
6	10	-150	-80	-40	-40	-25	-25	-25	-13	-13	-13	-5	-5	0	0	0
		-186	-116	-62	-76	-40	-47	-61	-22	-28	-35	-11	-14	-6	-9	-15
10	14	-150	-95	-50	-50	-32	-32	-32	-16	-16	-16	-6	-6	0	0	0
		-193	-138	-77	-93	-50	-59	-75	-27	-34	-43	-14	-17	-8	-11	-18
14	18	-150	-95	-50	-50	-32	-32	-32	-16	-16	-16	-6	-6	0	0	0
		-193	-138	-77	-93	-50	-59	-75	-27	-34	-43	-14	-17	-8	-11	-18
18	24	-160	-110	-65	-65	-40	-40	-40	-20	-20	-20	-7	-7	0	0	0
		-212	-162	-98	-117	-61	-73	-92	-33	-41	-53	-16	-20	-9	-13	-21
24	30	-160	-110	-65	-65	-40	-40	-40	-20	-20	-20	-7	-7	0	0	0
		-212	-162	-98	-117	-61	-73	-92	-33	-41	-53	-16	-20	-9	-13	-21
30	40	-170	-120	-80	-80	-50	-50	-50	-25	-25	-25	-9	-9	0	0	0
		-232	-182	-119	-142	-75	-89	-112	-41	-50	-64	-20	-25	-11	-16	-25
40	50	-180	-130	-119	-142	-75	-89	-112	-41	-50	-64	-20	-25	-11	-16	-25
		-242	-192	-119	-142	-75	-89	-112	-41	-50	-64	-20	-25	-11	-16	-25
50	65	-190	-140	-100	-100	-60	-60	-60	-30	-30	-30	-10	-10	0	0	0
		-264	-214	-100	-100	-60	-60	-60	-30	-30	-30	-10	-10	0	0	0
65	80	-200	-150	-146	-174	-90	-106	-134	-49	-60	-76	-23	-29	-13	-19	-30
		-274	-224	-146	-174	-90	-106	-134	-49	-60	-76	-23	-29	-13	-19	-30
80	100	-220	-170	-120	-120	-72	-72	-72	-36	-36	-36	-12	-12	0	0	0
		-307	-257	-120	-120	-72	-72	-72	-36	-36	-36	-12	-12	0	0	0
100	120	-240	-180	-174	-207	-107	-126	-159	-58	-71	-90	-27	-34	-15	-22	-35
		-327	-267	-174	-207	-107	-126	-159	-58	-71	-90	-27	-34	-15	-22	-35
120	140	-260	-200	-145	-145	-85	-85	-85	-43	-43	-43	-14	-14	0	0	0
		-360	-300	-145	-145	-85	-85	-85	-43	-43	-43	-14	-14	0	0	0
140	160	-280	-210	-208	-245	-125	-148	-185	-68	-83	-106	-32	-39	-18	-25	-40
		-380	-310	-208	-245	-125	-148	-185	-68	-83	-106	-32	-39	-18	-25	-40
160	180	-310	-230	-208	-245	-125	-148	-185	-68	-83	-106	-32	-39	-18	-25	-40
		-410	-330	-208	-245	-125	-148	-185	-68	-83	-106	-32	-39	-18	-25	-40
180	200	-340	-240	-170	-170	-100	-100	-100	-50	-50	-50	-15	-15	0	0	0
		-455	-355	-170	-170	-100	-100	-100	-50	-50	-50	-15	-15	0	0	0
200	225	-380	-260	-242	-285	-146	-172	-215	-79	-96	-122	-35	-44	-20	-29	-46
		-495	-375	-242	-285	-146	-172	-215	-79	-96	-122	-35	-44	-20	-29	-46
225	250	-420	-280	-242	-285	-146	-172	-215	-79	-96	-122	-35	-44	-20	-29	-46
		-535	-395	-242	-285	-146	-172	-215	-79	-96	-122	-35	-44	-20	-29	-46
250	280	-480	-300	-190	-190	-110	-110	-110	-56	-56	-56	-17	-17	0	0	0
		-610	-430	-190	-190	-110	-110	-110	-56	-56	-56	-17	-17	0	0	0
280	315	-540	-330	-271	-320	-162	-191	-240	-88	-108	-137	-40	-49	-23	-32	-52
		-670	-460	-271	-320	-162	-191	-240	-88	-108	-137	-40	-49	-23	-32	-52
315	355	-600	-360	-210	-210	-125	-125	-125	-62	-62	-62	-18	-18	0	0	0
		-740	-500	-210	-210	-125	-125	-125	-62	-62	-62	-18	-18	0	0	0
355	400	-680	-400	-299	-350	-182	-214	-265	-98	-119	-151	-43	-54	-25	-36	-57
		-820	-540	-299	-350	-182	-214	-265	-98	-119	-151	-43	-54	-25	-36	-57
400	450	-760	-440	-230	-230	-135	-135	-135	-68	-68	-68	-20	-20	0	0	0
		-915	-595	-230	-230	-135	-135	-135	-68	-68	-68	-20	-20	0	0	0
450	500	-840	-480	-327	-385	-198	-232	-290	-108	-131	-165	-47	-60	-27	-40	-63
		-995	-635	-327	-385	-198	-232	-290	-108	-131	-165	-47	-60	-27	-40	-63

Note 1) Values shown in the upper portion of the respective boxes are the upper dimensional tolerance, while values shown in the lower portion are the lower dimensional tolerance.

Class of Geometrical Tolerance Zone of Shafts

h8	h9	js5	js6	js7	k5	k6	m5	m6	n6	p6	r6	s6	t6	u6	x6
0 -14	0 -25	± 2	± 3	± 5	+4 0	+6 0	+6 +2	+8 +2	+10 +4	+12 +6	+16 +10	+20 +14	—	+24 +18	+26 +20
0 -18	0 -30	± 2.5	± 4	± 6	+6 +1	+9 +1	+9 +4	+12 +4	+16 +8	+20 +12	+23 +15	+27 +19	—	+31 +23	+36 +28
0 -22	0 -36	± 3	± 4.5	± 7	+7 +1	+10 +1	+12 +6	+15 +6	+19 +10	+24 +15	+28 +19	+32 +23	—	+37 +28	+43 +34
0 -27	0 -43	± 4	± 5.5	± 9	+9 +1	+12 +1	+15 +7	+18 +7	+23 +12	+29 +18	+34 +23	+39 +28	—	+44 +33	+51 +40 +56 +45
0 -33	0 -52	± 4.5	± 6.5	± 10	+11 +2	+15 +2	+17 +8	+21 +8	+28 +15	+35 +22	+41 +28	+48 +35	—	+54 +41	+67 +54 +77 +64
0 -39	0 -62	± 5.5	± 8	± 12	+13 +2	+18 +2	+20 +9	+25 +9	+33 +17	+42 +26	+50 +34	+59 +43	+64 +48 +70 +54	+76 +60 +86 +70	—
0 -46	0 -74	± 6.5	± 9.5	± 15	+15 +2	+21 +2	+24 +11	+30 +11	+39 +20	+51 +32	+60 +41 +62 +43	+72 +53 +78 +59	+85 +66 +94 +75	+106 +87 +121 +102	—
0 -54	0 -87	± 7.5	± 11	± 17	+18 +3	+25 +3	+28 +13	+35 +13	+45 +23	+59 +37	+73 +51 +76 +54	+93 +71 +101 +79	+113 +91 +126 +104	+146 +124 +166 +144	—
0 -63	0 -100	± 9	± 12.5	± 20	+21 +3	+28 +3	+33 +15	+40 +15	+52 +27	+68 +43	+88 +63 +90 +65 +93 +68	+117 +92 +125 +100 +133 +108	+147 +122 +159 +134 +171 +146	—	—
0 -72	0 -115	± 10	± 14.5	± 23	+24 +4	+33 +4	+37 +17	+46 +17	+60 +31	+79 +50	+106 +77 +109 +80 +113 +84	+151 +122 +159 +130 +169 +140	—	—	—
0 -81	0 -130	± 11.5	± 16	± 26	+27 +4	+36 +4	+43 +20	+52 +20	+66 +34	+88 +56	+126 +94 +130 +98	—	—	—	—
0 -89	0 -140	± 12.5	± 18	± 28	+29 +4	+40 +4	+46 +21	+57 +21	+73 +37	+98 +62	+144 +108 +150 +114	—	—	—	—
0 -97	0 -155	± 13.5	± 20	± 31	+32 +5	+45 +5	+50 +23	+63 +23	+80 +40	+108 +68	+166 +126 +172 +132	—	—	—	—

INTERNATIONAL SYSTEM OF UNITS

UNIT CONVERSION TABLE FOR EASIER CHANGE INTO SI UNITS
(Bold type Indicates SI unit)

● **Pressure**

Pa	kPa	MPa	bar	kgf/cm ²	atm	mmH ₂ O	mmHg or Torr
1	1×10 ⁻³	1×10 ⁻⁶	1×10 ⁻⁵	1.01972×10 ⁻⁵	9.86923×10 ⁻⁶	1.01972×10 ⁻¹	7.50062×10 ⁻³
1×10 ³	1	1×10 ⁻³	1×10 ⁻²	1.01972×10 ⁻²	9.86923×10 ⁻³	1.01972×10 ²	7.50062
1×10 ⁶	1×10 ³	1	1×10	1.01972×10	9.86923	1.01972×10 ⁵	7.50062×10 ³
1×10 ⁵	1×10 ²	1×10 ⁻¹	1	1.01972	9.86923×10 ⁻¹	1.01972×10 ⁴	7.50062×10 ²
9.80665×10 ⁴	9.80665×10	9.80665×10 ⁻²	9.80665×10 ⁻¹	1	9.67841×10 ⁻¹	1×10 ⁴	7.35559×10 ²
1.01325×10 ⁵	1.01325×10 ²	1.01325×10 ⁻¹	1.01325	1.03323	1	1.03323×10 ⁴	7.60000×10 ²
9.80665	9.80665×10 ⁻³	9.80665×10 ⁻⁶	9.80665×10 ⁻⁵	1×10 ⁻⁴	9.67841×10 ⁻⁵	1	7.35559×10 ⁻²
1.33322×10 ²	1.33322×10 ⁻¹	1.33322×10 ⁻⁴	1.33322×10 ⁻³	1.35951×10 ⁻³	1.31579×10 ⁻³	1.35951×10	1

Note 1) 1Pa=1N/m²

● **Force**

N	dyn	kgf
1	1×10 ⁵	1.01972×10 ⁻¹
1×10 ⁻⁵	1	1.01972×10 ⁻⁶
9.80665	9.80665×10 ⁵	1

● **Stress**

Pa	MPa or N/mm ²	kgf/mm ²	kgf/cm ²
1	1×10 ⁻⁶	1.01972×10 ⁻⁷	1.01972×10 ⁻⁵
1×10 ⁶	1	1.01972×10 ⁻¹	1.01972×10
9.80665×10 ⁶	9.80665	1	1×10 ²
9.80665×10 ⁴	9.80665×10 ⁻²	1×10 ⁻²	1

Note 1) 1Pa=1N/m²

● **Work / Energy / Quantity of Heat**

J	kW·h	kgf·m	kcal
1	2.77778×10 ⁻⁷	1.01972×10 ⁻¹	2.38889×10 ⁻⁴
3.600 ×10 ⁶	1	3.67098×10 ⁵	8.6000 ×10 ²
9.80665	2.72407×10 ⁻⁶	1	2.34270×10 ⁻³
4.18605×10 ³	1.16279×10 ⁻³	4.26858×10 ²	1

Note 1) 1J=1W·s, 1J=1N·m

1cal=4.18605J

(By the law of weights and measures)

● **Power (Rate of Production / Motive Power) /Heat Flow Rate**

W	kgf·m/s	PS	kcal/h
1	1.01972×10 ⁻¹	1.35962×10 ⁻³	8.6000 ×10 ⁻¹
9.80665	1	1.33333×10 ⁻²	8.43371
7.355 ×10 ²	7.5 ×10	1	6.32529×10 ²
1.16279	1.18572×10 ⁻¹	1.58095×10 ⁻³	1

Note 1) 1W=1J/s, PS:French horse power

1PS=0.7355kW

1cal=4.18605J

(By the law of weights and measures)

INDEX

INDEX FOR TOOL NUMBER

A.....	2
C.....	2
D.....	2
I.....	2
M.....	2
V.....	3

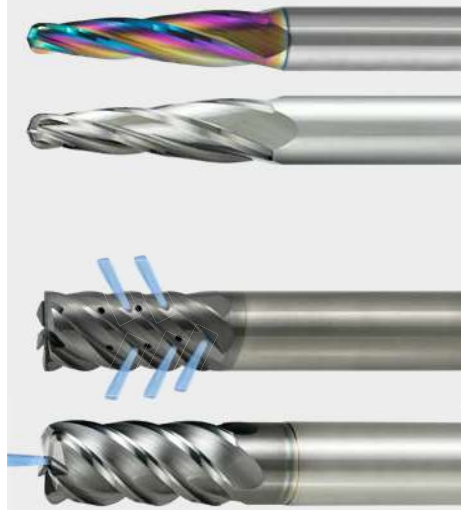

INDEX FOR TOOL NUMBER

Order Number	PRODUCT NAME	Page	Order Number	PRODUCT NAME	Page
A					
A3SA	ALIMASTER end mill	I275	iMX-C15T-C	Indexable head end mill	J056
A3SARB	ALIMASTER end mill	I276	iMX-C3A	Indexable head end mill	J053
AM2MB	ALIMASTER end mill	I258	iMX-C4FD-C	Indexable head end mill	J049
AM2MR	ALIMASTER end mill	I260	iMX-C4FV	Indexable head end mill	J051
AM2SC	ALIMASTER end mill	I259	iMX-C4HV	Indexable head end mill	J038
AM2SCR	ALIMASTER end mill	I264	iMX-C4HV-S	Indexable head end mill	J040
AM3MF	ALIMASTER end mill	I262	iMX-C6HV	Indexable head end mill	J047
AM3SS	ALIMASTER end mill	I261	iMX-C8T-C	Indexable head end mill	J056
AM3SSRB	ALIMASTER end mill	I267	iMX-CH3L	Indexable head end mill	J058
AM4MF	ALIMASTER end mill	I263	iMX-CH6V	Indexable head end mill	J060
AMMR	ALIMASTER end mill	I271	iMX-○○○○○○○○○○C	Holder (For iMX type end mill)	J062
AMSR	ALIMASTER end mill	I269	iMX-○○○○○○○○○○L○○○C	Holder (For iMX type end mill)	J062
C					
C4LATB	Uncoated carbide end mill	I273	iMX-○○○○○○○○○○L○○○S	Holder (For iMX type end mill)	J063
CE4SRB/CE6SRB	Ceramic end mill	I242	iMX-○○○○○○○○○○S	Holder (For iMX type end mill)	J063
CRN2MB	CRN end mill	I244	iMX-○○-WR	Wrench (For iMX type end mill)	J062, J063
CRN2MRB	CRN end mill	I254	iMX-R4F	Indexable head end mill	J022
CRN2MS	CRN end mill	I249	iMX-RC4F-C	Indexable head end mill	J025
CRN2XL	CRN end mill	I252	iMX-S3A	Indexable head end mill	J019
CRN2XLB	CRN end mill	I246	iMX-S3HV	Indexable head end mill	J008
CRN2XLRB	CRN end mill	I256	iMX-S4HV	Indexable head end mill	J012
CRN4JC	CRN end mill	I251	iMX-S4HV-S	Indexable head end mill	J013
D			M		
DC2SB	Diamond(DC) coated end mill	I291	MP2ES	MS Plus end mill	I108
DC2XLB	Diamond(DC) coated end mill	I293	MP3ES	MS Plus end mill	I111
DF2XLB	Diamond(DF) coated end mill	I285	MP4EC	MS Plus end mill	I114
DF2XLBF	Diamond(DF) coated end mill	I288	MP2MB	MS Plus end mill	I081
DF4JC	Diamond(DF) coated end mill	I290	MP2SB	MS Plus end mill	I080
DFC4JC	Diamond(DFC) coated end mill	I283	MP2SDB	MS Plus end mill	I083
DFCJRT	Diamond(DFC) coated end mill	I284	MP2SSB	MS Plus end mill	I079
DLC4LATB	DLC coated end mill	I278	MP2XLB	MS Plus end mill	I085
DLC3SA	DLC coated end mill	I280	MP3XB	MS Plus end mill	I093
DLC3SARB	DLC coated end mill	I281	MPJHV	MS Plus end mill	I106
I					
iMX-B2S	Indexable head end mill	J027	MPMHV	MS Plus end mill	I103
iMX-B3FV	Indexable head end mill	J029	MPMHV/W	MS Plus end mill	I101
iMX-B4HV	Indexable head end mill	J031	MPMHVRB	MS Plus end mill	I117
iMX-B4HV-E	Indexable head end mill	J032	MPSHV/W	MS Plus end mill	I099
iMX-B4S	Indexable head end mill	J028	MPXLRB	MS Plus end mill	I120
iMX-B4WH-S	Indexable head end mill	J036	MS2ES	MSTAR end mill	I055
iMX-B6HV	Indexable head end mill	J034	MS2JS	MSTAR end mill	I040
iMX-C10HV	Indexable head end mill	J047	MS2LS	MSTAR end mill	I042
iMX-C10T-C	Indexable head end mill	J056	MS2MRB	MSTAR end mill	I071
iMX-C12HV	Indexable head end mill	J047	MS2MS	MSTAR end mill	I037
iMX-C12T-C	Indexable head end mill	J056	MS2SS	MSTAR end mill	I036
			MS2XL	MSTAR end mill	I060
			MS2XL6	MSTAR end mill	I064
			MS3ES	MSTAR end mill	I056
			MS4EC	MSTAR end mill	I058
			MS4JC	MSTAR end mill	I049
			MS4MC	MSTAR end mill	I047

Order Number	PRODUCT NAME	Page	Order Number	PRODUCT NAME	Page
MS4MRB	.MSTAR end mill	1074	VQHVRB	.VQ end mill	1228
MS4SC	.MSTAR end mill	1046	VQJHV	.VQ end mill	1214
MS4XL	.MSTAR end mill	1067	VQMHV	.VQ end mill	1210
MS6MH-E/MS8MH-E	.MSTAR end mill	1077	VQMHRB	.VQ end mill	1221
MSMHD	.MSTAR end mill	1052	VQMHRBF	.VQ end mill	1226
MSMHZD	.MSTAR end mill	1044	VQMHZV	.VQ end mill	1201
MSSHD	.MSTAR end mill	1051	VQMHZVOH	.VQ end mill	1207
V			VQN2MB	.VQ end mill	1191
VA2MS	.VIOLET end mill	1296	VQN4MB	.VQ end mill	1192
VA2SS	.VIOLET end mill	1295	VQN4MBF	.VQ end mill	1193
VA4MC	.VIOLET end mill	1298	VQSVR	.VQ end mill	1239
VAMFPR	.VIOLET end mill	1302	VQT5MVRB	.VQ end mill	1232
VAMR	.VIOLET end mill	1304	VQT6UR	.VQ end mill	1236
VASFPR	.VIOLET end mill	1300	VQXL	.VQ end mill	1216
VF2MV	.IMPACT MIRACLE end mill	1140			
VF2WB	.IMPACT MIRACLE end mill	1176			
VF2XL	.IMPACT MIRACLE end mill	1143			
VF2XLB	.IMPACT MIRACLE end mill	1129			
VF2XLBS	.IMPACT MIRACLE end mill	1127			
VF3XB	.IMPACT MIRACLE end mill	1135			
VF4MB	.IMPACT MIRACLE end mill	1125			
VF4MV	.IMPACT MIRACLE end mill	1142			
VF6MHV	.IMPACT MIRACLE end mill	1177			
VF6MHVRB	.IMPACT MIRACLE end mill	1180			
VF6SVRCH	.IMPACT MIRACLE end mill	1190			
VF8MHVCH	.IMPACT MIRACLE end mill	1179			
VF8MHVRBCH	.IMPACT MIRACLE end mill	1184			
VFFDRB	.IMPACT MIRACLE end mill	1148			
VFHVRB	.IMPACT MIRACLE end mill	1153, 1159			
VFMD	.IMPACT MIRACLE end mill	1146			
VFMDRB	.IMPACT MIRACLE end mill	1151			
VFMFPR	.IMPACT MIRACLE end mill	1188			
VFMHVCH	.IMPACT MIRACLE end mill	1178			
VFMHVRBCH	.IMPACT MIRACLE end mill	1182			
VFR2SB	.IMPACT MIRACLE REVOLUTION end mill	1164			
VFR2SBF	.IMPACT MIRACLE REVOLUTION end mill	1166			
VFR2SSB	.IMPACT MIRACLE REVOLUTION end mill	1163			
VFR2XLB	.IMPACT MIRACLE REVOLUTION end mill	1168			
VFRSRB	.IMPACT MIRACLE REVOLUTION end mill	1171			
VFSD	.IMPACT MIRACLE end mill	1145			
VFSDRB	.IMPACT MIRACLE end mill	1150			
VFSFPR	.IMPACT MIRACLE end mill	1186			
VFSFPRCH	.IMPACT MIRACLE end mill	1189			
VQ2XLB	.VQ end mill	1199			
VQ4SVB	.VQ end mill	1194			
VQ4WB	.VQ end mill	1196			
VQ6MHVCH	.VQ end mill	1219			
VQ6MHVRBCH	.VQ end mill	1230			
VQFDRB	.VQ end mill	1234			

WORLDWIDE



MITSUBISHI MATERIALS CORPORATION - METALWORKING SOLUTIONS COMPANY A SYNERGY FOR SUCCESS

The Metalworking Solutions division of Mitsubishi Materials is dedicated to the development and processing of metals, cutting materials, coatings and precision tools. Profound know-how and many years of experience in manufacturing technology makes Mitsubishi Materials one of the leading suppliers in the precision cutting tool market.

The company's global market presence, with headquarters and sales offices in Japan, Europe, India, Brazil, China, Thailand, Mexico and the US, as well as a broad network of international distributors, ensures a targeted, comprehensive service.

Information exchange and technology transfer, open communication and growing synergies guarantee maximum performance and sustainable customer success.

METALWORKING SOLUTIONS COMPANY





MITSUBISHI MATERIALS CORPORATION

GERMANY

MMC HARTMETALL GMBH
Comeniusstr. 2 . 40670 Meerbusch
Phone +49 2159 91890 . Fax +49 2159 918966
Email admin@mmchg.de

U.K.

MMC HARDMETAL U.K. LTD.
Mitsubishi House . Galena Close . Tamworth . Staffs. B77 4AS
Phone +44 1827 312312 . Fax +44 1827 312314
Email sales@mitsubishicarbide.co.uk

SPAIN

MITSUBISHI MATERIALS ESPAÑA, S.A.
Calle Emperador 2 . 46136 Museros/Valencia
Phone +34 96 1441711 . Fax +34 96 1443786
Email comercial@mmevalencia.es

FRANCE

MMC METAL FRANCE S.A.R.L.
6, Rue Jacques Monod . 91400 Orsay
Phone +33 1 69 35 53 53 . Fax +33 1 69 35 53 50
Email mmfsales@mmc-metal-france.fr

POLAND

MMC HARDMETAL POLAND SP. Z O.O
Al. Armii Krajowej 61 . 50 - 541 Wrocław
Phone +48 71335 1620 . Fax +48 71335 1621
Email sales@mitsubishicarbide.com.pl

RUSSIA

MMC HARDMETAL OOO LTD.
Electrozavodskaya St. 24 . build. 3 . Moscow . 107023
Phone +7 495 725 58 85 . Fax +7 495 981 39 79
Email info@mmc-carbide.ru

ITALY

MMC ITALIA S.R.L.
Viale Certosa 144 . 20156 Milano
Phone +39 0293 77031 . Fax +39 0293 589093
Email info@mmc-italia.it

TURKEY

MMC HARTMETALL GMBH ALMANYA - İZMİR MERKEZ ŞUBESİ
Adalet Mahallesi Anadolu Caddesi No: 41-1 . 15001 35530 Bayraklı/İzmir
Phone +90 232 5015000 . Fax +90 232 5015007
Email info@mmchg.com.tr

www.mitsubishicarbide.com | www.mmc-hardmetal.com

C009E

Published: 2022.04 (6.0 DP), Printed in Germany